

Declaration of Conformity

We, Manufacturer/Importer

(full address)

G.B.T. Technology Trading GmbH

Ausschlagstr. Weg 4, 42699 Solingen, Germany

(description of the apparatus, system, installation to which it refers)

declare that the product

VGA Card

GV-N52128DS

(reference to the specification under which conformity is declared)
is in conformity with
in accordance with 90/269 EEC-EMC Directive

EN 55011

Limits and methods of measurement of radio disturbance characteristics of industrial, scientific and medical (ISM) high frequency equipment

EN 61000-3-2
 EN 61000-3-3

Disturbances in supply systems caused by household appliances and similar electrical equipment "Voltage fluctuations"

EN 55013

Limits and methods of measurement of radio disturbance characteristics of equipment

EN 55024

Information Technology equipment/Immunity measurement

EN 55014-1

Limits and methods of measurement of radio disturbance characteristics of household electrical appliances, portable tools and similar electrical apparatus

EN 50082-1

Generic immunity standard Part 1: Residential, commercial and light industry industrial environment

EN 55015

Limits and methods of measurement of radio disturbance characteristics of television sets and luminaires

EN 55014-2

Immunity requirements for household appliances tools and similar apparatus

EN 55020

Immunity from radio interference of equipment

EN 50091-2

EMC requirements for uninterruptible power systems (UPS)

EN 55022

Limits and methods of measurement of radio disturbance characteristics of information technology equipment

EN 50091-1

Immunity requirements for household appliances tools and similar apparatus

DIN VDE 0885
 Part 1
 Part 2

Cabled distribution systems; Equipment for power supply systems; Immunity from sound and television signals

CE marking



(EC conformity marking)

The manufacturer also declares the conformity of above mentioned product with the safety requirements in accordance with LVD 702/95 EEC

EN 60065

Safety requirements for mains operated household and similar general use

EN 60950

Safety for information technology equipment including electrical business equipment

EN 60335

Safety of household and similar electrical appliances

EN 50091-1

General and Safety requirements for uninterruptible power systems (UPS)

Manufacturer/Importer

Signature: Jimmy Huang

(Stamp)

Date Feb. 4, 2005

Name: Timmy Huang

DECLARATION OF CONFORMITY

Per FCC Part 2 Section 2.1077(a)



Responsible Party Name: G.B.T. INC. (U.S.A.)

Address: 17358 Railroad Street

City of Industry, CA 91748

Phone/Fax No: (818) 854-9338 / (818) 854-9339

hereby declares that the product

Product Name: **VGA Card**

Model Number: **GV-N52128DS**

Conforms to the following specifications:

FCC Part 15, Subpart B, Section 15.107(a) and Section 15.109

(a), Class B Digital Device

Supplementary Information:

This device complies with part 15 of the FCC Rules. Operation is subject to the following two conditions: (1) This device may not cause harmful and (2) this device must accept any interference received, including that may cause undesired operation.

Representative Person's Name: ERIC LU

Signature: Eric Lu

Date: Feb. 4, 2005

Minimum System Requirement

- IBM® or 100% PC compatible with Pentium® III 650MHz or AMD Athlon 650MHz class processor or higher
- One available AGP3.0 compliant slot or better
- Operating Systems Win® 98/98SE / Win® 2000 / Win® ME / Win® XP
- 64MB system memory
- 50MB of available disk space for full installation
- CD-ROM or DVD-ROM drive

Table of Contents

1. Introduction	2
1.1. Features	2
1.2. Board Layout	2
2. Hardware Installation	3
3. Software Installation	4
3.1. DirectX Installation	4
3.2. Driver Installation (Windows® XP/2000/ME/98)	4
3.3. V-Tuner Installation	5
4. Appendix	6
4.1. BIOS Flash Utility	6
4.2. How to Reflash BIOS in MS-DOS mode	6
4.3. Resolutions and Color Depth Table (In Windows® XP)	6

1. Introduction

1.1. Features

- Powered by NVIDIA GeForce FX 5200 Graphics Processing Unit (GPU)
- Supports Direct X 9.0
- Supports AGP 8X
- Integrated with 128MB DDR memory
- Supports TV-Out and D-Sub connectors
- Supports DVI-D connector

1.2. Board Layout

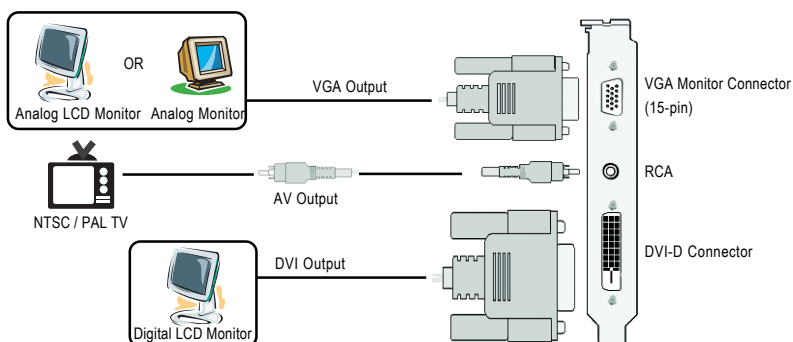
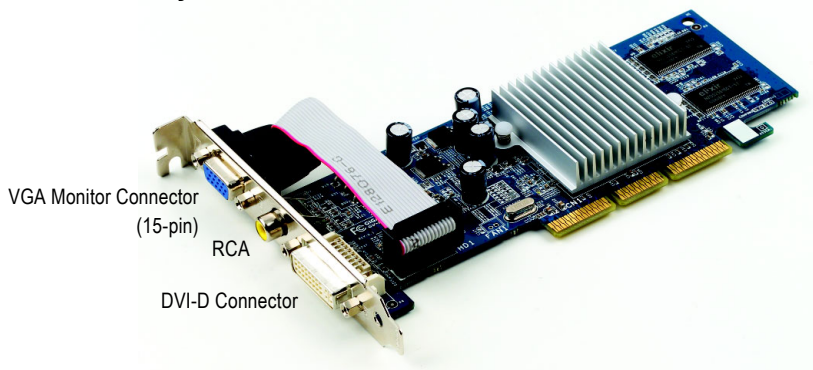

2. Hardware Installation

Installing your graphics card.

Now that you have prepared your computer, you are ready to install your graphics card.

1. Locate the AGP slot. If necessary, remove the metal cover from this slot; then align your graphics card with the AGP slot, and press it in firmly until the card is fully seated.

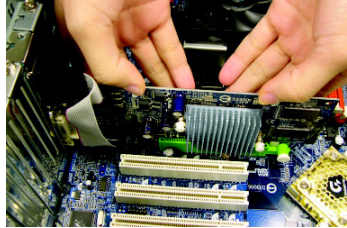

2. Replace the screw to fasten the card in place, and replace the computer cover.

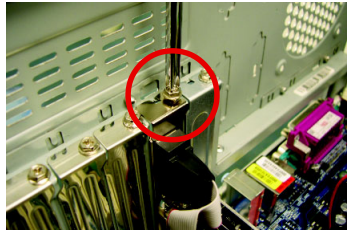

3. Plug the display cable into your card; then turn on the computer and monitor.

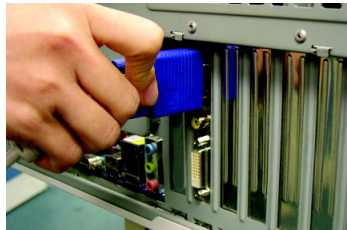

3. Software Installation

3.1. DirectX Installation

Install Microsoft DirectX to enable 3D hardware acceleration support for Windows® 98/ 98SE / Windows® 2000/ Windows® ME or Windows® XP to achieve better 3D performance.



Note: For software MPEG support in Windows® 98/ 98SE/ Windows® 2000/ Windows® ME or Windows® XP, you must install DirectX first.



Click "Install DirectX 9" item.

3.2. Driver Installation (Windows® XP/2000/ME/98)

Insert the driver CD disk into your CD-ROM, and then you can see the AUTORUN window. If it does not show up, please run "D:\setup.exe". (We assume that your CD-ROM drive letter to be D:).



Click "Install Display Driver" item.

3.3. V-Tuner Installation

V-Tuner lets you adjust the working frequency of the graphic engine and video memory (Core Clock and Memory Clock).



Click "Utilities" item.

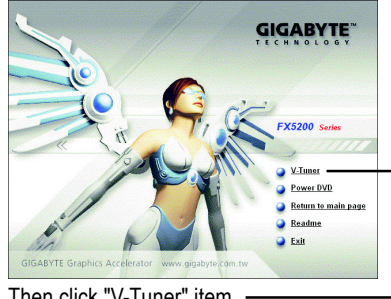

Then click "V-Tuner" item.

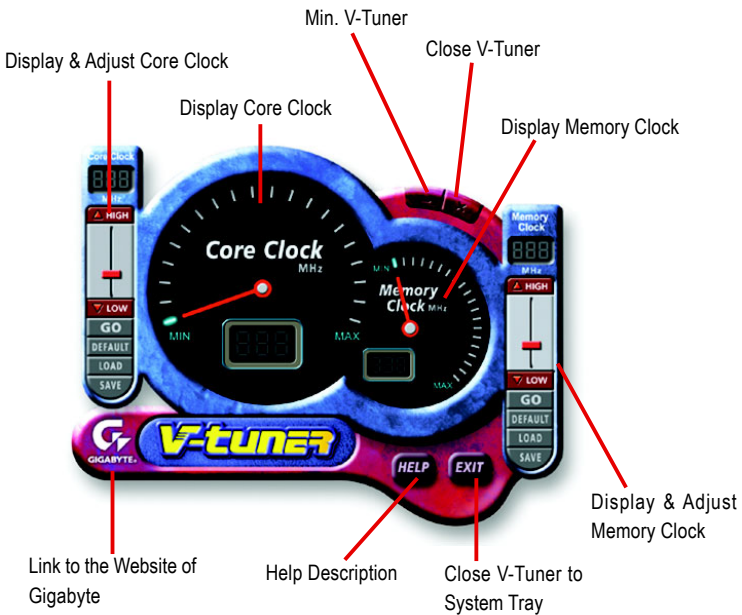

4. Appendix

4.1. BIOS Flash Utility

1. Please download the newest BIOS Zip file for your graphics card from GIGABYTE website. The file includes a MS-DOS-based BIOS flash utility. Or contact your local dealer for the file.

4.2. How to Reflash BIOS in MS-DOS mode

1. Extract the downloaded Zip file to your hard disk(s) (ex: drive C) or floppy disk. This procedure assumes drive C.
2. Restart the computer in MS-DOS mode by choosing "Restart in MS-DOS mode" in the Shut Down Windows dialog box. (This option is only available with Windows 98/98SE. For Windows 2000/ME/XP, you need a startup disk to restart the computer in MS-DOS mode.)
3. Change the command prompt to C:\>.
4. Back up the current BIOS by typing **gvf13 -s filename** at the C:\> prompt and press **Enter**.
5. Begin to flash BIOS by typing **gvf13 -p filename (ex:n55128d.f1)** at the C:\> prompt and press **Enter**.
6. Restart your computer when it's done.

4.3. Resolutions and Color Depth Table (In Windows® XP)

Display Screen Resolution	Maximum Refresh Rate (Hz)	Color Depth (bpp)		
		8bpp (256 color) Standard mode	16bpp (65K color) High mode	32bpp (16.7M color) True mode
320 x 200	75	✓	✓	✓
320 x 240	75	✓	✓	✓
400 x 300	75	✓	✓	✓
480 x 360	75	✓	✓	✓
512 x 384	75	✓	✓	✓
640 x 400	75	✓	✓	✓
640 x 480	240	✓	✓	✓
720 x480	60	✓	✓	✓
720 x 576	60	✓	✓	✓
800 x 600	240	✓	✓	✓
848 x 480	240	✓	✓	✓
960 x 600	240	✓	✓	✓
1024 x 768	240	✓	✓	X
1088 x 612	240	✓	✓	X
1152 x 864	200	✓	✓	X
1280 x 720	170	✓	✓	X
1280 x 768	170	✓	✓	X
1280 x 800	170	✓	✓	X
1280 x 960	170	✓	✓	X
1280 x 1024	170	✓	✓	X
1360 x 768	170	✓	✓	X
1600 x 900	150	✓	✓	X
1600 x 1024	120	✓	✓	X
1600 x 1200	120	✓	✓	X
1920 x 1080	100	✓	✓	X
1920 x 1200	100	✓	✓	X
1920 x 1440	85	✓	✓	✓
2048 x 1536	85	✓	✓	✓

* This table is for reference only. The actual resolutions supported depend on the monitor you use.