

# GS-W42G-P08R

## User's Manual

Rev. 1001

28A08-0W08M-0CAR



To reduce the impacts on global warming, the packaging materials of this product are recyclable and reusable. GIGABYTE works with you to protect the environment.

**GIGABYTE™** Giga-Byte Technology B.V.  
**Declaration of Conformity**

We, Manufacturer/Importer,  
 Giga-Byte Technology B.V.  
 Address: **Slooterveen 24, 5628 DK, Eindhoven, The Netherlands**  
 Declare that the product  
 Product Type: **Workstation**  
 Product Name: **GS-W42G-P08R**  
 conforms to the essential requirements of the following directives:

**EMC Directive 2014/53/EU:**

<input checked="" type="checkbox"/> Conduction & Radiated Emissions:	EN 55032:2012+AC:2013
<input checked="" type="checkbox"/> Immunity:	EN 55024:2010+A1:2015
<input checked="" type="checkbox"/> Power-line harmonics:	EN 61000-3-2:2014
<input checked="" type="checkbox"/> Power-line filter:	EN 61000-3-3:2013

**Low Voltage Directive 2014/35/EU:**

<input checked="" type="checkbox"/> Safety:	EN60950-1:2009+A11:2009+A12:2011+A2:2013
---------------------------------------------	------------------------------------------

**RoHS Directive 2011/65/EU:**

<input checked="" type="checkbox"/> Restriction of use of certain substances in electronic equipment:	This product does not contain any of the restricted substances listed in Annex II, in concentrations and applications banned by the directive.
-------------------------------------------------------------------------------------------------------	------------------------------------------------------------------------------------------------------------------------------------------------

**CE marking**

**CE**

Signature: 

Date: Jul. 22, 2019 Name: Lien Chih-Hsin

Giga-Byte Technology B.V. Tel: +31 40 2902088 K.v.k. Ondernemers Nr. 17136359  
 Slooterveen 24, Fax: +31 40 2902089 V.A.T. number: NL00903205801  
 5628 DK, Eindhoven, The Netherlands Email: info@gbt.com.tw

USD - CITIBANK TAIWAN SWIF: CITITW33 Agency: 568712059  
 EURO - CITIBANK AMSTERDAM SWIF: CITIEN22 IBAN: NL7501006022890

**Federal Communications Commission  
 Supplier's Declaration of Conformity**

This supplier's declaration of conformity is hereby for  
 Product: Workstation  
 Model Number(s): GS-W42G-P08R  
 Brand/Trade: GIGABYTE

We declare under our sole responsibility that the above mentioned device has been tested and found in compliance with CFR 47 PART 15 REGULATION.

THIS DEVICE COMPLIES WITH PART 15 OF THE FCC RULES. OPERATION IS SUBJECT TO THE FOLLOWING TWO CONDITIONS:  
 (1) THIS DEVICE MAY NOT CAUSE HARMFUL INTERFERENCE AND,  
 (2) THIS DEVICE MUST ACCEPT ANY INTERFERENCE RECEIVED, INCLUDING INTERFERENCE THAT MAY CAUSE UNDESIRABLE OPERATION.

**Responsible Party – U.S. Contact Information**  
 Company: G.B.T.INC.(U.S.A)  
 Address: 17358 Railroad Street City of Industry, CA 91748

Country: U.S.A.  
 Telephone No: (626)854-9338 / (626)854-9326  
 Name: Eric Lu Title: General Manager  
 Signature: \_\_\_\_\_ Date: Jul. 22, 2019

**Representative of Responsible Party for SDOc**  
 Company: G.B.T.INC.(U.S.A)  
 Address: 17358 Railroad Street City of Industry, CA 91748

Country: U.S.A.  
 Telephone No: (626)854-9338 / (626)854-9326  
 Name: Eric Lu Title: General Manager  
 Signature:  Date: Jul. 22, 2019

**FC** This device complies with Part 15 of the FCC Rules. Operation is subject to the following two conditions: (1) this device may not cause harmful interference, and (2) this device must accept any interference received, including interference that may cause undesired operation.

**Warning:** This is a Class A product. In a domestic environment, this product may cause radio interference in which case the user may be required to take adequate measures.

**CE** **Warning:** This is a Class A product. In a domestic environment, this product may cause radio interference, in which case the user may be required to take appropriate measures.



**Copyright**

© 2019 GIGA-BYTE TECHNOLOGY CO., LTD. All rights reserved.

The trademarks mentioned in this manual are legally registered to their respective owners.

**Disclaimer**

Information in this manual is protected by copyright laws and is the property of GIGABYTE. Changes to the specifications and features in this manual may be made by GIGABYTE without prior notice. No part of this manual may be reproduced, copied, translated, transmitted, or published in any form or by any means without GIGABYTE's prior written permission.

**Documentation Classifications**

In order to assist in the use of this product, GIGABYTE provides the following types of documentations:

- For quick set-up of the product, read the Quick Installation Guide included with the product.
- For detailed product information, carefully read the User's Manual.

For product-related information, check on our website at: <https://www.gigabyte.com>

## Server Warnings and Cautions

Before installing a server, be sure that you understand the following warnings and cautions.



### WARNING!

**To reduce the risk of electric shock or damage to the equipment:**

- Do not disable the power cord grounding plug. The grounding plug is an important safety feature.
- Plug the power cord into a grounded (earthed) electrical outlet that is easily accessible at all times.
- Unplug the power cord from the power supply to disconnect power to the equipment.
- Do not route the power cord where it can be walked on or pinched by items placed against it. Pay particular attention to the plug, electrical outlet, and the point where the cord extends from the server.



### WARNING!

**To reduce the risk of personal injury from hot surfaces, allow the drives and the internal system components to cool before touching them.**



### WARNING!

**This server is equipped with high speed fans. Keep away from hazardous moving fan blades during servicing.**



### CAUTION!

- Do not operate the server for long periods with the access panel open or removed. Operating the server in this manner results in improper airflow and improper cooling that can lead to thermal damage.
- Danger of explosion if battery is incorrectly replaced.
- Replace only with the same or equivalent type recommended by the manufacturer.
- Dispose of used batteries according to the manufacturer's instructions.

## Electrostatic Discharge (ESD)



### CAUTION!

ESD CAN DAMAGE DRIVES, BOARDS, AND OTHER PARTS. WE RECOMMEND THAT YOU PERFORM ALL PROCEDURES AT AN ESD WORKSTATION. IF ONE IS NOT AVAILABLE, PROVIDE SOME ESD PROTECTION BY WEARING AN ANTI-STATIC WRIST STRAP ATTACHED TO CHASSIS GROUND -- ANY UNPAINTED METAL SURFACE -- ON YOUR SERVER WHEN HANDLING PARTS.

Always handle boards carefully. They can be extremely sensitive to ESD. Hold boards only by their edges without any component and pin touching. After removing a board from its protective wrapper or from the system, place the board component side up on a grounded, static free surface. Use a conductive foam pad if available but not the board wrapper. Do not slide board over any surface.

**System power on/off:** To remove power from system, you must remove the system from rack. Make sure the system is removed from the rack before opening the chassis, adding, or removing any non hot-plug components.

**Hazardous conditions, devices and cables:** Hazardous electrical conditions may be present on power, telephone, and communication cables. Turn off the system and disconnect the cables attached to the system before servicing it. Otherwise, personal injury or equipment damage can result.

**Installing or removing jumpers:** A jumper is a small plastic encased conductor that slips over two jumper pins. Some jumpers have a small tab on top that can be gripped with fingertips or with a pair of fine needle nosed pliers. If the jumpers do not have such a tab, take care when using needle nosed pliers to remove or install a jumper; grip the narrow sides of the jumper with the pliers, never the wide sides. Gripping the wide sides can damage the contacts inside the jumper, causing intermittent problems with the function controlled by that jumper. Take care to grip with, but not squeeze, the pliers or other tool used to remove a jumper, or the pins on the board may bend or break.



### CAUTION!

Risk of explosion if battery is replaced incorrectly or with an incorrect type. Replace the battery only with the same or equivalent type recommended by the manufacturer. Dispose of used batteries according to the manufacturer's instructions.

# Table of Contents

Chapter 1 Model Lineup.....	6
1-1 System Components.....	6
Chapter 2 Hardware Installation .....	7
2-1 Installation Precautions .....	7
2-2 Server System Features .....	8
2-3 Content Specifications .....	9
2-4 Motherboard Layout .....	11
2-5 Motherboard Block Diagram .....	12
Chapter 3 System Appearance .....	13
3-1 Front View and LEDs .....	13
3-2 Power Supply LEDs .....	15
3-3 Back Panel Connectors.....	16
Chapter 4 System Hardware Installation .....	17
4-1 Removing Chassis Cover.....	18
4-2 Installing the CPU and Heatsink .....	19
4-3 Installing the Memory.....	20
4-4 Installing the PCI Express Card .....	22
4-5 Installing the Hard Drive.....	24
4-6 Installing the Redundant Power Supply .....	26
4-7 Installing the Chassis Feet .....	27
4-8 Back Panel Connectors.....	28
4-9 Internal Connectors.....	30
Chapter 5 BIOS Setup .....	40
5-1 Startup Screen .....	40
5-2 Main .....	41
5-3 Advanced .....	42
5-4 Platform Configuration .....	45
5-5 Socket Configuration.....	47
5-6 Server Mgmt.....	52
5-7 Security .....	54
5-8 Boot.....	55
5-9 Save & Exit.....	56
Chapter 6 BMC Web.....	57
Contact Us .....	72

# Chapter 1 Model Lineup

## 1-1 System Components

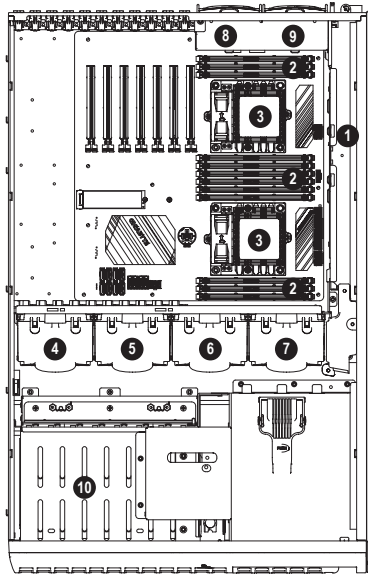

1	Power Supply Unit	6	System fan #3
2	DDR4 Memory	7	System fan #4
3	CPU	8	System fan #5
4	System fan #1	9	System fan #6
5	System fan #2	10	Hard Disk Drives

### Box Contents

- GS-W42G-P08R Barebone
- Driver disc
- Quick installation guide
- User's manual
- Two CPU Heatsinks
- USB3.0 Daughter Card
- Two Chassis Feet
- Two Power Cords

## Chapter 2 Hardware Installation

### 2-1 Installation Precautions

The motherboard/system contain numerous delicate electronic circuits and components which can become damaged as a result of electrostatic discharge (ESD). Prior to installation, carefully read the user's manual and follow these procedures:









- Prior to installation, do not remove or break motherboard S/N (Serial Number) sticker or warranty sticker provided by your dealer. These stickers are required for warranty validation.
- Always remove the AC power by unplugging the power cord from the power outlet before installing or removing the motherboard or other hardware components.
- When connecting hardware components to the internal connectors on the motherboard, make sure they are connected tightly and securely.
- When handling the motherboard, avoid touching any metal leads or connectors.
- It is best to wear an electrostatic discharge (ESD) wrist strap when handling electronic components such as a motherboard, CPU or memory. If you do not have an ESD wrist strap, keep your hands dry and first touch a metal object to eliminate static electricity.
- Prior to installing the motherboard, please have it on top of an antistatic pad or within an electrostatic shielding container.
- Before connecting or unplugging the power supply cable from the motherboard, make sure the power supply has been turned off.
- Before turning on the power, make sure the power supply voltage has been set according to the local voltage standard.
- Before using the product, please verify that all cables and power connectors of your hardware components are connected.
- To prevent damage to the motherboard, do not allow screws to come in contact with the motherboard circuit or its components.
- Make sure there are no leftover screws or metal components placed on the motherboard or within the computer casing.
- Do not place the computer system on an uneven surface.
- Do not place the computer system in a high-temperature or wet environment.
- Turning on the computer power during the installation process can lead to damage to system components as well as physical harm to the user.
- If you are uncertain about any installation steps or have a problem related to the use of the product, please consult a certified computer technician.
- If you use an adapter, extension power cable, or power strip, ensure to consult with its installation and/or grounding instructions.

## 2-2 Server System Features

- Remote KVM (Graphics console and HTML5 support)
- Virtual Media and Media Redirection (ISO images)
- Remote server power control
- Remote Serial over LAN (Text console)
- Event Log and Alerting support
- Automatic Notification and Alerts (SNMP and email)
- Hardware Monitoring (Thermal sensors, fan speed, voltage...)
- HDD status Management (Backline with MCU)
- Out of band management through shared or dedicated LAN
- Option to change LAN connection interface at Runtime
- VLAN
- RMCP & RMCP+ protocols supported
- SMASH/CLP
- RADIUS authentication support
- Secure browser interface (Secure socket layer - SSL support)
- Upgrade the BIOS/BMC Firmware (Web interface / command line)
- WSMAN and WS-CIM
- Fan Group Duty control
- Lightweight Directory Access Protocol (LDAP) supported
- IPMI 2.0-BASED MANAGEMENT
- DCMI support
- Backup and restore the configuration file
- Factory defaults from web support
- Record video and play
- Server data/information
- OS-independent



## 2-3 Content Specifications

	CPU	<ul style="list-style-type: none"> <li>◆ Support for 1st and 2nd Generation Intel® Xeon® Scalable Processors in the LGA 3647 package</li> <li>◆ Dual Socket P (Square) with 2 UPI support of up to 10.4 GT/s, CPU TDP support up to 205W</li> </ul>
	Chipset	<ul style="list-style-type: none"> <li>◆ Intel® C621 Chipset</li> </ul>
	Memory	<ul style="list-style-type: none"> <li>◆ 12 x DDR4 DIMM sockets supporting up to 1.5 TB of system memory</li> <li>◆ 6 channel memory architecture (6 channel per CPU)</li> <li>◆ Support for DDR4 2666 MHz memory modules if use a Skylake CPU</li> <li>◆ Support for DDR4 2933 MHz memory modules if use a Cascade lake CPU</li> <li>◆ Support for ECC RDIMM/RDIMM 3DS/LRDIMM/LRDIMM 3DS memory modules</li> </ul>
	Audio	<ul style="list-style-type: none"> <li>◆ Realtek® ALC1220-VB codec</li> <li>◆ High Definition Audio</li> <li>◆ 2/4/5.1/7.1-channel</li> <li>◆ Support for S/PDIF Out</li> </ul>
	LAN	<ul style="list-style-type: none"> <li>◆ 2 x Intel® 210AT GbE LAN chips (10/100/1000 Mbit)</li> </ul>
	Expansion Slots	<ul style="list-style-type: none"> <li>◆ 4 x PCI Express x16 slots, running at x16</li> <li>◆ 3 x PCI Express x16 slots, running at x8 (All of the PCI Express x16 slots conform to PCI Express 3.0 standard.)</li> </ul>
	Storage	<ul style="list-style-type: none"> <li>◆ Front Side: 8 x 3.5" SATA hot-swappable HDD bays (Onboard)</li> <li>◆ Front Side: 2 x 3.5" NVMe hot-swappable HDD bays (Onboard)</li> <li>◆ Front Side (Option): 8x3.5" SAS hot-swappable HDD bays (Add-in SAS HBA Card)</li> <li>◆ Front Side (Option): 4x3.5" NVMe hot-swappable HDD bays</li> <li>◆ Internal: 2 x 3.5" HDD bays (Onboard)</li> </ul>
	USB	<ul style="list-style-type: none"> <li>◆ Chipset: <ul style="list-style-type: none"> <li>- 1 x USB Type-C™ port on the back panel, with USB 3.1 Gen 2 support</li> <li>- 1 x USB 3.1 Gen 2 Type-A ports (red) on the back panel</li> <li>- 7 x USB 3.1 Gen 1 ports (4 ports on the back panel, 1 port onboard, 2 ports available through the internal USB header)</li> <li>- 2 x USB 2.0/1.1 ports available through the internal USB header</li> </ul> </li> </ul>
	Internal Connectors	<ul style="list-style-type: none"> <li>◆ 1 x 24-pin ATX main power connector</li> <li>◆ 2 x 8-pin ATX 12V power connectors</li> <li>◆ 1 x 6-pin ATX 12V power connector</li> <li>◆ 2 x CPU fan headers</li> <li>◆ 5 x system fan headers</li> <li>◆ 1 x M.2 Socket 3 connector</li> <li>◆ 10 x SATA 6Gb/s connectors</li> <li>◆ 2 x U.2 connectors</li> <li>◆ 2 x SATA DOM power headers</li> <li>◆ 1 x PMBus connector</li> <li>◆ 1 x Intel® VROC Upgrade Key header</li> <li>◆ 1 x front panel header</li> <li>◆ 1 x front panel audio header</li> <li>◆ 1 x USB 3.1 Gen 1 header</li> <li>◆ 1 x USB 3.1 Gen 1 port</li> <li>◆ 1 x USB 2.0/1.1 header</li> <li>◆ 1 x Trusted Platform Module (TPM) header</li> <li>◆ 1 x serial port connector</li> </ul>

	Internal Connectors	<ul style="list-style-type: none"> <li>◆ 1 x chassis intrusion header</li> <li>◆ 3 x SATA SGPIO headers</li> <li>◆ 1 x SMD_VMD header</li> <li>◆ 1 x IPMB connector</li> <li>◆ 1 x SMB connector</li> <li>◆ 1 x TBT connector</li> <li>◆ 1 x BMC_UART connector</li> <li>◆ 1 x VGA connector</li> <li>◆ 1 x wake on LAN header</li> <li>◆ 1 x speaker header</li> <li>◆ 1 x Clear CMOS jumper</li> <li>◆ 1 x VGA jumper</li> <li>◆ 1 x Watch-Dog timer jumper</li> <li>◆ 1 x VRM SMB Clock jumper</li> <li>◆ 1 x VRM SMB Data jumper</li> <li>◆ 1 x power button</li> <li>◆ 1 x reset button</li> </ul>
	Back Panel Connectors	<ul style="list-style-type: none"> <li>◆ 1 x PS/2 keyboard/mouse port</li> <li>◆ 1 x USB Type-C™ port, with USB 3.1 Gen 2 support</li> <li>◆ 1 x USB 3.1 Gen 2 Type-A port (red)</li> <li>◆ 4 x USB 3.1 Gen 1 ports</li> <li>◆ 2 x USB 2.0/1.1 ports</li> <li>◆ 2 x RJ-45 ports</li> <li>◆ 1 x optical S/PDIF Out connector</li> <li>◆ 5 x audio jacks</li> </ul>
	I/O Controller	<ul style="list-style-type: none"> <li>◆ ASPEED® AST2500 BMC chip</li> </ul>
	Power Supply	<ul style="list-style-type: none"> <li>◆ 2 x 2000W Redundant Power</li> <li>◆ 80 PLUS Platinum</li> <li>◆ AC Input: <ul style="list-style-type: none"> <li>- 100-127V/ 12-9.5A, 50-60Hz</li> <li>- 200-240V/ 10-9.8A, 50-60Hz</li> </ul> </li> <li>◆ DC Output: <ul style="list-style-type: none"> <li>- MAX 2800W</li> <li>- +12V/1~212A</li> <li>- +5Vsb/0~6.5A</li> <li>- +5V/0.3~30A</li> <li>- +3V3/0.3~24A</li> <li>- -12V/0~0.6A</li> </ul> </li> </ul>
	BIOS	<ul style="list-style-type: none"> <li>◆ 1 x 256 Mbit flash</li> <li>◆ Use of licensed AMI BIOS</li> <li>◆ PnP 1.0a, DMI 2.7, WfM 2.0, SM BIOS 2.7, ACPI 5.0</li> </ul>
	Operating Properties	<ul style="list-style-type: none"> <li>◆ Operating temperature: 10°C to 35°C</li> <li>◆ Operating humidity: 8 - 80%</li> <li>◆ Non-operating temperature: -40°C to 60°C</li> <li>◆ Non-operating humidity: 5% - 95%</li> </ul>
	System Dimension	<ul style="list-style-type: none"> <li>◆ 4U</li> <li>◆ 177.00mm (W) x 448.45mm (H) x 687.20mm (D)</li> </ul>

\* GIGABYTE reserves the right to make any changes to the product specifications and product-related information without prior notice.

## 2-4 Motherboard Layout

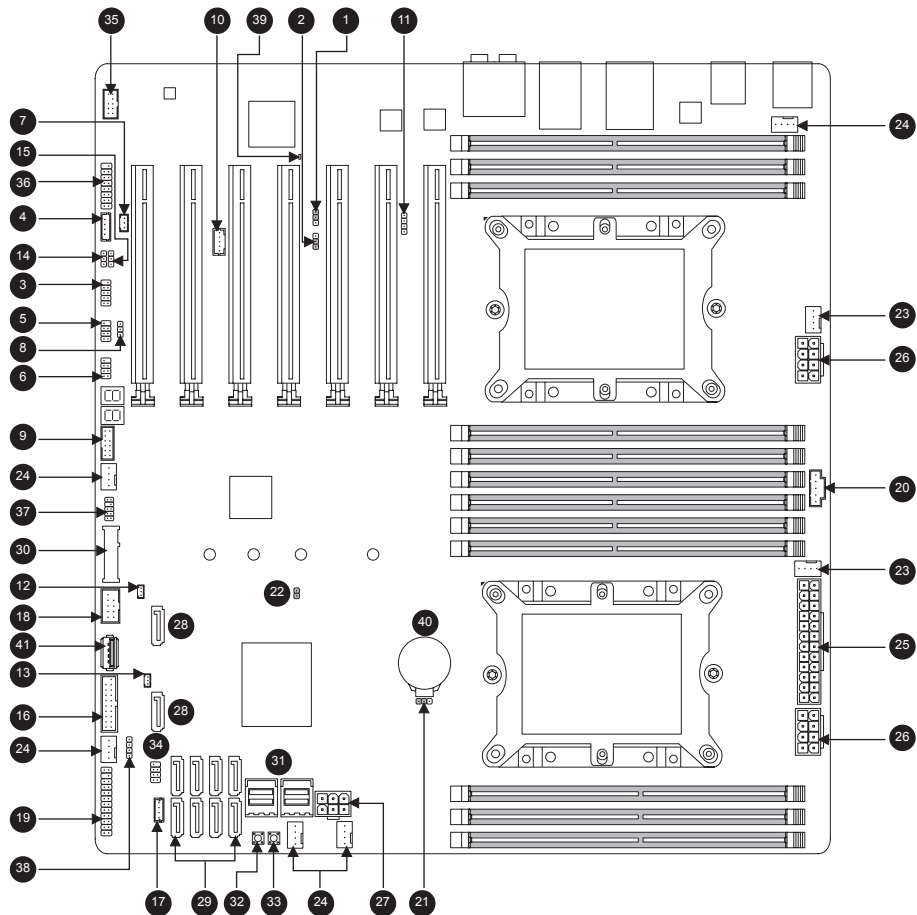

1	BMC_VGA	12	SATA_DOM0	23	CPU_FAN1~2	34	S_SGPIIO
2	BMC_WATCHD	13	SATA_DOM1	24	SYS_FAN1~5	35	F_AUDIO
3	COM	14	VRM_SCL	25	ATX	36	VGA
4	SMB_IPMB	15	VRM_SDA	26	ATX8P_1~2	37	SMB_VMD
5	I_SGPIIO1	16	FUSB30	27	ATX12V 6P	38	SPEAKER
6	I_SGPIIO2	17	VROC	28	S-SATA0~1	39	BMC_LED2
7	WOL	18	FUSB2	29	I-SATA0~7	40	BAT
8	SMB	19	F_PANEL	30	PCIEX4_M2	41	USB 3.0
9	TPM	20	PMBUS	31	U2_1~2		
10	TBT	21	CLR_CMOS	32	PWR_SW		
11	BMC_UART	22	CI	33	RST_SW		

## 2-5 Motherboard Block Diagram

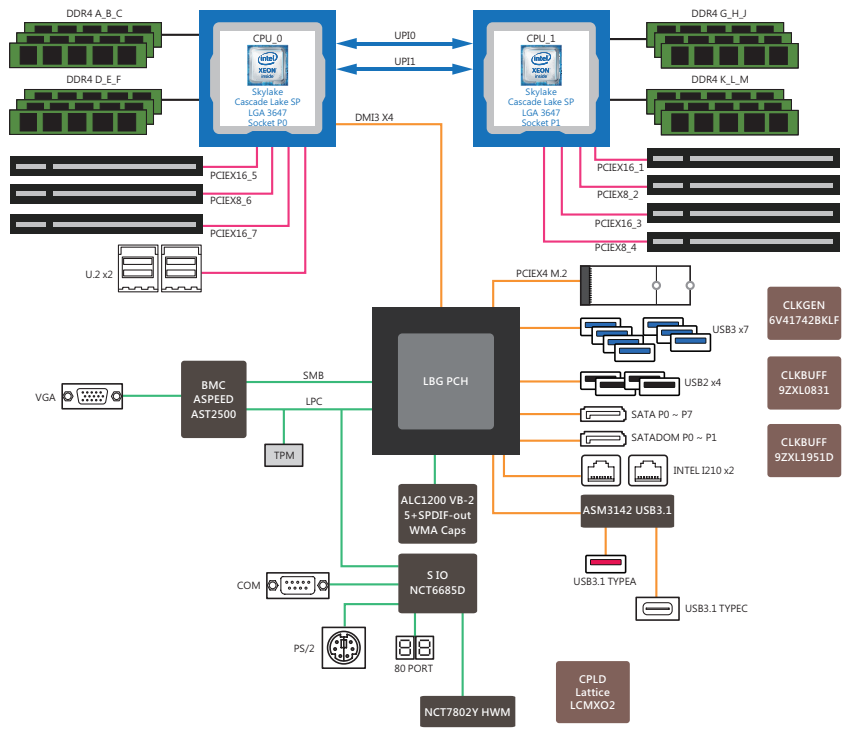

## Chapter 3 System Appearance

### 3-1 Front View and LEDs

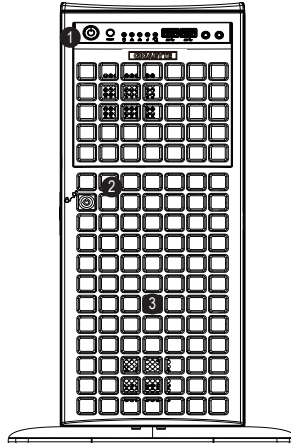

#### Front Chassis Features:

No.	Feature	Description
1	Control Panel	Front control panel.
2	Bezel Lock	Locks the bezel for secure access.
3	Hot-swap Drive Bays	Eight 3.5" drive bays

## Control Panel

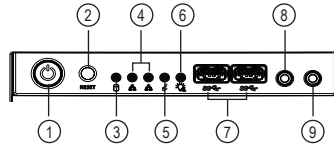

### Control Panel Features:

No.	Feature	Description
1	Power Button	The main power switch is used to apply or remove power from the power supply to the server. Turning off system power with this button removes the main power but maintains standby power. To perform many maintenance tasks, you must unplug system before servicing.
2	Reset Button	The reset button is used to reboot the system.
3	HDD LED	Indicates hard drive activity on the hard drive when flashing
4	NIC LED	Indicates network activity on LAN when flashing
5	Information LED	Alerts operator of several states. See table below for details.
6	Power Fail	Indicates a power failure to the system's power supply units.
7	USB 3.0	Two USB 3.0 ports.
8	Line Out	Line out port.
9	Mic	Mic port.

### Information LED:

Status	Description
Solid red	An overheat condition has occurred. (This may be caused by cable congestion.)
Blinking red	Fan failure, check for an inoperative fan.
Solid blue	UID has been activated.

## Hard Disk Drive LEDs

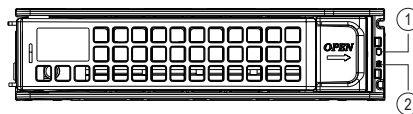

No.	Name	Color
1	LED 1	Activity LED
2	LED 2	Fault LED

## 3-2 Power Supply LEDs

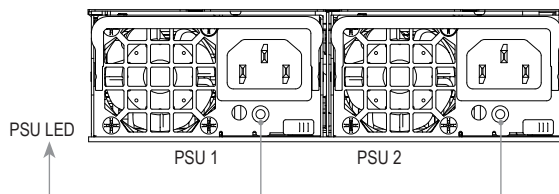

### Redundant PSU LED:

LED Status	Description
Off	No AC power to all power supplies
1Hz Blinking Green	AC present/only standby output on
Green	DC output ON and OK
Red	Power supply critical event causing a shutdown; failure, OCP, OVP, Fan fail
1Hz Blinking Red	No AC power to this PSU only (for 1+1 configuration)
1Hz Blinking Red/Green	Power supply warning events where the power supply continues to operate high temp, high power, high current, slow fan

Note: Blinking frequency: 1 sec. ON / 1 sec. OFF

### 3-3 Back Panel Connectors

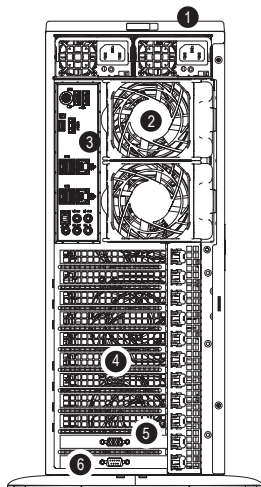

#### Back Chassis Features:

No.	Feature	Description
1	Power Supply	2 x 2000W redundant power supply with PMBus
2	Fans	Two rear fans
3	I/O Back Panel	Back I/O Ports
4	Expansion Slots	Nine PCI-E expansion card slots
5	D-Sub Port	Connect a monitor that supports D-Sub connection to this port.
6	Serial Port	Use the serial port to connect devices such as a mouse, modem or other peripherals.



## Chapter 4 System Hardware Installation



### Pre-installation Instructions

Computer components and electronic circuit boards can be damaged by discharges of static electricity. Working on computers that are still connected to a power supply can be extremely dangerous. Follow the simple guidelines below to avoid damage to your computer or injury to yourself.

- Always disconnect the computer from the power outlet whenever you are working inside the computer case.
- If possible, wear a grounded wrist strap when you are working inside the computer case. Alternatively, discharge any static electricity by touching the bare metal system of the computer case, or the bare metal body of any other grounded appliance.
- Hold electronic circuit boards by the edges only. Do not touch the components on the board unless it is necessary to do so. Do not flex or stress the circuit board.
- Leave all components inside the static-proof packaging until you are ready to use the component for the installation.

## 4-1 Removing Chassis Cover



Before you remove or install the system cover

- Make sure the system is not turned on or connected to AC power.

Follow these instructions to remove the chassis covers:

1. Remove two screws from each side.
2. Push the Main Cover Handle.
3. Lift up and back on the main cover handle, which secures the cover to the chassis.
4. Lift the main cover off of the chassis.

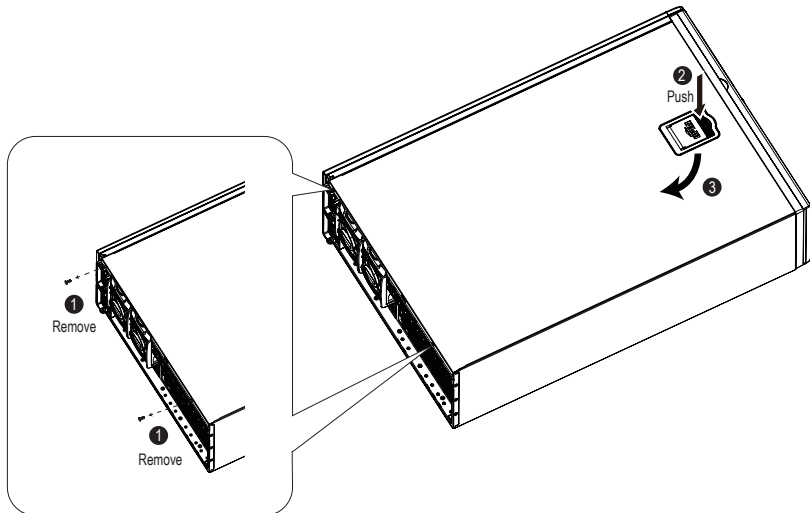

## 4-2 Installing the CPU and Heatsink



Read the following guidelines before you begin to install the CPU:

- Make sure that the motherboard supports the CPU.
- Always turn off the computer and unplug the power cord from the power outlet before installing the CPU to prevent hardware damage.
- Unplug all cables from the power outlets.
- Disconnect all telecommunication cables from their ports.
- Place the system unit on a flat and stable surface.
- Open the system according to the instructions.



### WARNING!

Failure to properly turn off the server before you start installing components may cause serious damage. Do not attempt the procedures described in the following sections unless you are a qualified service technician.

Follow these instructions to install the CPU:

1. Align and install the processor on the carrier.  
**NOTE:** Apply thermal compound evenly on the top of the CPU. Remove the protective cover from the underside of the heatsink.
2. Carefully flip the heatsink. Then install the carrier assembly on the bottom of the heatsink and make sure the gold arrow is located in the correct direction.
3. Remove the CPU cover.  
**NOTE:** Save and replace the CPU cover if the processor is removed from its socket.
4. Align the heatsink with the CPU socket by the guide pins and make sure the gold arrow is located in the correct direction. Then place the heatsink onto the top of the CPU socket.
5. To secure the heatsink, tighten the screws in a sequential order (①→②→③→④).  
**NOTE:** When disassembling the heatsink, loosen the screws in reverse order (④→③→②→①).

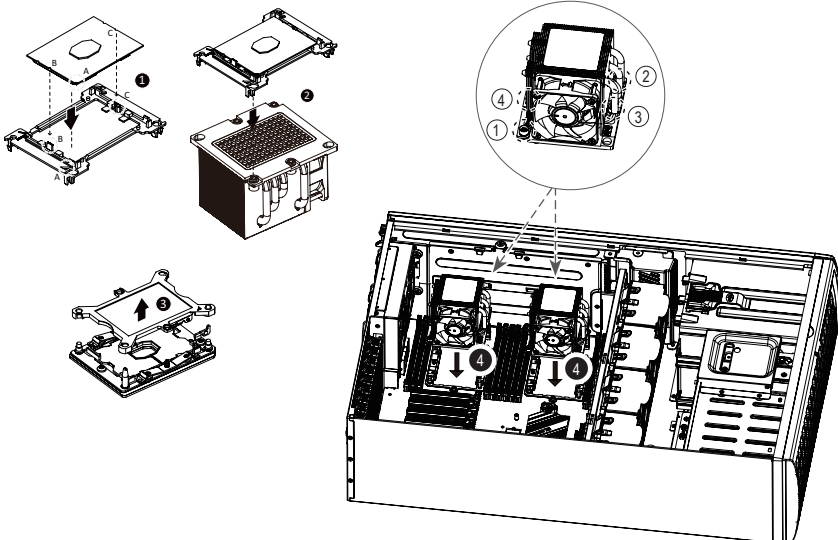

## 4-3 Installing the Memory



Read the following guidelines before you begin to install the memory:

- Make sure that the motherboard supports the memory. It is recommended that memory of the same capacity, brand, speed, and chips be used.
- Always turn off the computer and unplug the power cord from the power outlet before installing the memory to prevent hardware damage.
- Memory modules have a foolproof design. A memory module can be installed in only one direction. If you are unable to insert the memory, switch the direction.

### Four Channel Memory Configuration

This motherboard supports 6 Channel Technology. After the memory is installed, the BIOS will automatically detect the specifications and capacity of the memory.

The twelve DDR4 memory sockets are divided into 6 channels and each channel has two memory sockets as following:

- ▶▶ Channel 1: P1-DIMM-A1 (For CPU 1)/P2-DIMM-G1 (For CPU 2)
- ▶▶ Channel 2: P1-DIMM-B1 (For CPU 1)/P2-DIMM-H1 (For CPU 2)
- ▶▶ Channel 3: P1-DIMM-C1 (For CPU 1)/P2-DIMM-J1 (For CPU 2)
- ▶▶ Channel 4: P1-DIMM-D1 (For CPU 1)/P2-DIMM-K1 (For CPU 2)
- ▶▶ Channel 5: P1-DIMM-E1 (For CPU 1)/P2-DIMM-L1 (For CPU 2)
- ▶▶ Channel 6: P1-DIMM-F1 (For CPU 1)/P2-DIMM-M1 (For CPU 2)

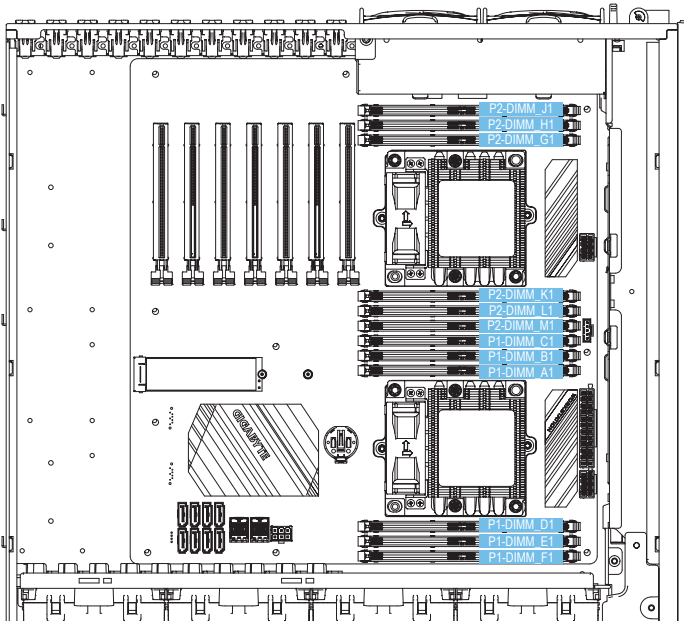

Due to CPU limitations, read the following guidelines before installing the memory in 6 Channel mode.

1. 6 Channel mode cannot be enabled if only one memory module is installed.
2. When enabling 6 Channel mode with two memory modules, it is recommended that memory of the same capacity, brand, speed, and chips be used.

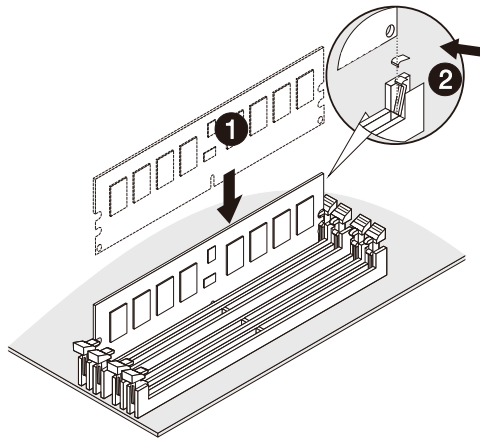

## 4-4 Installing the PCI Express Card



- Voltages can be present within the server whenever an AC power source is connected. This voltage is present even when the main power switch is in the off position. Ensure that the system is powered-down and all power sources have been disconnected from the server prior to installing a PCI card.
- Failure to observe these warnings could result in personal injury or damage to equipment.
- The PCI riser assembly does not include a riser card or any cabling as standard. To install a PCI card, a riser card must be installed.

Follow these instructions to install a PCI express card:

1. Remove the screws and then loosen the latch on the graphics card holder to remove the graphics card holder. (Refer to numbers 1~4 below)
2. Pull the latch of the case upwards and remove the screws; and then remove the metal slot cover of the expansion slot. (Refer to numbers 5~7 below)

Remove graphics card holder

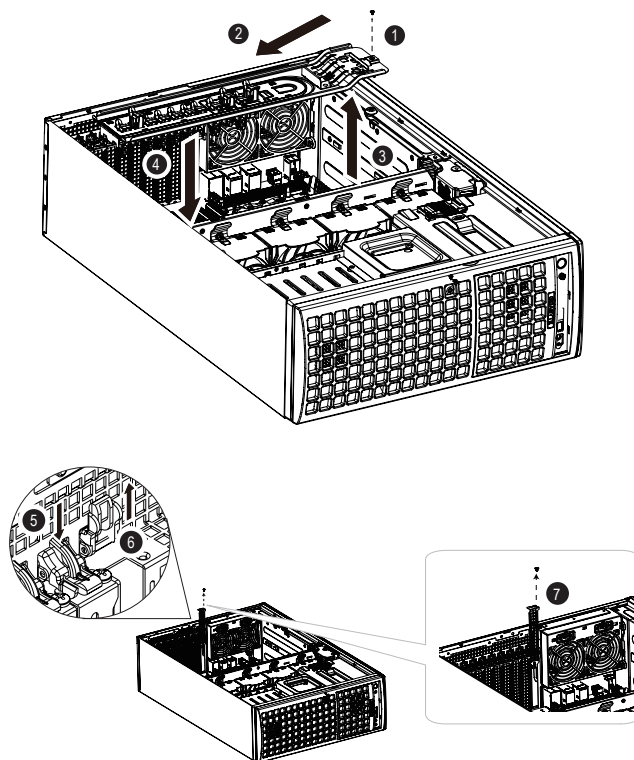



Please read the manual and precautions of the graphics card carefully before installing the graphics card.

**Follow these instructions to install a PCI express card:**

1. Install the graphics card properly, and then fix the graphics card back into the case using the screws. (Refer to numbers 1~2 below)
2. Reinstall the graphics card holder in the correct order, and lock the latch of the graphics card holder back again. Finally, tighten the screws to complete the installation. (Refer to numbers 3~4 below)

Install graphics card/holder

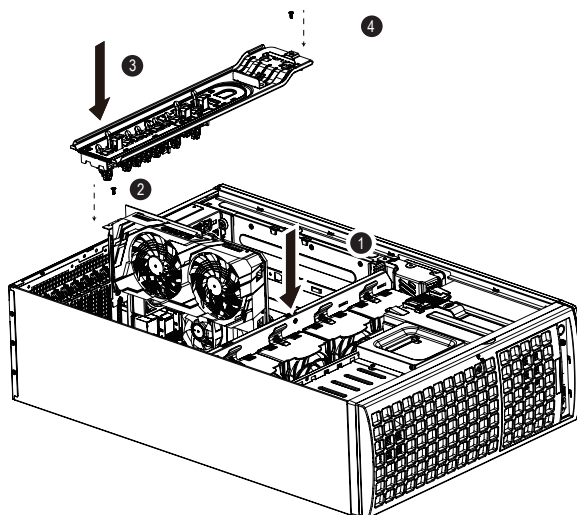

## 4-5 Installing the Hard Drive



Read the following guidelines before you begin to install the hard drive:

- Take note of the drive tray orientation before sliding it out.
- The tray will not fit back into the bay if inserted incorrectly.
- Make sure that the hard drive is connected to the hard drive connector on the backplane.

Follow these instructions to install the hard drive:

1. Unlock and open the chassis cover.
2. Press the release button to extend the drive carrier handle. Press the release button to extend the drive carrier handle.
3. Remove the screws holding the dummy drive to the drive carrier.
4. Place a hard drive in the drive carrier.
5. Secure the hard drive to the carrier using four screws.
6. Insert the hard drive into the chassis.

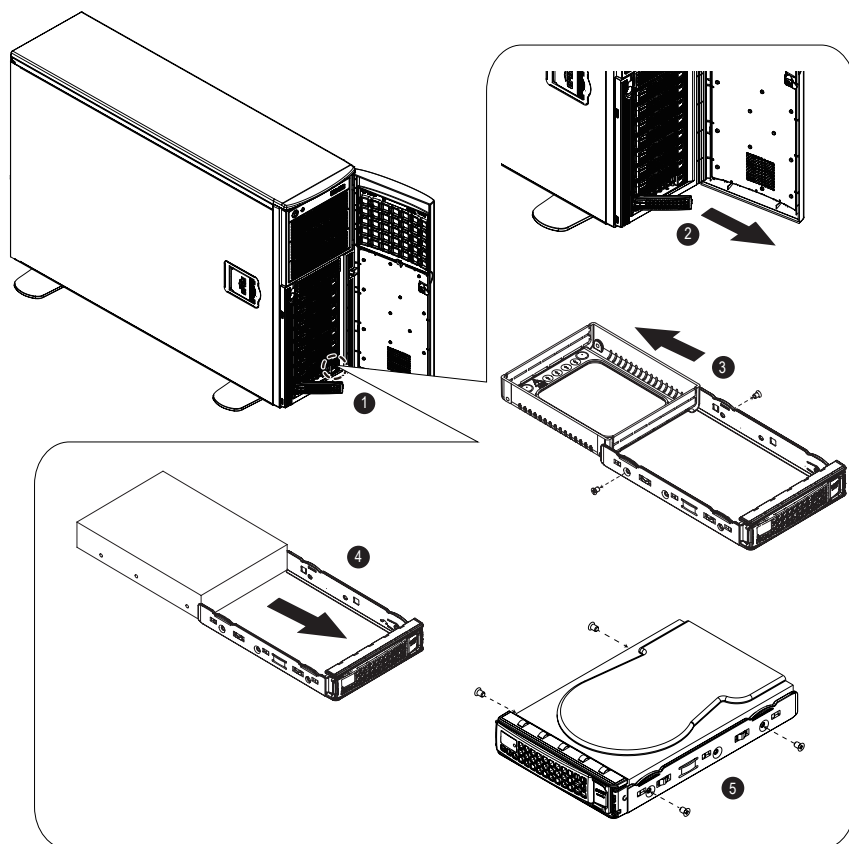



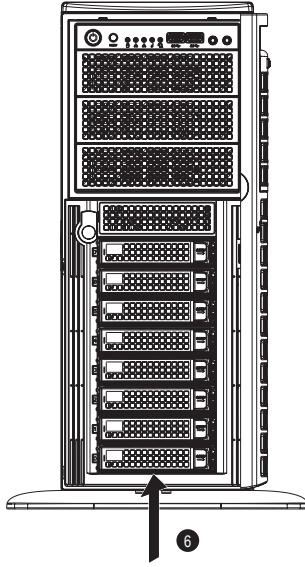

## 4-6 Installing the Redundant Power Supply



Before you remove or install the system cover, make sure the system is not turned on or connected the AC power.

**Follow these instructions to replace the power supply:**

1. Insert the replacement power supply firmly into the chassis.
2. Connect the AC power cord to the replacement power supply.

**Follow these instructions to remove the power supply:**

1. Press the release button.
2. Pull out the power supply from the chassis.

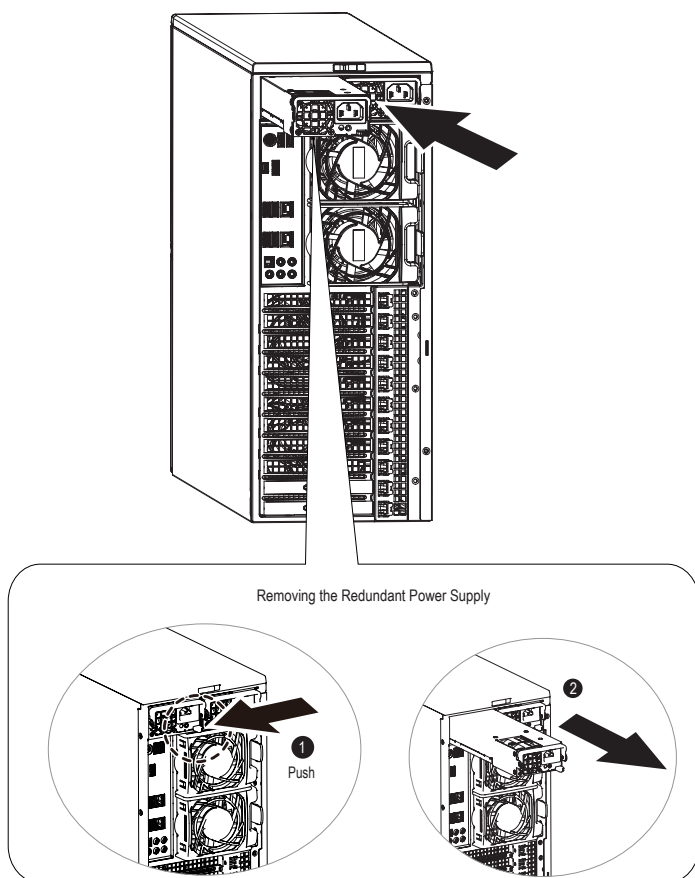

## 4-7 Installing the Chassis Feet

Follow these instructions to install the chassis feet:

1. First align the bearing latch with the holes at the bottom of the case, and then push the chassis feet to the right to fit into the holes and fix it in place.
2. Tighten the 4 screws onto the bearings of the case.

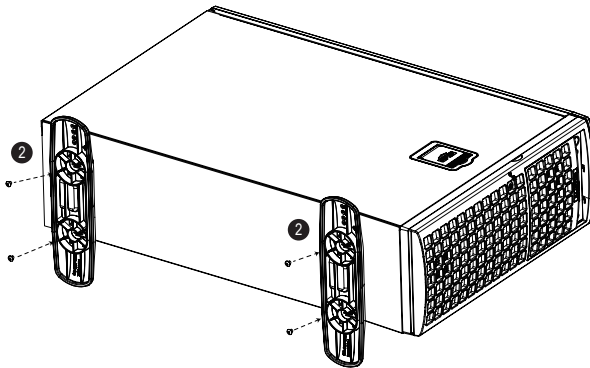
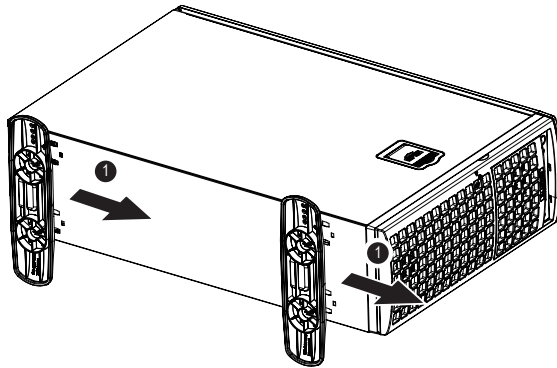

## 4-8 Back Panel Connectors

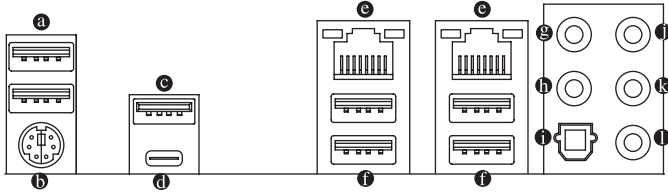

### **a** USB 2.0/1.1 Port

The USB port supports the USB 2.0/1.1 specification. Use this port for USB devices.

### **b** PS/2 Keyboard/Mouse Port

Use this port to connect a PS/2 mouse or keyboard.

### **c** USB 3.1 Gen 2 Type-A Port (Red)

The USB 3.1 Gen 2 Type-A port supports the USB 3.1 Gen 2 specification and is compatible to the USB 3.1 Gen 1 and USB 2.0 specification. Use this port for USB devices.

### **d** USB Type-C™ Port

The reversible USB port supports the USB 3.1 Gen 2 specification and is compatible to the USB 3.1 Gen 1 and USB 2.0 specification. Use this port for USB devices.

### **e** GbE LAN Port

The Gigabit Ethernet LAN port provides Internet connection at up to 1 Gbps data rate. The following describes the states of the LAN port LEDs.

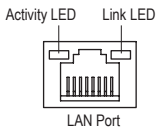

LED	State	Description
Link (Right)	Solid Green	100 Mbps data rate
	Solid Amber	1 Gbps data rate
Activity (Left)	Blinking Yellow	Active

### **f** USB 3.1 Gen 1 Port

The USB 3.1 Gen 1 port supports the USB 3.1 Gen 1 specification and is compatible to the USB 2.0 specification. Use this port for USB devices.

### **g** Center/Subwoofer Speaker Out

Use this audio jack to connect center/subwoofer speakers.

### **h** Rear Speaker Out

Use this audio jack to connect rear speakers.

### **i** Optical S/PDIF Out Connector

This connector provides digital audio out to an external audio system that supports digital optical audio. Before using this feature, ensure that your audio system provides an optical digital audio in connector.

### **j** Line In/Side Speaker Out

The line in jack. Use this audio jack for line in devices such as an optical drive, walkman, etc.

### **k** Line Out/Front Speaker Out

The line out jack. This jack supports audio amplifying function. For better sound quality, it is recommended that you connect your headphone/speaker to this jack (actual effects may vary by the device being used).

## ❶ Mic In/Side Speaker Out

The Mic in jack.

Audio Jack Configurations:

Jack	Headphone/ 2-channel	4-channel	5.1-channel	7.1-channel
Ⓔ Center/Subwoofer Speaker Out			✓	✓
Ⓘ Rear Speaker Out		✓	✓	✓
Ⓛ Line In/Side Speaker Out				✓
Ⓚ Line Out/Front Speaker Out	✓	✓	✓	✓
Ⓜ Mic In/Side Speaker Out				✓



- If you want to install a Side Speaker, you need to retask either the Line in or Mic in jack to be Side Speaker out through the audio driver.
- To enable or configure the audio amplifying function for the Line out jack, please access the HD Audio Manager application.



- When removing the cable connected to a back panel connector, first remove the cable from your device and then remove it from the motherboard.
- When removing the cable, pull it straight out from the connector. Do not rock it side to side to prevent an electrical short inside the cable connector.

## 4-9 Internal Connectors

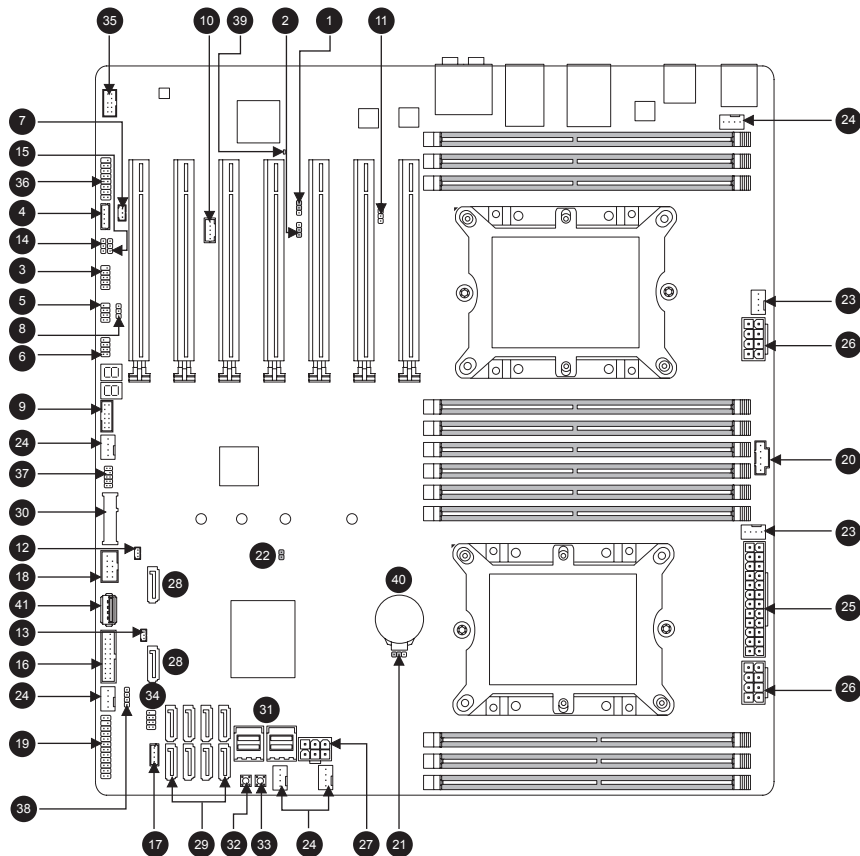

1	BMC_VGA	12	SATA_DOM0	23	CPU_FAN1-2	34	S_SGPIIO
2	BMC_WATCHD	13	SATA_DOM1	24	SYS_FAN1-5	35	F_AUDIO
3	COM	14	VRM_SCL	25	ATX	36	VGA
4	SMB_IPMB	15	VRM_SDA	26	ATX8P_1~2	37	SMB_VMD
5	I_SGPIIO1	16	FUSB30	27	ATX12V 6P	38	SPEAKER
6	I_SGPIIO2	17	VROC	28	S-SATA0-1	39	BMC_LED2
7	WOL	18	FUSB2	29	I-SATA0-7	40	BAT
8	SMB	19	F_PANEL	30	PCIEX4_M2	41	USB 3.0
9	TPM	20	PMBUS	31	U2_1~2		
10	TBT	21	CLR_CMOS	32	PWR_SW		
11	BMC_UART	22	CI	33	RST_SW		



Read the following guidelines before connecting external devices:

- First make sure your devices are compliant with the connectors you wish to connect.
- Before installing the devices, be sure to turn off the devices and your computer. Unplug the power cord from the power outlet to prevent damage to the devices.
- After installing the device and before turning on the computer, make sure the device cable has been securely attached to the connector on the motherboard.

### 1) BMC\_VGA

This jumper allows you to enable or disable the onboard VGA Controller. Set to pins 1-2 to activate VGA feature.



Pin	Definition
1-2	Enable (Default)
2-3	Disable

### 2) BMC\_WATCHD

BMC\_WATCHD controls the Watch Dog function. Watch Dog is a monitor that can reboot the system when a software application hangs. Jumping pins 1-2 will cause Watch Dog to reset the system if an application hangs. Jumping pins 2-3 will generate a non-maskable interrupt signal for the application that hangs. watch Dog must also be enabled in BIOS. The default setting is disable.



Pin	Definition
1-2	Enable
2-3	Disable (Default)

### 3) COM

There is one COM header (COM) on the motherboard. This COM port provide serial communication support. See the table below for pin definitions.



Pin	Definition	Pin	Definition
1	NCCD-	2	NSIN
3	NSOUT	4	NDTR-
5	GND	6	NDSR-
7	NRTS-	8	NCTS-
9	NRI-	10	-

### 4) SMB\_IPMB

A System Management Bus header for IPMI 2.0 is located at SMB\_IPMB. Connect a cable to this header to use the IPMB I2C connection on your system. See the table below for pin definitions.



Pin	Definition
1	SMB_DATA
2	GND
3	SMB_CLK
4	NA

### 5) I\_SGPI01 (For I-SATA0~3)

### 6) I\_SGPI02 (For I-SATA4~7)

A Serial General Purpose Input/Output header (I-SGPIO) is located on the motherboard. This header is used to communicate with the enclosure management chip on the backplane. See the table below for pin definitions



Pin	Definition	Pin	Definition
1	NA	2	-
3	SATA_DATA	4	GND
5	GND	6	SATA_LOAD
7	NA	8	SATA_CLK

### 7) WOL (Wake On Lan)

Wake On Lan by PME, PXE.



Pin	Definition
1	Power (5V)_AUX
2	GND
3	WAKE_EN

### 8) SMB



Pin	Definition
1	SMB_DATA
2	GND
3	SMB_CLK

### 9) TPM (Trusted Platform Module/Port 80 Header)

The TPM header is used to connect a Trusted Platform Module (TPM)/Port 80, which is available from a third-party vendor. A TPM/Port 80 connector is a security device that supports encryption and authentication in hard drives. It allows the motherboard to deny access if the TPM associated with the hard drive is not installed in the system. See the table below for pin definitions.



Pin	Definition	Pin	Definition
1	LPC_IO0	2	Power (3.3V)
3	LPC_IO1	4	-
5	LPC_IO2	6	TPM_CLK
7	LPC_IO3	8	GND
9	LFRAME#	10	NA
11	SERIRQ	12	TPM_RST



## 10) TBT

The TBT header is a general purpose I/O header for a Thunderbolt add-on card.



Pin	Definition
1	FORCE_POWER
2	SCI_EVENT
3	SLP_S3
4	SLP_S5
5	GND

## 11) BMC\_UART



Pin	Definition
1	BMC_UART_TXD
2	GND
3	BMC_UART_RXD
4	Power (5V)

## 12) SATA\_DOM0 (SATA DOM0 Power Header)

## 13) SATA\_DOM1 (SATA DOM1 Power Header)

The Disk-On-Module (DOM) power connectors at SATA\_DOM0 and SATA\_DOM1 provide 5V power to a solid-state DOM storage devices connected to one of the SATA ports. See the table below for pin definitions.



Pin	Definition
1	Power (5V)
2	GND
3	NA

## 14) VRM\_SCL (For VRM SMB\_CLK)

## 15) VRM\_SDA (For VRM SMB\_DATA)

Set this jumper (VRM\_SCL, VRM\_SDA) to jumper to short pins 2-3 Normal (Default) to allow BMC to access VRM controllers. Set this jumper to short pins 1-2 to have VRM code updated by PCH. See the table below for jumper settings.



Pin	Definition
1-2	SMB to PCH
2-3	SMB to BMC

## 16) FUSB30

The motherboard also has a front access USB 3.0 header that supports two USB connections (FUSB30). The onboard headers can be used to provide front side USB access with a cable (not included).

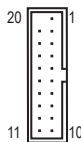

Pin	Definition	Pin	Definition
1	VBUS	11	D2+
2	SSRX1-	12	D2-
3	SSRX1+	13	GND
4	GND	14	SSTX2+
5	SSTX1-	15	SSTX2-
6	SSTX1+	16	GND
7	GND	17	SSRX2+
8	D1-	18	SSRX2-
9	D1+	19	VBUS
10	NC	20	-

## 17) VROC (RAID Key for CPU NVMe SSD)

A RAID\_Key header is located at VROC on the motherboard. RAID key is used to support onboard NVMe connections.



Pin	Definition
1	GND
2	Power (3.3V)_AUX
3	GND
4	PCH RAID KEY

## 18) FUSB2

The motherboard also has a front access USB 2.0 header that supports two USB connections (FUSB2). The onboard headers can be used to provide front side USB access with a cable (not included).



Pin	Definition	Pin	Definition
1	Power (5V)	2	Power (5V)
3	USB DX-	4	USB DY-
5	USB DX+	6	USB DY+
7	GND	8	GND
9	-	10	NC

## 19) F\_PANEL

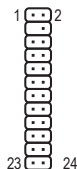

Pin	Definition	Pin	Definition
1	Power LED+	2	5V Standby
3	-	4	ID LED+
5	Power LED-	6	ID LED-
7	HDD LED+	8	System Status LED+
9	HDD LED1	10	System Status LED-
11	Power Button	12	LAN1 Active LED+
13	GND	14	LAN1 Link LED-
15	Reset Button	16	SMBus Data
17	GND	18	SMBus Clock
19	ID Button	20	Case Open
21	GND	22	LAN2 Active LED+
23	NMI Switch	24	LAN2 Link LED-

## 20) PMBUS (Power supply I<sup>2</sup>C Connector)

Power System Management Bus (I<sup>2</sup>C) header at PMBUS monitors the power supply, fan and system temperatures. Refer to the table below for pin definitions.



Pin	Definition
1	SMB_CLK
2	SMB_DATA
3	PSU_ALERT
4	GND
5	Power (3.3V)

## 21) CLR\_CMOS

CLR\_CMOS is used to clear CMOS, which will also clear any passwords. Instead of pins, this jumper consists of contact pads to prevent accidentally clearing the contents of CMOS.



Pin	Definition
1-2	NA (Default)
2-3	Clear CMOS

You may clear the CMOS values by this jumper:

1. First power down the system and unplug the power cord(s).
2. Remove the cover of the chassis to access the motherboard.
3. Remove the onboard battery from the motherboard.
4. Short the CMOS pads with a metal object such as a small screwdriver for at least four seconds.
5. Remove the screwdriver (or shorting device).
6. Put the battery back on the motherboard and replace the cover, reconnect the power cord(s) and power on the system.

## 22) CI

A Chassis Intrusion header is located at CI on the motherboard. Attach the appropriate cable from the chassis to the header to inform you when the chassis is opened.



Pin	Definition
1	Intrusion Input
2	GND

## 23) CPU\_FAN1/CPU\_FAN2

There are two CPU fan headers on the motherboard. These are 4-pin fan headers; pins 1-3 are backward compatible with traditional 3-pin fans. The onboard fan speeds are controlled by Thermal Management (via Hardware Monitoring) in the BIOS. When using Thermal Management setting, please use all 3-pin fans or all 4-pin fans.

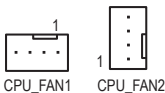

Pin	Definition
1	GND
2	Power (12V)
3	FAN_TACH
4	FAN_PWM

## 24) SYS\_FAN1~5

There are five system fan headers on the motherboard. These are 4-pin fan headers; pins 1-3 are backward compatible with traditional 3-pin fans. The onboard fan speeds are controlled by Thermal Management (via Hardware Monitoring) in the BIOS. When using Thermal Management setting, please use all 3-pin fans or all 4-pin fans.

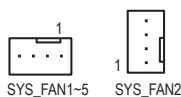

Pin	Definition
1	GND
2	Power (12V)
3	FAN_TACH
4	FAN_PWM

## 25) ATX (2x12 Main Power Connector)

The power connections on the W42G-P08R must be connected to the power supply. The wiring is included with the power supply. The main power supply connector (ATX) meets the ATX SSI EPS 24-pin specification.

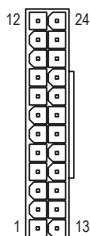

To provide adequate power to your system and to avoid damaging the power supply or the motherboard, be sure to connect all power connectors mentioned above to the power supply. Failure in doing so may void the manufacturer warranty on your power supply and motherboard.

## 26) ATX8P\_1~2 (2x4, 12V Power Connectors)

The power connections on the W42G-P08R must be connected to the power supply. The wiring is included with the power supply.

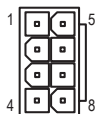

To provide adequate power to your system and to avoid damaging the power supply or the motherboard, be sure to connect all power connectors mentioned above to the power supply. Failure in doing so may void the manufacturer warranty on your power supply and motherboard.

## 27) ATX12V\_6P (2x3, 12V Power Connectors)

6-pin PCI-E Power.

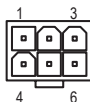

### 28) S-SATA0~1 (SATA 6Gb/s Connectors, Supported by the Intel® PCH)

The C621-WD12 has two S-SATA 3.0 ports (S-SATA0/1) which are supported by the Intel® C621 chipset. S-SATA0/1 can be used with SATA\_DOMs which are Black SATA DOM connectors with power pins built in, and do not require external power cables. SATA\_DOMs are backward-compatible with regular SATA HDDs, need external power cables. All these SATA ports provide serial-link signal connections, which are faster than the connections of Parallel ATA.



### 29) I-SATA0~7 (SATA 6Gb/s Connectors, Supported by the Intel® PCH)

The C621-WD12 has eight I-SATA 3.0 ports (I-SATA0~7) which are supported by the Intel® C621 chipset. All these SATA ports provide serial-link signal connections, which are faster than the connections of Parallel ATA.



### 30) PCIEX4\_M2 (M.2 Socket 3 Connectors)

The PCI-E M.2 connector is for devices such as memory cards, wireless adapters, etc. These devices must conform to the PCI-E M.2 specifications (formerly known as NGFF). Also, the M.2 socket on the motherboard supports PCI-E 3.0 x4 (32 Gb/s) SSD cards(2280 & 22110) and SATA SSD Cards.



### 31) U2\_1~2 (U2 Connector)

This motherboard comes with U.2 connector which support PCIe 3.0 x4 NVM Express storage.



### 32) PWR\_SW (Power Button)

### 33) RST\_SW (Reset Button)

On Board Power Switch & Reset Switch.



### 34) S\_SGPIO (For S-SATA0~1)

A Serial General Purpose Input/Output header (S-SGPIO) is located on the motherboard. This header is used to communicate with the enclosure management chip on the backplane. See the table below for pin definitions.



Pin	Definition	Pin	Definition
1	NA	2	-
3	SATA_DATA	4	GND
5	GND	6	SATA_LOAD
7	NA	8	SATA_CLK

### 35) F\_AUDIO

A 10-pin audio header (F\_AUDIO) located on the motherboard allows you to use the onboard sound chip (ALC1120) for audio functions. Connect an audio cable to the this header to use this feature. See the table below for pin definitions.



### 36) VGA (Supported by the BMC)

The connector support VGA High Dynamic-Range interface from BMC.



Pin	Definition	Pin	Definition
1	VGA-R	2	VGA-G
3	VGA-B	4	NA
5	GND	6	GND
7	GND	8	GND
9	5V	10	GND
11	NA	12	DDC_DATA
13	H_SYNC	14	V_SYNC
15	DDC_CLK	16	-

### 37) SMD\_VMD (NVMe SMBUS Control Header)

SMB\_VMD are management headers for the NVMe PCI-E. Please connect the I2C cable to the connector.



Pin	Definition	Pin	Definition
1	SMB_CPU1_NVME_CLK	2	SMB_CPU1_NVME_DATA
3	GND	4	GND
5	SMB_CPU2_NVME_CLK	6	SMB_CPU2_NVME_DATA
7	GND	8	-
9	SMB_PCH_NVME_CLK	10	SMB_PCH_NVME_DATA

### 38) SPEAKER (Speaker Header)

The Speaker Header (SPEAKER) is used to provide audible indications for various beep codes. See the table below for pin definitions.



Pin	Definition
1	5V
2	NA
3	NA
4	SPK-

### 39) BMC\_LED2 (BMC Heartbeat LED)

BMC\_LED2 is the BMC heartbeat LED. When the LED is blinking yellow, BMC is functioning normally.

State	Description
Off	BMC Normal

### 40) BAT

The battery provides power to keep the values (such as BIOS configurations, date, and time information) in the CMOS when the computer is turned off. Replace the battery when the battery voltage drops to a low level, or the CMOS values may not be accurate or may be lost.

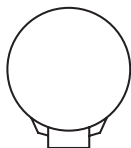

### 41) USB 3.0 (USB 3.1 Gen 1 Connector)

A USB Type A header, USB30V, also provides USB 3.0 support.



## Chapter 5 BIOS Setup

BIOS (Basic Input and Output System) records hardware parameters of the system in the CMOS on the motherboard. Its major functions include conducting the Power-On Self-Test (POST) during system startup, saving system parameters and loading operating system, etc. BIOS includes a BIOS Setup program that allows the user to modify basic system configuration settings or to activate certain system features.

When the power is turned off, the battery on the motherboard supplies the necessary power to the CMOS to keep the configuration values in the CMOS.

To access the BIOS Setup program, press the <Delete> key during the POST when the power is turned on.



- Because BIOS flashing is potentially risky, if you do not encounter problems using the current version of BIOS, it is recommended that you not flash the BIOS. To flash the BIOS, do it with caution. Inadequate BIOS flashing may result in system malfunction.
- It is recommended that you not alter the default settings (unless you need to) to prevent system instability or other unexpected results. Inadequately altering the settings may result in system's failure to boot. If this occurs, try to clear the CMOS values and reset the board to default values. (Refer to the "Restore Defaults" section in this chapter or introductions of the battery/clear CMOS jumper in Chapter 1 for how to clear the CMOS values.)

### 5-1 Startup Screen

The following startup Logo screen will appear when the computer boots.





## 5-2 Main

Once you enter the BIOS Setup program, the Main Menu (as shown below) appears on the screen. Use arrow keys to move among the items and press <Enter> to accept or enter a sub-menu.

### Main Menu Help

The on-screen description of a highlighted setup option is displayed on the right of the Main Menu.

### Submenu Help

While in a submenu, press <F1> to display a help screen (General Help) of function keys available for the menu. Press <Esc> to exit the help screen. Help for each item is in the Item Help block on the right side of the submenu.  
**(Sample BIOS Version: F1)**



- When the system is not stable as usual, select the **Restore Defaults** item to set your system to its defaults.
- The BIOS Setup menus described in this chapter are for reference only and may differ by BIOS version.

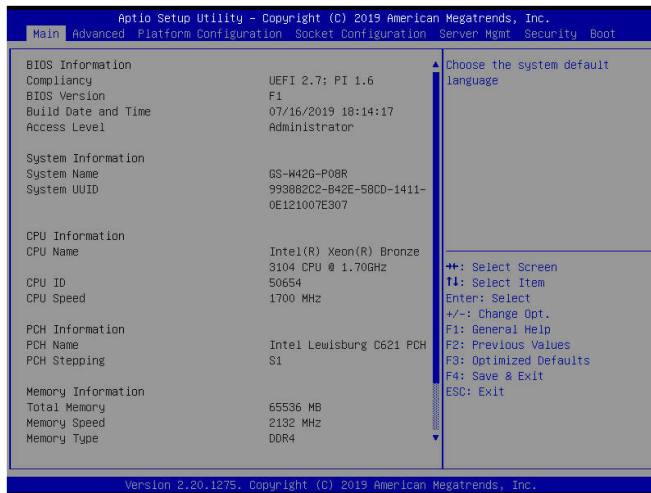

This section provides information on your motherboard model and BIOS version. You can also select the default language used by the BIOS and manually set the system time.

### System Language

Selects the default language used by the BIOS.

### System Date

Sets the system date. The date format is week (read-only), month, date, and year. Use <Enter> to switch between the Month, Date, and Year fields and use the <+> or <-> key to set the desired value.

### System Time

Sets the system time. The time format is hour, minute, and second. For example, 1 p.m. is 13:00:00. Use <Enter> to switch between the Hour, Minute, and Second fields and use the <+> or <-> key to set the desired value.

## 5-3 Advanced

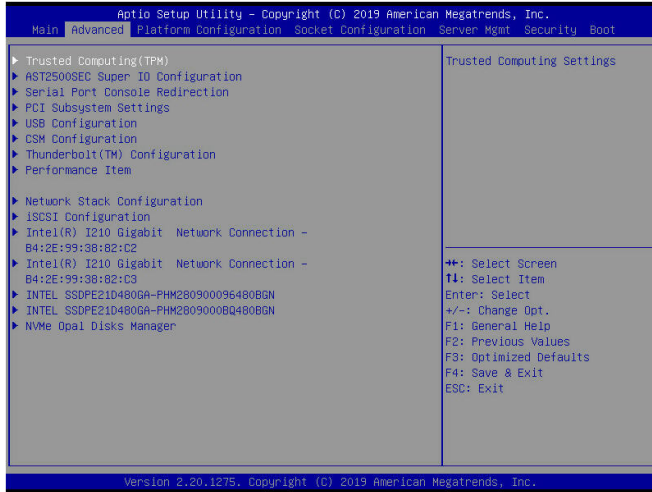

- ▶ **Trusted Computing(TPM)**  
Enables or disables Trusted Platform Module (TPM).
- **Security Device Support**  
Enables or disables BIOS support for security device. OS will not show security device. TCG EFI protocol and INT1A interface will not be available.
- **Disable Block Sid**  
Override to allow SID authentication in TCG storage device.
- ▶ **AST2500SEC Super IO Configuration**  
This section provides information on the super I/O chip and allows you to configure the serial port.
- ▶ **Serial Port Console Redirection**  
This section allows you to enable/disable serial port console redirection for remote server management through a serial port.
- ▶ **PCI Subsystem Settings**
- **Above 4G Decoding**  
Enables or disables 64-bit capable devices to be decoded in above 4 GB address space (only if your system supports 64-bit PCI decoding). Set to **Enabled** if more than one advanced graphics card are installed and their drivers are not able to be launched when entering the operating system (because of the limited 4 GB memory address space).
- **SR-IOV Support**  
If system has SR-IOV capable PCI Express Devices, this option enables/disables Single Root IO Virtualization Support.
- ▶ **USB Configuration**
- **Legacy USB Support**  
Allows USB keyboard/mouse to be used in MS-DOS.
- **USB Mass Storage Driver Support**  
Enables or disables support for USB storage devices.

## ▶ CSM Configuration

### ☞ CSM Support

Enables or disables UEFI CSM (Compatibility Support Module) to support a legacy PC boot process.

- ▶▶ Enabled                    Enables UEFI CSM.
- ▶▶ Disabled                  Disables UEFI CSM and supports UEFI BIOS boot process only.

This item's setting depends on the configuration of **Boot/Boot Mode**.

### ☞ GateA20 Active

- ▶▶ Upon Request            GA20 can be disabled using BIOS services. (Default)
- ▶▶ Always                    GA20 cannot be disabled.

This option is useful when any RT code is executed above 1 MB. This item is configurable only when **CSM Support** is set to **Enabled**.

### ☞ Option ROM Messages

Sets display mode for Option ROM. Options available: Force BIOS, Keep Current.

This item is configurable only when **CSM Support** is set to **Enabled**.

### ☞ INT19 Trap Response

Configures BIOS reaction on INT19 trapping by Option ROM.

- ▶▶ Immediate                The system executes the trap right away.
- ▶▶ Postponed                The system executes the trap during legacy boot.

This item is configurable only when **CSM Support** is set to **Enabled**.

### ☞ HDD Connection Order

Some OS require HDD handles to be adjusted, i.e. OS ins installed onf drive 80h. (Default: Adjust)

### ☞ Boot option filter

Controls Legacy/UEFI ROMs priority.

- ▶▶ Legacy only              Enables legacy option ROM only.
- ▶▶ UEFI only                 Enables UEFI option ROM only.

### ☞ Network

Allows you to select whether to enable the legacy option ROM for the LAN controller.

- ▶▶ Legacy                    Enables legacy option ROM only.
- ▶▶ UEFI                      Enables UEFI option ROM only.

### ☞ Storage

Allows you to select whether to enable the UEFI or legacy option ROM for the storage device controller.

- ▶▶ Legacy                    Enables legacy option ROM only.
- ▶▶ UEFI                      Enables UEFI option ROM only.

### ☞ Video

Allows you to select whether to enable the UEFI or Legacy option ROM for the graphics controller.

- ▶▶ Legacy                    Enables legacy option ROM only.
- ▶▶ UEFI                      Enables UEFI option ROM only.

### ☞ Other PCI devices

Allows you to select whether to enable the UEFI or Legacy option ROM for the PCI device controller other than the LAN, storage device, and graphics controllers.

- ▶▶ Legacy                    Enables legacy option ROM only.
- ▶▶ UEFI                      Enables UEFI option ROM only.

⊙ This item's setting depends on the configuration of **Boot ▶ Boot Mode**.

▶ **Thunderbolt(TM) Configuration**

☞ **TBT Root port Selector**

Allows you to select Thunderbolt AIC location.

▶ **Performance Item**

☞ **PERFORMANCE Table Selector**

Allows you to select performance table.

☞ **Fan Table Selector, SpeedStep (Pstates), Hardware Prefetcher, Adjacent Cache Prefetch, DCU Streamer Prefetcher, Turbo Mode, Uncore Freq Scaling (UFS), Hardware P-States, Autonomous Core C-State, CPU C6 report, Enhanced Halt State (C1E), Package C State, Link L0p Enable, Link L1 Enable, Data Scrambling for DDR4, Patrol Scrub**

These items' settings depend on the configuration of **PERFORMANCE Table Selector**.

▶ **Network Stack Configuration**

☞ **Network Stack**

Disables or enables booting from the network to install a GPT format OS, such as installing the OS from the Windows Deployment Services server.

☞ **Ipv4 PXE Support**

Enables or disables IPv4 PXE Support. This item is configurable only when **Network Stack** is enabled.

☞ **Ipv4 HTTP Support**

Enables or disables HTTP boot support for IPv4. This item is configurable only when **Network Stack** is enabled.

☞ **Ipv6 PXE Support**

Enables or disables IPv6 PXE Support. This item is configurable only when **Network Stack** is enabled.

☞ **Ipv6 HTTP Support**

Enables or disables HTTP boot support for IPv6. This item is configurable only when **Network Stack** is enabled.

☞ **IPSEC Certificate**

Enables or disables the Internet Protocol Security. This item is configurable only when **Network Stack** is enabled.

☞ **PXE boot wait time**

Allows you to configure how long to wait before you can press <Esc> to abort the PXE boot. This item is configurable only when **Network Stack** is enabled.

☞ **Media detect count**

Allows you to set the number of times to check the presence of media. This item is configurable only when **Network Stack** is enabled.

▶ **iSCSI Configuration**

Configure the iSCSI parameters.

▶ **Intel(R) I210 Gigabit Network Connection (Dual\_Lan)**

This sub-menu provides information on LAN configuration and related configuration options.

▶ **Intel(R) I210 Gigabit Network Connection (Dual\_Lan)**

This sub-menu provides information on LAN configuration and related configuration options.

▶ **INTEL SSDPE21D480GA-PHM280900096480BGN**

Display NVME information.

▶ **INTEL SSDPE21D480GA-PHM280900096480BGN**

Display NVME information.

▶ **NVMe Opal Disks Manager**

Manage OPal disks.

## 5-4 Platform Configuration

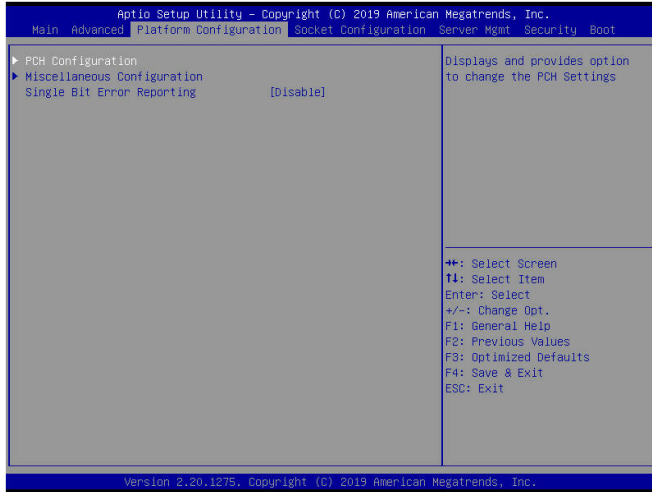

- ▶ **PCH Configuration**

- ▶ **PCH Devices**

- **PCH state after G3**

Allows you to select S0 or S5 for ACPI state after a G3.

- ▶ **PCI Express Configuration**

- **Max Read Request Size**

Allows you to select the PCI Express max read request size.

- ▶ **PCH SATA Configuration (I-SATA0~I-SATA7 Connectors)**

- **SATA Controller**

Enables or disables the integrated SATA controllers.

- **Configure SATA as**

Enables or disables RAID for the SATA controllers integrated in the Chipset or configures the SATA controllers to AHCI mode.

- ▶▶ RAID Enables RAID for the SATA controller.

- ▶▶ AHCI Configures the SATA controllers to AHCI mode. Advanced Host Controller Interface (AHCI) is an interface specification that allows the storage driver to enable advanced Serial ATA features such as Native Command Queuing and hot plug. (Default)

- ▶ **SATA Mode options**

- **SATA HDD Unlock**

Enables or disables hard drive password unlock in the OS.

- **SATA Led locate**

If enabled, LED/SGPIO hardware is attached.

- **Support Aggressive Link Power Management**

Enables or disables the power saving feature, ALPM (Aggressive Link Power Management), for the Chipset SATA controllers.

- ☞ **Load EFI Driver for RAID**  
Allows you to select whether to load EFI driver in RAID mode. If disabled, loads legacy OPROM.
- ☞ **SATA Port 0/1/2/3/4/5/6/7**  
Enables or disables each SATA port.
  
- ▶ **PCH sSATA Configuration (S-SATA0, S-SATA1 Connectors)**
  - ☞ **sSATA Controller**  
Enables or disables the integrated SATA controllers.
  - ☞ **Configure sSATA as**  
Enables or disables RAID for the SATA controllers integrated in the Chipset or configures the SATA controllers to AHCI mode.
    - ▶▶ RAID            Enables RAID for the SATA controller.
    - ▶▶ AHCI            Configures the SATA controllers to AHCI mode. Advanced Host Controller Interface (AHCI) is an interface specification that allows the storage driver to enable advanced Serial ATA features such as Native Command Queuing and hot plug.
  
- ▶ **SATA Mode options**
  - ☞ **SATA HDD Unlock**  
Enables or disables hard drive password unlock in the OS.
  - ☞ **SATA Led locate**  
If enabled, LED/SGPIO hardware is attached.
  - ☞ **Support Aggressive Link Power Management**  
Enables or disables the power saving feature, ALPM (Aggressive Link Power Management), for the Chipset SATA controllers.
  - ☞ **Load EFI Driver for RAID**  
Allows you to select whether to load EFI driver in RAID mode. If disabled, loads legacy OPROM.
  - ☞ **sSATA Port 0/1**  
Enables or disables each SATA port.
  
- ▶ **Miscellaneous Configuration**
  - ☞ **Active Video**  
Allows you to select the active video type. Options are Onboard Device, PCIE Device.
  
  - ☞ **Single Bit Error Reporting**  
Enables or disables Single Bit Error selection.

## 5-5 Socket Configuration

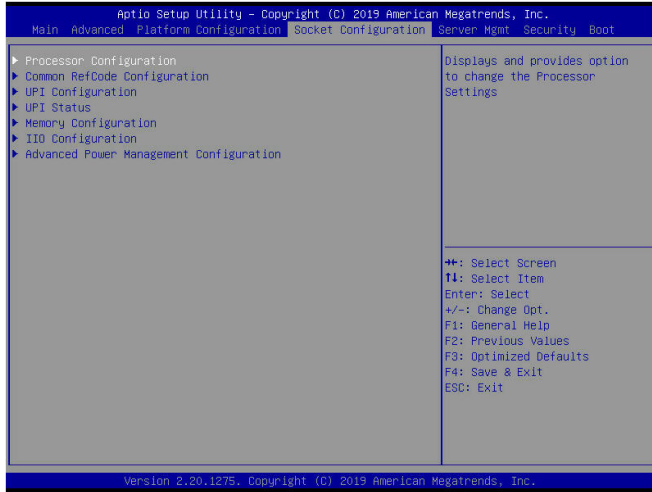

### ▶ Processor Configuration

The sub-menu displays and provides options to change the processor settings.

#### ☞ Hyper-Threading [ALL]

The Hyper Threading Technology allows a single processor to execute two or more separate threads concurrently. When hyper-threading is enabled, multi-threaded software applications can execute their.

#### ☞ VMX

Enables or disables the Vanderpool Technology. This will take effect after rebooting the system.

#### ☞ PPIN Control

Select **Unlock/Enable** to use the Protected-Processor Inventory Number (PPIN) in the system.

#### ☞ Hardware Prefetcher

Select whether to enable the speculative prefetch unit of the processor.

#### ☞ Adjacent Cache Prefetch

When enabled, cache lines are fetched in pairs. When disabled, only the required cache line is fetched.

#### ☞ DCU Streamer Prefetcher

Prefetches the next L1 data line based upon multiple loads in same cache line.

#### ☞ DCU IP Prefetcher

Prefetches the next L1 data line based upon sequential load history.

#### ☞ LLC Prefetch

Enables or disables LLC prefetch on all threads.

#### ☞ Extended APIC

Enables or disables APIC support.

#### ☞ AES-NI

Enables or disables AES-NI support.

## ▶ Common RefCode Configuration

### ☞ MMCFG Base

Selects MMCFG Base.

### ☞ MMIO High Base

Selects MMIO High Base.

### ☞ MMIO High Granularity Size

Selects the allocation size used to assign mmioh resources. Total mmioh space can be up to 32x granularity. Per stack mmioh resource assignments are multiples of the granularity where 1 unit per stack is the default allocation.

### ☞ Isoc Mode

Enables or disables Isoc mode.

### ☞ Numa

Enables or disables Non Uniform Memory Access (NUMA).

## ▶ UPI Configuration

### ▶ UPI General Configuration

#### ☞ Degrade Precedence

Choose Topology Precedence to degrade features if system options are in conflict or choose Feature Precedence to degrade topology if system options are in conflict.

#### ☞ Link Frequency Select

Allows to select the UPI Link Frequency.

#### ☞ Link L0p Enable

Sets to **Enable** will set the `c_10p_en`, **Disable** will reset it. **Auto** decides based on Si compatibility.

#### ☞ Link L1 Enable

Sets to **Enable** will set the `c_11_en`, **Disable** will reset it. **Auto** decides based on Si compatibility.

#### ☞ IO Directory Cache (IODC)

IO Directory Cache (IODC): generate snoops instead of memory lookups, for remote InVIToM (IIO) and/or WCILF (cores), **Auto** sets to WCILF.

#### ☞ SNC

**Auto** supports 1-cluster or 2-clusters depending on IMC interleave. SNC and IMC interleave both **AUTO** will support 1-cluster (XPT/KTI Prefetch enable) 2-IMC way interleave. **Enable** supports Full SNC (2 clusters) and 1-way IMC interleave.

#### ☞ XPT Prefetch

Enables or disables XPT Prefetch.

#### ☞ KTI Prefetch

Enables or disables KTI Prefetch.

#### ☞ Local/Remote Threshold

Selects Local/Remote Threshold.

#### ☞ Stale AtoS

Enables or disables Stale A to S optimization.

#### ☞ LLC dead line alloc

Enables or disables opportunistically fill dead lines in LLC.

### ▶ UPI Status

The sub-menu displays UPI status.

### ▶ Memory Configuration

The sub-menu displays and provides options to change the memory settings.



- ☞ **Enforce POR**  
**Enable** enforces Plan of Record restrictions for DDR4 frequency and voltage programming. **Disable** will disable this feature. **Auto** sets it to the MRC default setting.
- ☞ **PPR Type**  
Selects Post Package Repair Type. **Auto** sets it to the MRC default setting. Options are: Hard PPR, Soft PPR, PPR Disabled
- ☞ **Memory Frequency**  
Maximum memory frequency selections in Mhz. Do not select Reserved.
- ☞ **MRC Promote Warnings**  
Determines if MRC warnings are promoted to system level.
- ☞ **Promote Warnings**  
Determines if warnings are promoted to system level.
- ☞ **Halt on mem Training Error**  
Enables or disables Holt on mem Training Error.
- ☞ **Data Scrambling for NVMDIMM**  
Enables or disables data scrambling for NVMDIMM. **Auto** sets it to the MRC default setting.
- ☞ **Data Scrambling for DDR4**  
Enables or disables data scrambling for DDR4. **Auto** sets it to the MRC default setting.
- ☞ **2x Refresh Enable**  
Enables or disables 2x Refresh.
- ▶ **Memory Topology**  
Displays memory topology with DIMM population information.
- ▶ **Page Policy**
- ☞ **Page Policy**  
Allows you to select Page Policy.
- ▶ **Memory Map**
- ☞ **IMC Interleaving**  
Allows you to select IMC Interleaving.
- ▶ **Memory RAS Configuration**  
Displays and provides option to change the memory RAS settings.
- ☞ **Static Virtual Lockstep Mode**  
Enables or disables Static Virtual Lockstep mode.
- ☞ **Mirror mode**  
Mirror mode will set entire 1LM memory in system to be mirrored, consequently reducing the memory capacity by half. Enables the Mirror mode will disable XPT Prefetch.
- ☞ **Memory Rank Sparing**  
Enables or disables Memory Rank Sparing. This feature is only available on 1LM.
- ☞ **(Single Bit) Correctable Error Threshold**  
Correctable Error Threshold (0x01 - 0x7fff) used for sparing, tagging, and leaky bucket.
- ☞ **Patrol Scrub**  
Enables or disables Patrol Scrub.
- ☞ **Patrol Scrub Interval**  
Selects the number of hours (1-24) required to complete full scrub. A value of zero means auto.
- ▶ **IIO Configuration**  
The sub-menu displays and provides options to change the IIO settings.

- ▶ **Socket0 Configuration**  
Press [Enter] for configuration of advanced items.
- ▶ **Socket1 Configuration**  
Press [Enter] for configuration of advanced items.
- ▶ **IOAT Configuration**  
The sub-menu provides options enable or disable the IIO IOAPIC Stacks 0~5.
- ☞ **Disable TPH**  
Enables or disables TLP Processing Hint disable.
- ☞ **Prioritize TPH**  
Enables or disables Prioritize TLP.
- ☞ **Relaxed Ordering**  
Enables or disables Relaxed Ordering.
- ▶ **Intel® VT for Directed I/O (VT-d)**  
Enables or disables Intel® Virtualization Technology for Directed I/O.
- ▶ **Intel® VMD technology**  
Enables or disables Intel® Volume Management Device (Intel® VMD) technology.
- ☞ **PCI-E Completion Timeout (Global) Disable**  
Enables or disables the Completion Timeout (D:x F:00:B8h B:4) where x is 0-3.
- ☞ **PCIe Max Read Request Size**  
Sets Max Read Request Size in EndPoints.
- ▶ **Advanced Power Management Configuration**  
The sub-menu displays and provides options to change the power management settings.
- ▶ **CPU P State Control**
- ☞ **SpeedStep (Pstates)**  
Enables or disables EIST (P-States).
- ☞ **EIST PSD Function**  
Chooses HW\_ALL/SW\_ALL/SW\_ANY in PSD return.
- ▶ **Turbo Mode**  
Enables or disables processor Turbo Mode (requires EMTTM enabled too).
- ▶ **Hardware PM State Control**
- ☞ **Hardware P-States**
  - ▶▶ Disable      Hardware chooses a P-State based on OS request (Legacy P-States).
  - ▶▶ Native Mode      Hardware chooses a P-State based on OS guidance.
  - ▶▶ Out of Band Mode      Hardware autonomously chooses a P-State (no OS guidance).
  - ▶▶ Native Mode with No Legacy Support      Native mode with no support for older hardware.
- ▶ **CPU C State Control**
- ☞ **Autonomous Core C-State**  
Enables or disables Autonomous Core C-State Control.
- ☞ **CPU C6 report**  
Allows you to determine whether to let the CPU enter C6 mode in system halt state. When enabled, the CPU core frequency and voltage will be reduced during system halt. **Auto** lets the BIOS automatically configure this setting.
- ☞ **Enhanced Halt State (C1E)**  
Enables or disables Intel® CPU Enhanced Halt (C1E) function, a CPU power-saving function in system halt state. When enabled, the CPU core frequency and voltage will be reduced during system halt state to decrease power consumption.

▶ **Package C State Control**

↳ **Package C State**

Configures the state for the C-State package limit. Options are C0/C1 state, C2 state, C6(non Retention) state, C6(Retention) state, No Limit, Auto.

▶ **CPU Thermal Management**

▶ **CPU T State Control**

↳ **Software Controlled T-States**

Enables or disables Software Controlled T-States.

↳ **T-State Throttle Level**

On-Die Thermal Throttling.

▶ **CPU - Advanced PM Tuning**

▶ **Energy Perf BIAS**

↳ **Power Performance Tuning**

Options are: OS Controls EPB and BIOS Controls EPB.

↳ **PECI PCS EPB**

Controls whether PECI has control over EPB. Options are: OS Controls EPB and PECI controls EPB using PCS.

↳ **ENERGY\_PERF\_BIAS\_CFG mode**

Uses input from ENERGY\_PERF\_BIAS\_CONFIG mode selection. Options are: Performance, Balanced Performance, Balanced Power, and Power. This item is configurable only when **Power Performance Tuning** is set to **BIOS Controls EPB**.

## 5-6 Server Mgmt



- ☞ **BMC Support**  
Enables or disables interfaces to communicate with BMC.
- ☞ **Wait For BMC**  
Allows you to determine whether to wait for BMC response for specified time out. In PILOTII, BMC starts at the same time when BIOS starts during AC power ON. It takes around 30 seconds to initialize Host to BMC interfaces.
- ☞ **FRB-2 Timer**  
Enables or disables FRB-2 Timer (POST timer).
- ☞ **FRB-2 Timer timeout**  
Allows you to set FRB-2 Timer Expiration from 3 to 6 minutes. This item is configurable only when **FRB-2 Timer** is set to **Enabled**.
- ☞ **FRB-2 Timer Policy**  
Configures how the system should respond if the FRB-2 Timer expires. This item is configurable only when **FRB-2 Timer** is set to **Enabled**.
- ☞ **OS Watchdog Timer**  
**Enabled** starts a BIOS timer which can only be shut off by Management Software after the OS loads. Helps determine that the OS successfully loaded or follows the OS Boot Watchdog Timer policy.
- ☞ **OS Wtd Timer Timeout**  
Configures the length of the OS Boot Watchdog Timer. Options are: 5 minutes, 10 minutes, 15 minutes, and 20 minutes. This item is configurable only when **OS Watchdog Timer** is set to **Enabled**.
- ☞ **OS Wtd Timer Policy**  
Configures how the system should respond if the OS Boot Watchdog Timer expires. This item is configurable only when **OS Watchdog Timer** is set to **Enabled**.
- ▶ **System Event Log**  
Press [Enter] to change the SEL event log configuration.
- ▶ **View FRU information**  
Press [Enter] to view FRU information.

- ▶ **BMC network configuration**  
Press [Enter] to configure BMC network parameters.
- ▶ **View System Event Log**  
Press [Enter] to view the system event log records.

## 5-7 Security

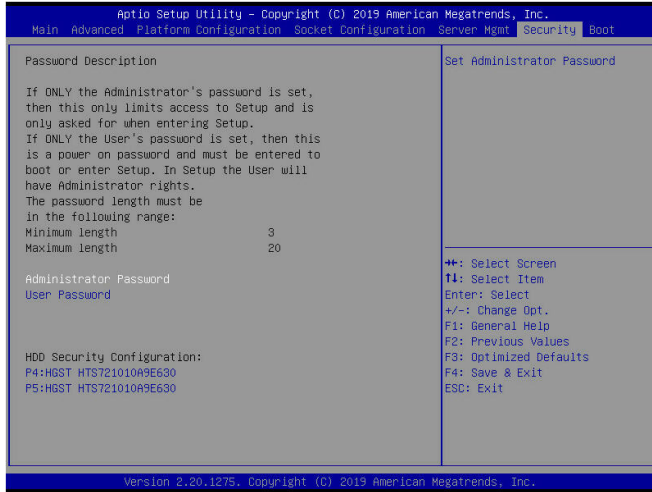

### Administrator Password

Allows you to configure an administrator password. Press <Enter> on this item, type the password, and then press <Enter>. You will be requested to confirm the password. Type the password again and press <Enter>. You must enter the administrator password (or user password) at system startup and when entering BIOS Setup. Differing from the user password, the administrator password allows you to make changes to all BIOS settings.

### User Password

Allows you to configure a user password. Press <Enter> on this item, type the password, and then press <Enter>. You will be requested to confirm the password. Type the password again and press <Enter>. You must enter the administrator password (or user password) at system startup and when entering BIOS Setup. However, the user password only allows you to make changes to certain BIOS settings but not all. To cancel the password, press <Enter> on the password item and when requested for the password, enter the correct one first. When prompted for a new password, press <Enter> without entering any password. Press <Enter> again when prompted to confirm.

NOTE: Before setting the User Password, be sure to set the Administrator Password first.

## 5-8 Boot

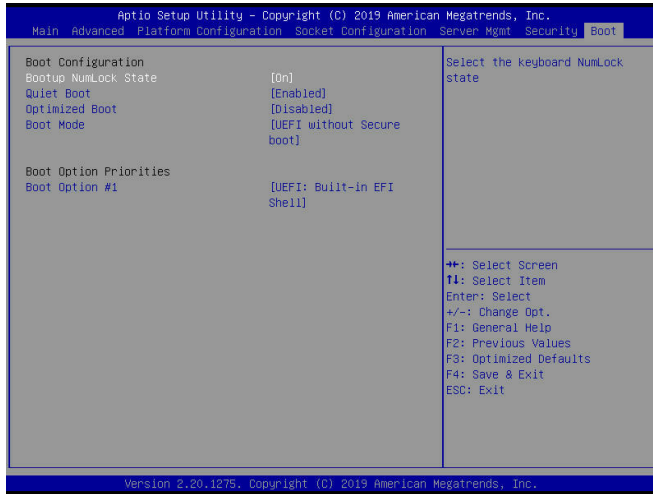

- ☞ **Bootup NumLock State**  
Enables or disables Numlock feature on the numeric keypad of the keyboard after the POST.
- ☞ **Quiet Boot**  
Allows you to determine whether to display the GIGABYTE Logo at system startup.
- ☞ **Optimized Boot**  
Enables or disables Optimized Boot. Enabling Optimized Boot will disable CSM support and disable connecting Network devices to decrease boot time. While disabling Optimized Boot, make sure to restore CSM support option to previous value before enabling Optimized Boot.
- ☞ **Boot Mode**
  - ▶▶ Legacy Only      CSM is enabled, all of option ROMs in legacy.
  - ▶▶ UEFI without Secure boot      CSM is enabled, most of option ROMs in UEFI.
  - ▶▶ UEFI with Secure boot      CSM is disabled, all of the option ROMs in UEFI. Secure Boot is showed and selected by customer.
- ☞ **Boot Option**  
Specifies the boot order for a specific device type, such as hard drives, optical drives, floppy disk drives, and devices that support Boot from LAN function, etc. Press <Enter> on this item to enter the submenu that presents the devices of the same type that are connected. This item is present only if at least one device for this type is installed.

## 5-9 Save & Exit

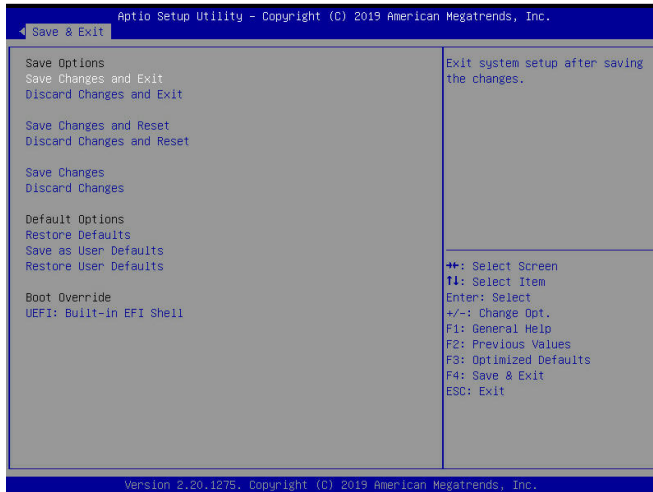

- ☞ **Save Changes and Exit**  
Press <Enter> on this item and select **Yes**. This saves the changes to the CMOS and exits the BIOS Setup program. Select **No** or press <Esc> to return to the BIOS Setup Main Menu.
- ☞ **Discard Changes and Exit**  
Press <Enter> on this item and select **Yes**. This exits the BIOS Setup without saving the changes made in BIOS Setup to the CMOS. Select **No** or press <Esc> to return to the BIOS Setup Main Menu.
- ☞ **Save Changes and Reset**  
Press <Enter> on this item and select **Yes** to save the changes to the CMOS. Select **No** or press <Esc> to return to the BIOS Setup Main Menu. Reboot the system after saving the changes.
- ☞ **Discard Changes and Reset**  
Press <Enter> on this item and select **Yes** to cancel the BIOS changes. Select **No** or press <Esc> to return to the BIOS Setup Main Menu. Reboot the system without saving any changes.
- ☞ **Save Changes**  
Press <Enter> on this item and select **Yes** to save the changes to the CMOS. Select **No** or press <Esc> to return to the BIOS Setup Main Menu.
- ☞ **Discard Changes**  
Press <Enter> on this item and select **Yes** to cancel the BIOS changes. Select **No** or press <Esc> to return to the BIOS Setup Main Menu.
- ☞ **Restore Defaults**  
Press <Enter> on this item and select **Yes** to load the BIOS factory default settings. The BIOS default settings help the system to operate in optimum state. Always load the Optimized defaults after updating the BIOS or after clearing the CMOS values.
- ☞ **Save as User Defaults**  
Save to current BIOS settings as user-defined default settings.
- ☞ **Restore User Defaults**  
Load the user-define default settings for all BIOS options.
- ☞ **Boot Override**  
Allows you to select a device to boot immediately. Press <Enter> on the device you select and select **Yes** to confirm. Your system will restart automatically and boot from that device.



# Chapter 6 BMC Web

You can use the IP from BIOS Setup Manu to connect to BMC Web UI. For example, <https://10.1.5.46>

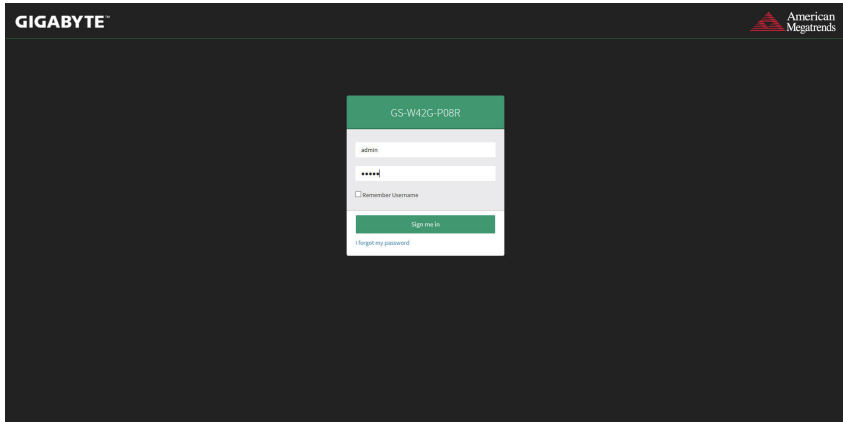

After entering the IP address into web browser, you can enter your username and password (Default Account: **admin** Default Password: **admin**) to enter the Web UI.

## Dashboard

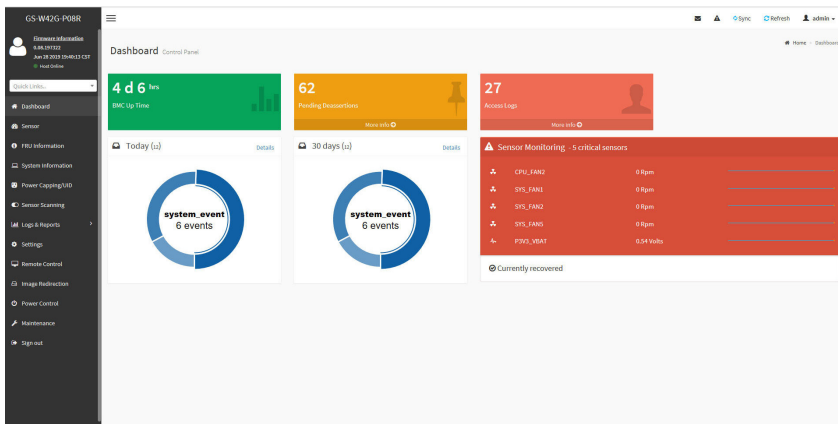

This page shows the summary monitoring information of the board.

## Sensor

**Critical Sensors (5)**

- CPU\_FAN2
- FAN1\_VBAT
- SYS\_FAN1
- SYS\_FAN2
- SYS\_FAN3

**Discrete Sensor States (22)**

Sensor Name	State
BMC Watchdog	
GATEB	
CPU ERB2	
CPU Proc Status	
FP MM Diag Vt	
HDD Status	Present
HDD1 Status	Present
HDD2 Status	
HDD3 Status	Present
HDD4 Status	Present
HDD5 Status	Present

On this page, details for all the available sensors e.g. Name, Type, Status, Current Reading and Behavior are displayed. The sensor readings are available for Temperature, Fan, Watchdog and Voltage Sensors as well as for supported Discrete Sensors. This page will refresh automatically with the latest data retrieved from the database. Please note that there may be some delay in retrieving this live data. Sensors are organized by their Type and State (Critical, Discrete, Normal and Disabled).

### Sensor Details

Click on any sensor to view more information about it. For each sensor, thresholds (if supported) and graphical representation of all associated events (read-only) are shown. If you select a sensor from the Normal Sensors sections, a Live Widget is also displayed showing its behavior over time.

## FRU Information

**Available FRU Devices**

FRU Device ID:

FRU Device Name: B0M5\_FRU

**Chassis Information**

Chassis Information Area Format Version	1
Chassis Type	Unspecified
Chassis Part Number	NA
Chassis Serial Number	NA
Chassis Extra	

**Board Information**

Board Information Area Format Version	1
Language	0
Manufacture Date Time	Fri Jun 28 11:40:00 2019
Board Manufacturer	GIGABYTE TECHNOLOGY CO.,LTD
Board Product Name	GIG1-W012
Board Serial Number	V18105
Board Part Number	M18107
FRU File ID	
Board Extra	

**Product Information**

Product Information Area Format Version	1
Language	0
Product Manufacturer	GIGABYTE TECHNOLOGY CO.,LTD
Product Name	W012-P08R
Product Part Number	M18107
Product Version	008
Product Serial Number	V18105
Asset Tag	-----
FRU File ID	
Product Extra	

This page displays Basic Information, Chassis Information, Board Information, and Product Information for the BMC's FRU devices.

### FRU Device ID

Select a FRU Device ID from the drop-down list to view the details of that device.

### FRU Device Name

The device name of the selected FRU will be displayed.

## System Information

The screenshot shows the 'System Information' page in the iDRAC interface. The left sidebar contains navigation options: Dashboard, Sensor, FPU Information, System Information (selected), Power Capping/UID, Sensor Scanning, Logs & Reports, Settings, Remote Control, Image Redirection, Power Control, Maintenance, and Sign-out. The main content area is titled 'System Information' and displays hardware details in three sections:

- BIOS:**

Product	W032
Vendor	AMI
Version	F1
- CPU:**

Index	1
Core	6
Frequency	1700
Brand	INTEL(R) Xeon(R) Bronze 3104 CPU @ 1.70GHz
- DIMM:**

Index	1
Frequency	2132
Size	0
Manufacturer	Micron
Serial Number	88F5D047
Part Number	T2AG59K7L2-20502
Channel	D

This page displays BIOS, CPU, DIMM and Backplane Firmware information.

## Power Capping/UID

The screenshot shows the 'Power Setting' page in the iDRAC interface. The left sidebar is identical to the previous screenshot. The main content area is titled 'Power Setting' and contains the 'Power Capping' configuration section:

- UID LED:**  Off
- Status:**  Disabled
- Current Power:** 8 W
- Power Limit:**
- After Failed:**  Event Log  Off

A 'Save' button is located below the configuration fields. To the right of the configuration is a graph showing power consumption over time. The x-axis is labeled 'Time (HH:MM:SS)' and ranges from 10:25:04 to 10:25:48. The y-axis represents power in Watts (W). A single data point is visible at 10:25:04, showing a power consumption of approximately 8 W.

**NOTE:** It is recommended power capping value does not below minimum, it might cause power capping action fail.

This page displays Unit Identification (UID) Button and Power Capping function. When you enable UID, the UID LED on the front panel glows blue. User can set Power Limit to limit the power consumed by servers.

Note: It is recommended that power limit should not be set below minimum. The action after failed also should be set carefully.

## Sensor Scanning

This page displays sensor scanning is disabled or enabled.

## IPMI Event Log

This page displays the list of events incurred by the different sensors on this device. Click on a record to see the details of that entry. With your cursor, hover over the graph to view the number of events by date. You can also select between BMC or Client Time zone. You can use the date range, sensor type, or sensor name filter options to view those specific events. Click **Clear Event Logs** option to delete all existing records for all sensors. Click **Download Event Logs** option to download the logs in a text file format.

## System Log

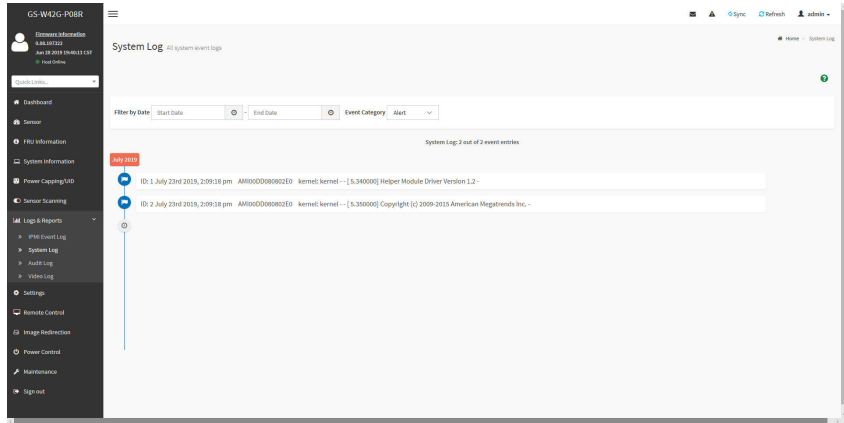

This page displays logs of system events for this device (if the options have been configured).

**Note:** Logs must be configured under "Settings/Log Settings/Advanced Log Settings" to display any entries. Filtering options are also available for this and all logs in this section.

## Audit Log

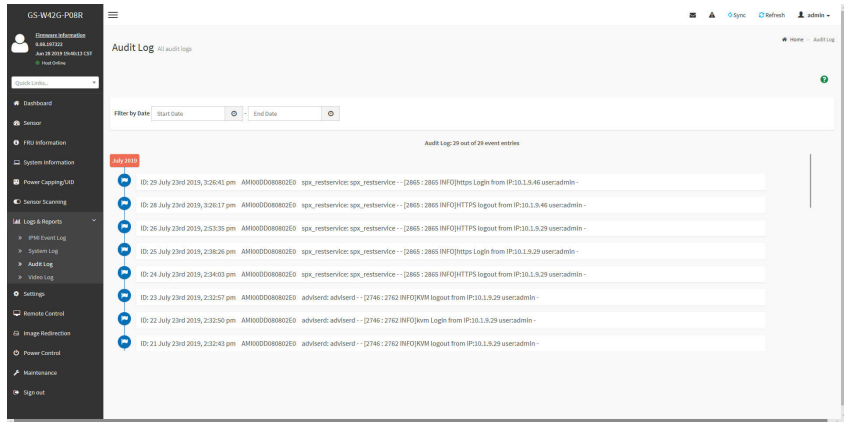

This page displays audit events for this device (if configured).

**Note:** For configuration, go to "Settings/Log Settings/Advanced Log Settings."

## Video Log

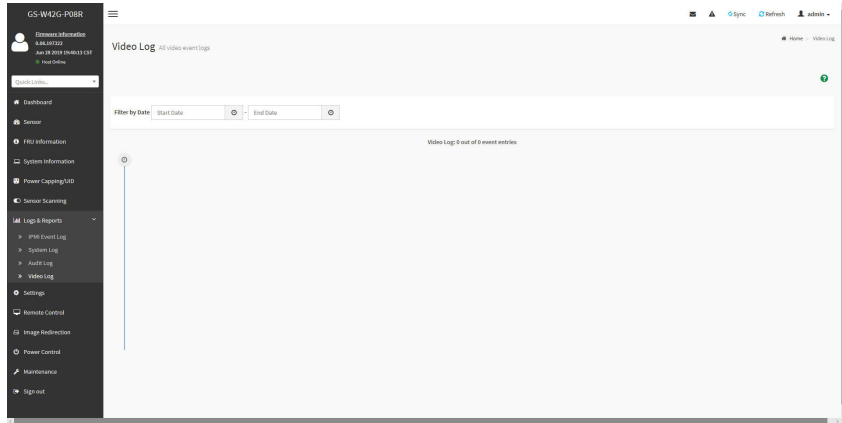

This page displays available recorded video files (if the options have been configured).

**Note:** For configuration, go to "Settings/Video Recording/Auto Video Settings/Video Trigger Settings."

## Settings

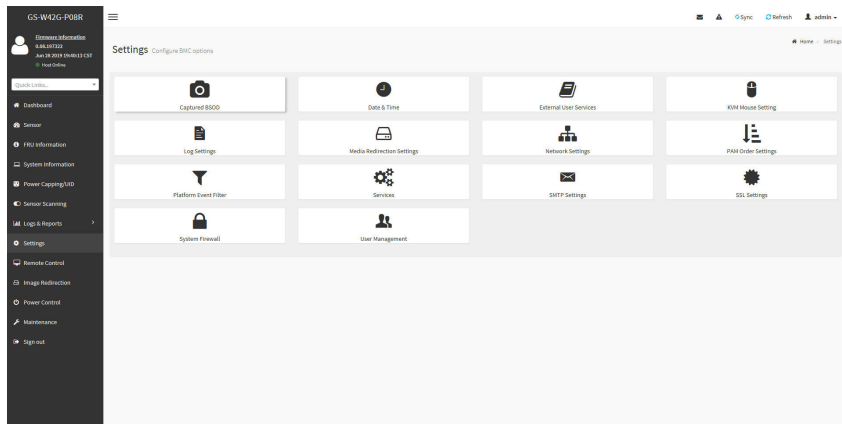

This page allows you to configure BMC options. The options are: Captured BSOD, Date & Time, External User Services, KVM Mouse Setting, Log Settings, Media Redirection Settings, Network Settings, PAM Order Settings, Platform Event Filter, Services, SMTP Settings, SSL Settings, System Firewall, User Management, and Video Recording.

## Remote Control

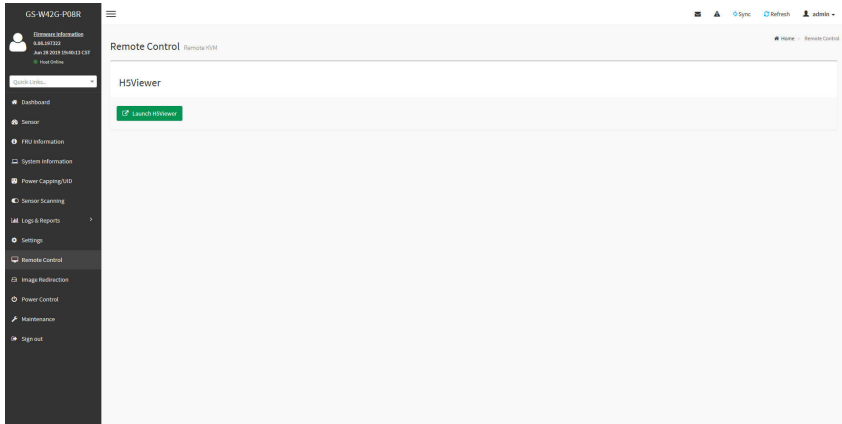

On this page, you can remote control your host system on BIOS Setup or Operating System.

## Remote Control- Example (BIOS Setup menu)

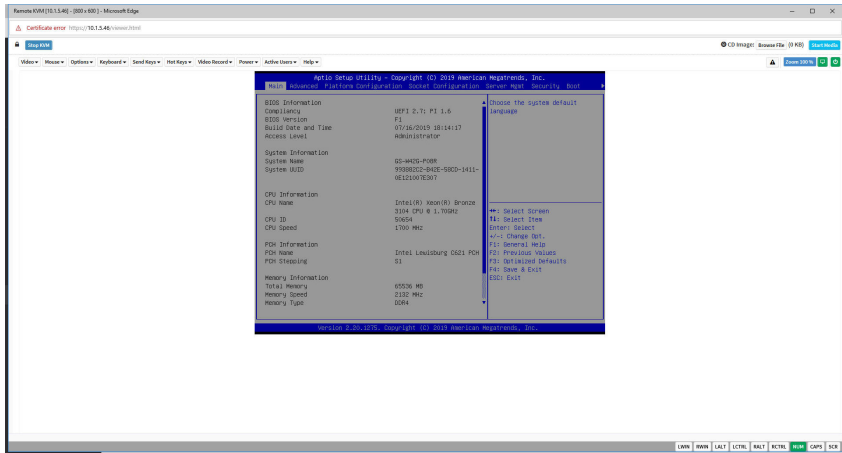

This page shows the BIOS Setup settings.

## Power Control

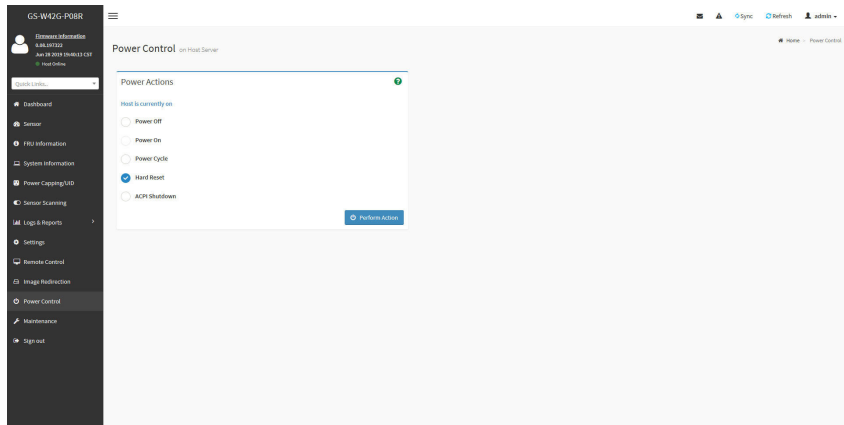

On this page, you can remote control the power of your host system.

## Maintenance

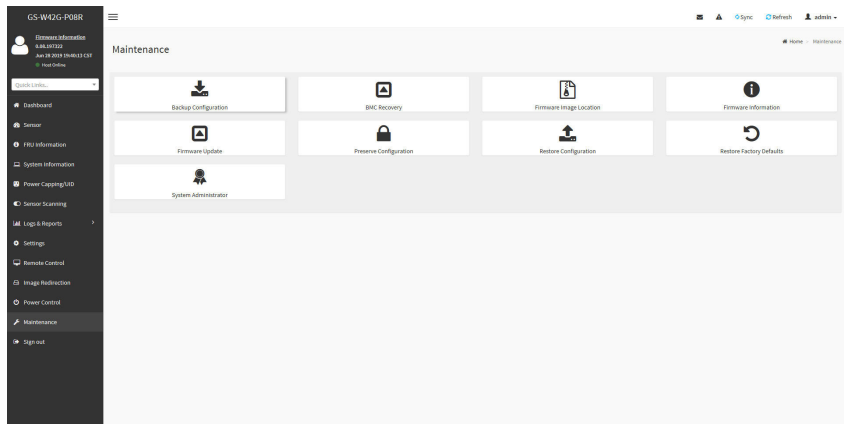

This page allows you to configure BMC options. The options are Backup Configuration, BMC Recovery, Firmware Image Location, Firmware Information, Firmware Update, Preserve Configuration, Restore Configuration, Restore Factory Defaults, and System Administrator.



## Image Redirection

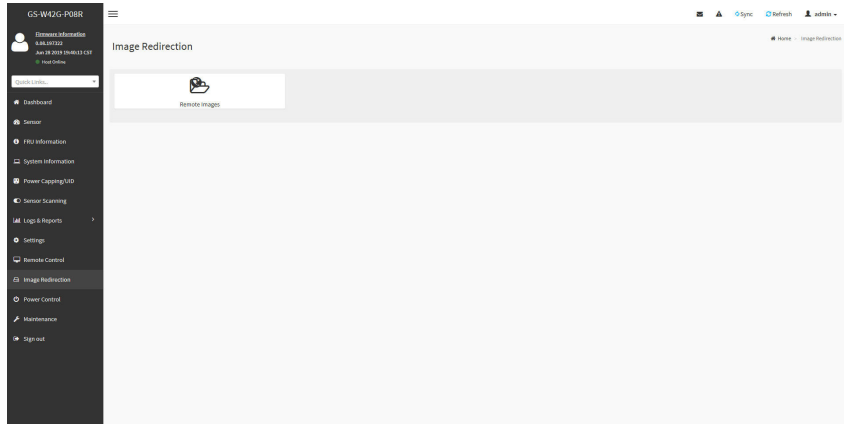

The displayed table shows remote images available to the BMC. You can start redirection or clear the images from here. Up to 4 images can be added for each image type, depending on your configuration.

## Regulatory Notices/管理声明

### WEEE Symbol Statement



The symbol shown below is on the product or on its packaging, which indicates that this product must not be disposed of with other waste. Instead, the device should be taken to the waste collection centers for activation of the treatment, collection, recycling and disposal procedure. The separate collection and recycling of your waste equipment at the time of disposal will help to conserve natural resources and ensure that it is recycled in a manner that protects human health and the environment. For more information about where you can drop off your waste equipment for recycling, please contact your local government office, your household waste disposal service or where you purchased the product for details of environmentally safe recycling.

- When your electrical or electronic equipment is no longer useful to you, "take it back" to your local or regional waste collection administration for recycling.
- If you need further assistance in recycling, reusing in your "end of life" product, you may contact us at the Customer Care number listed in your product's user's manual and we will be glad to help you with your effort.



### Battery Warning:

Incorrectly installing a battery or using incompatible battery may increase the risk of fire explosion. Replace the battery only with the same or equivalent type.

- Do not disassemble, crush, puncture batteries.
- Do not store or place your battery pack next to or in a heat source such as a fire, heat generating appliance, can or exhaust vent. Heating battery cells to temperatures above 65°C (149°F) can cause explosion or fire.
- Do not attempt to open or service batteries. Do not dispose of batteries in a fire or with household waste.



### 电池警告:

电池安装不当或使用不兼容的电池会增加火灾爆炸风险。更换电池时，只可使用相同或同等类型的电池。

- 请勿拆解、挤压、刺破电池。
- 请勿将电池存放或放置在热源中或旁边，如火源、产生热的设备、罐体或排气口。电池温度升至65°C (149°F)以上可能导致爆炸或火灾。
- 请勿尝试打开或维修电池。电池废弃时，请勿投入火中或者作为家庭废弃物进行处理。

### Ambient Operation

This equipment should not be operated above an ambient operation temperature of 35 degrees centigrade.

### Restricted Access Location

This server is intended for installation only in restricted access locations where.

- Access can only be gained by SERVICE PERSONS who have been instructed about the reasons for the restrictions applied to the location and about any precautions that shall be taken.
- Access is through the use of a TOOL or lock and key, or other means of security, and is controlled by the authority responsible for the location.



- ⚡ The system may have more than one power supply cable. To reduce the risk of electrical shock, a trained service technician may need to disconnect all
- ⚡ power supply cables before servicing the system.

### Power Supply

**CAUTION:** The power supplies in your system may produce high voltages and energy hazards, which can cause bodily harms. Unless you are instructed otherwise, only trained service technicians are authorized to remove the covers and access any of the components inside the system.

### Reliable Earthing

**CAUTION:** Do not connect or disconnect any cables or perform installation, maintenance, or reconfiguration of this server during an electrical storm.

**CAUTION:** Connect all power cords to a properly wired and grounded electrical outlet.

### **Hazardous FAN**

**CAUTION:** This server contains hazardous moving fan blades, keep fingers and other bodyparts away. Disconnect all power supply cords before servicing. Connect power supply cord only after all the covers are properly installed.

### **Hazardous Energy**



**CAUTION:** This server contains hazardous energy over 240VA on the backplane. To prevent accidental short circuit, always insert the HDD trays after servicing.

### **Rack Mount Instructions**

The following or similar rack-mount instructions are included with the installation instructions:

- A) Elevated Operating Ambient - If installed in a closed or multi-unit rack assembly, the operating ambient temperature of the rack environment may be greater than room ambient. Therefore, consideration should be given to installing the equipment in an environment compatible with the maximum ambient temperature (T<sub>ma</sub>) specified by the manufacturer.
- B) Reduced Air Flow - Installation of the equipment in a rack should be such that the amount of air flow required for safe operation of the equipment is not compromised.
- C) Mechanical Loading - Mounting of the equipment in the rack should be such that a hazardous condition is not achieved due to uneven mechanical loading.
- D) Circuit Overloading - Consideration should be given to the connection of the equipment to the supply circuit and the effect that overloading of the circuits might have on overcurrent protection and supply wiring. Appropriate consideration of equipment nameplate ratings should be used when addressing this concern.
- E) Reliable Earthing - Reliable earthing of rack-mounted equipment should be maintained. Particular attention should be given to supply connections other than direct connections to the branch circuit (e.g. use of power strips).

***Disconnect 2 power supply cords before servicing***



**CAUTION:** Slider/rail mounted equipment is not to be used as a shelf or a work space.

**For more information, visit our website at: <https://www.gigabyte.com>**

关于符合中国《电器电子产品有害物质限制使用管理办法》的声明

Management Methods for the Restriction of the Use of Hazardous Substances from Electrical and Electronic Products



产品中有毒物质的名称及含量 (Name and Concentration of Toxic Substances)

部件名称(Parts)	有毒有害物质或元素 (Toxic substances or elements)					
	铅(Pb)	汞(Hg)	镉(Cd)	六价铬 (Cr <sup>VI</sup> )	多溴联苯(PBB)	多溴二苯醚 (PBDE)
电路板 PCB	○	○	○	○	○	○
结构件及散热器 Mechanical parts and Heat Sink	×	○	○	○	○	○
电源 Power Supply	×	○	○	○	○	○
芯片及其他主动零件 Chip and other Active component	×	○	○	○	○	○
连接器 Connectors	×	○	○	○	○	○
被动电子器件 Passive Components	×	○	○	○	○	○
线材 Cables	○	○	○	○	○	○
焊接金属 Soldering metal	○	○	○	○	○	○
助焊剂, 散热膏, 标签及其他耗材 Flux, Solder Paste, Label and other Consumable Materials	○	○	○	○	○	○

本表格依据SJ/T 11364 的规定编制。(This table is based on SJ/T 11364.)

○：表示该有害物质在该部件所有均质材料中的含量均在 GB/T 26572 规定的限量要求以下。  
(Indicates that this toxic or hazardous substances contained in all of the homogeneous materials for this part is below the limit requirement specified in GB/T 26572.)

×：表示该有害物质至少在该部件的某一均质材料中的含量超出 GB/T 26572 规定的限量要求。  
但所有部件都符合欧盟 RoHS 要求。  
(Indicates that this toxic or hazardous substances contained in at least one of the homogeneous materials used for this part is above the limit requirement specified in GB/T 26572. All parts comply with EU RoHS Directive.)  
(企业可在此处, 根据实际情况对上表中打“×”的技术原因进行进一步说明。)  
(According to the "X" in this Table, Please note the Technical reasons or Instructions here.)









## Contact Us

---

### GIGA-BYTE TECHNOLOGY CO., LTD.

Address: No.6, Baoqiang Rd., Xindian Dist., New Taipei City 231, Taiwan

TEL: +886-2-8912-4000, FAX: +886-2-8912-4005

Tech. and Non-Tech. Support (Sales/Marketing) : <https://esupport.gigabyte.com>

WEB address (English): <https://www.gigabyte.com>

WEB address (Chinese): <https://www.gigabyte.com/tw>

---

- **GIGABYTE eSupport**

To submit a technical or non-technical (Sales/Marketing) question, please link to:  
<https://esupport.gigabyte.com>

