

GA-7PTSH

Dual LGA2011 sockets motherboard for Intel® E5-2600 series processors

User's Manual

Rev. 1001

Copyright

© 2013 GIGA-BYTE TECHNOLOGY CO., LTD. All rights reserved.

The trademarks mentioned in this manual are legally registered to their respective owners.

Disclaimer

Information in this manual is protected by copyright laws and is the property of GIGABYTE.

Changes to the specifications and features in this manual may be made by GIGABYTE without prior notice. No part of this manual may be reproduced, copied, translated, transmitted, or published in any form or by any means without GIGABYTE's prior written permission.

Documentation Classifications

In order to assist in the use of this product, GIGABYTE provides the following types of documentations:

- For detailed product information, carefully read the User's Manual.

For product-related information, check on our website at:

<http://www.gigabyte.com>

Table of Contents

Box Contents	5
GA-7PTSH Motherboard Layout	6
Chapter 1 Hardware Installation	8
1-1 Installation Precautions	8
1-2 Product Specifications	9
1-3 Installing the CPU	11
1-3-1 Installing the CPU	11
1-4 Installing the Memory	13
1-4-1 Four Channel Memory Configuration	13
1-4-2 Installing a Memory	14
1-4-3 DIMM Population Table	14
1-5 Back Panel Connectors	15
1-6 Internal Connectors	17
Chapter 2 BIOS Setup	29
2-1 The Main Menu	31
2-2 Advanced Menu	34
2-2-1 PCI Subsystem Settings	35
2-2-1-1 PCI Express Settings	37
2-2-2 Runtime Error Logging	39
2-2-3 CPU Configuration	40
2-2-3-1 CPU Power Management Configuration	43
2-2-4 Intel TXT (LT-SX) Configuration	45
2-2-5 USB Configuration	46
2-2-6 SATA Configuration	47
2-2-7 SAS Configuration	49
2-2-8 Info Report Configuration	50
2-2-9 Super IO Configuration	51
2-2-10 Serial Port Console Redirection	53
2-2-11 Network Stack	56
2-2-12 iSCSI Configuration	57
2-2-13 Intel (R) I350 Gigabit Network Connection	58
2-3 Chipset Menu	60
2-3-1 North Bridge	61
2-3-1-1 IOH Configuration	64
2-3-1-2 QPI Configuration	66
2-3-1-3 DIMM Information	67
2-3-2 South Bridge Configuration	68

2-3-3	Intel ME Subsystem.....	70
2-4	Security Menu	71
2-5	Server Management Menu.....	72
2-5-1	BMC LAN Configuration	73
2-5-2	BMC Function.....	74
2-5-3	View FRU Information	75
2-5-4	System Event Log	76
2-6	Boot Menu.....	77
2-6-1	CSM16 Parameters	79
2-6-2	CSM Parameters	80
2-7	Exit Menu	81
2-8	BIOS Beep Codes.....	82
2-9	BIOS Recovery Instruction.....	83

Box Contents

- Motherboard
- Driver CD
- Two SATA cables

- The box contents above are for reference only and the actual items shall depend on the product package you obtain. The box contents are subject to change without notice.
- The motherboard image is for reference only.

GA-7PTSH Motherboard Layout

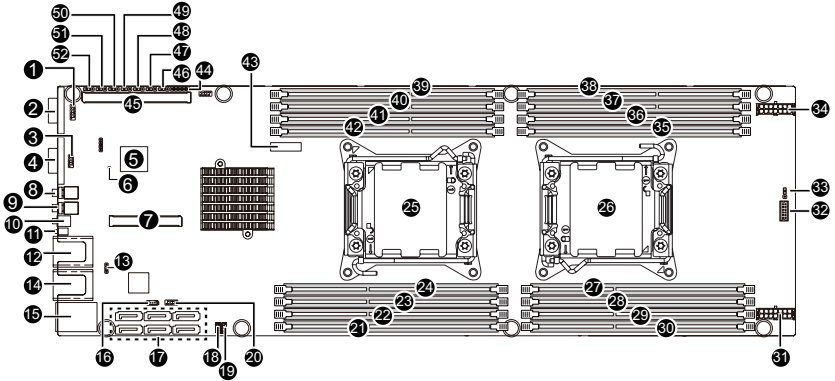

Item	Code	Description
1	FP_VGA1	Front VGA header
2	VGA1	Rear VGA port
3	COM2	Serial port cable header
4	COM1	Serial port
5	U47	ASPEED 2300 BMC chipset
6	BMC_LED1	BMC readiness LED
7	PCIE_2	PCI-E slot 2 (x8 slot/Proprietary/Running at x8)
8	PWR_SW	Power switch button
9	ID_SW1	ID switch button
10	NMI_BMCRST	BMC Reset button (top)/NMI button (bottom)
11	SATAUS_LED	System status LED
12	LAN1	LAN1 port
13	LAN_LED	LAN1 port and LAN2 port active LED header
14	LAN2	LAN2 port
15	MLAN1	BMC Management LAN port (top) / USB ports (bottom)
16	SATA_SGPIO	SATA SGPIO header
17	SATA0/1/2/3/4/5	SATA 6Gb/s connectors
18	IPMB1	IPMB connector
19	RAID_KEY1	Intel RAID Selection connector(Optional)
20	USB1	USB 2.0 header
21	DDR3_P0_A0	Channel 1 slot 0 (for primary CPU)
22	DDR3_P0_A1	Channel 1 slot 1 (for primary CPU)
23	DDR3_P0_B0	Channel 2 slot 0 (for primary CPU)
24	DDR3_P0_B1	Channel 2 slot 1 (for primary CPU)
25	CPU0	Intel LGA2011 socket (Primary CPU)
26	CPU1	Intel LGA2011 socket (Secondary CPU)
27	DDR3_P1_H1	Channel 4 slot 1 (for secondary CPU)
28	DDR3_P1_H0	Channel 4 slot 0 (for secondary CPU)
29	DDR3_P1_G1	Channel 3 slot 1 (for secondary CPU)

30	DDR3_P1_G0	Channel 3 slot 0 (for secondary CPU)
31	SSI_2X9P2	18 pin power connector (for secondary CPU)
32	F_PANEL	Front panel header
33	ACK_SEL	4 Nodes System and Rack System switch jumper
34	SSI_2X9P1	18 pin power connector (for primary CPU)
35	DDR3_P1_F1	Channel 2 slot 1 (for secondary CPU)
36	DDR3_P1_F0	Channel 2 slot 0 (for secondary CPU)
37	DDR3_P1_E1	Channel 1 slot 1 (for secondary CPU)
38	DDR3_P1_E0	Channel 1 slot 0 (for secondary CPU)
39	DDR3_P0_C0	Channel 3 slot 0 (for primary CPU)
40	DDR3_P0_C1	Channel 3 slot 1 (for primary CPU)
41	DDR3_P0_D0	Channel 4 slot 0 (for primary CPU)
42	DDR3_P0_D1	Channel 4 slot 1 (for primary CPU)
43	BAT1	Battery socket
44	PWR_DET	PMBus header
45	PCIE_1	PCI-E slot 1 (x16 slot/Proprietary/Running at x16)
46	BIOS_RVCR1	BIOS recovery jumper
47	SSB_ME1	ME Recovery jumper
48	PASSWORD1	Clearing supervisor password jumper
49	CLR_CMOS1	Clear CMOS jumper
50	BIOS_WP1	BIOS Write Protect jumper
51	FLASH_DP1	Flash descriptor security jumper
52	BMC_FRB1	Force to Stop FRB Timer jumper









Chapter 1 Hardware Installation

1-1 Installation Precautions

The motherboard contains numerous delicate electronic circuits and components which can become damaged as a result of electrostatic discharge (ESD). Prior to installation, carefully read the user's manual and follow these procedures:

- Prior to installation, do not remove or break motherboard S/N (Serial Number) sticker or warranty sticker provided by your dealer. These stickers are required for warranty validation.
- Always remove the AC power by unplugging the power cord from the power outlet before installing or removing the motherboard or other hardware components.
- When connecting hardware components to the internal connectors on the motherboard, make sure they are connected tightly and securely.
- When handling the motherboard, avoid touching any metal leads or connectors.
- It is best to wear an electrostatic discharge (ESD) wrist strap when handling electronic components such as a motherboard, CPU or memory. If you do not have an ESD wrist strap, keep your hands dry and first touch a metal object to eliminate static electricity.
- Prior to installing the motherboard, please have it on top of an antistatic pad or within an electrostatic shielding container.
- Before unplugging the power supply cable from the motherboard, make sure the power supply has been turned off.
- Before turning on the power, make sure the power supply voltage has been set according to the local voltage standard.
- Before using the product, please verify that all cables and power connectors of your hardware components are connected.
- To prevent damage to the motherboard, do not allow screws to come in contact with the motherboard circuit or its components.
- Make sure there are no leftover screws or metal components placed on the motherboard or within the computer casing.
- Do not place the computer system on an uneven surface.
- Do not place the computer system in a high-temperature environment.
- Turning on the computer power during the installation process can lead to damage to system components as well as physical harm to the user.
- If you are uncertain about any installation steps or have a problem related to the use of the product, please consult a certified computer technician.

1-2 Product Specifications

	CPU	<ul style="list-style-type: none"> ◆ Support for Intel® Xeon® E5-2600 series processors in the LGA2011 package ◆ L3 cache varies with CPU ◆ Supports QuickPath Interconnect up to 8GT/s ◆ Enhanced Intel SpeedStep Technology (EIST) ◆ Support Intel Virtualization Technology (VT)
	Chipset	<ul style="list-style-type: none"> ◆ Intel® C602 (Patsburg-A) Chipset
	Memory	<ul style="list-style-type: none"> ◆ 16 x 1.35V/1.5V DDR3 DIMM sockets supporting up to 128GB (UDIMM) and 256GB (RDIMM) of system memory ◆ 16 x 1.35V/1.5V DDR3 LRDIMM sockets supporting up to 512GB of system memory ◆ Four channel memory architecture ◆ Support for 800/1066/1333/1600 memory modules ◆ Support for ECC RDIMM/ UDIMM/ LRDIMM memory modules
	LAN	<ul style="list-style-type: none"> ◆ Intel® I350 supports dual Gigabit ethernet LAN ports ◆ 1 x Management LAN port
	Expansion Slots	<ul style="list-style-type: none"> ◆ 1 x PCI Express x16 slot, running at x16 (Gen3/PCIe_1/Proprietary slot) ◆ 1 x PCI Express x8 slot, running at x8 (Gen3/PCIe_2/Proprietary slot)
	Onboard Graphics	<ul style="list-style-type: none"> ◆ ASPEED® AST2300 supports 16MB VRAM
	Storage Interface (SATA)	<ul style="list-style-type: none"> ◆ Intel® C602 controller ◆ 2 x SATA 6Gb/s connectors (SATA0/SATA1) ◆ 4 x SATA 3Gb/s connectors (SATA2/SATA3/SATA4/SATA5) ◆ Support for Intel RSTe SATA RAID 0, RAID 1
	USB	<ul style="list-style-type: none"> ◆ Up to 4 USB 2.0 ports (2 on the back panel, 2 additional ports via the USB brackets connected to the internal USB headers)
	Internal Connectors	<ul style="list-style-type: none"> ◆ 2x9 pin 12V power connector ◆ 2 x SATA 6Gb/s connectors ◆ 4 x SATA 3Gb/s connectors ◆ 1 x Front panel headers ◆ 1 x SATA SGPIO header ◆ 1 x Front panel VGA header ◆ 1 x Serial port header ◆ 1 x USB 2.0 header ◆ 1 x RAID KEY header ◆ 1 x IPMB connector

**Rear Panel I/O**

- ◆ 2 x USB 2.0 ports
- ◆ 2 x 100/1000 RJ-45 LAN ports
- ◆ 1 x 10/100 dedicated management LAN port
- ◆ 1 x Serial port
- ◆ 1 x VGA port
- ◆ 1 x Power switch button
- ◆ 1 x ID switch button
- ◆ 1 x Reset button
- ◆ 1 x BMC Reset button
- ◆ 1 x NMI button
- ◆ 1 x System status LED

**I/O Controller**

- ◆ ASPEED® AST2300 BMC chip

**Hardware Monitor**

- ◆ System voltage detection
- ◆ CPU/System temperature detection
- ◆ CPU/System fan speed detection
- ◆ CPU/System fan speed control
 - * Whether the CPU/system fan speed control function is supported will depend on the CPU/system cooler you install.

**BIOS**

- ◆ 1 x 64 Mbits flash
- ◆ AMI BIOS

**Form Factor**

- ◆ Propriety Form Factor; 6.5" inch x 19.2" inch, 12 layers PCB

* GIGABYTE reserves the right to make any changes to the product specifications and product-related information without prior notice.

1-3 Installing the CPU



Read the following guidelines before you begin to install the CPU:

- Make sure that the motherboard supports the CPU.
- Always turn off the computer and unplug the power cord from the power outlet before installing the CPU to prevent hardware damage.
- Locate the pin one of the CPU. The CPU cannot be inserted if oriented incorrectly. (Or you may locate the notches on both sides of the CPU and alignment keys on the CPU socket.)
- Apply an even and thin layer of thermal grease on the surface of the CPU.
- Do not turn on the computer if the CPU cooler is not installed, otherwise overheating and damage of the CPU may occur.
- Set the CPU host frequency in accordance with the CPU specifications. It is not recommended that the system bus frequency be set beyond hardware specifications since it does not meet the standard requirements for the peripherals. If you wish to set the frequency beyond the standard specifications, please do so according to your hardware specifications including the CPU, graphics card, memory, hard drive, etc.

1-3-1 Installing the CPU

A. Locate the alignment keys on the motherboard CPU socket and the notches on the CPU.

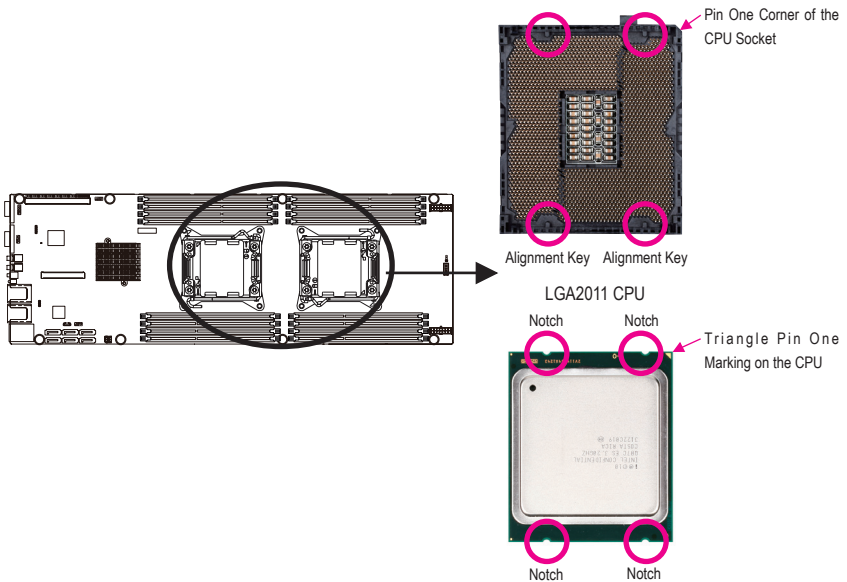

B. Follow the steps below to correctly install the CPU into the motherboard CPU socket.



- Before installing the CPU, make sure to turn off the computer and unplug the power cord from the power outlet to prevent damage to the CPU.
- To protect the socket contacts, do not remove the protective plastic cover unless the CPU is inserted into the CPU socket. Save the cover properly and replace it if the CPU is removed.

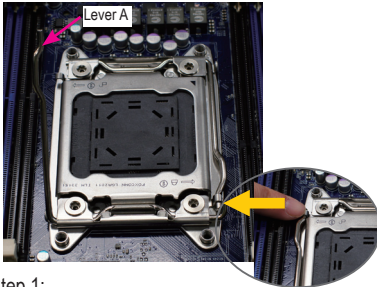

Step 1:

Push the lever closest to the "unlock" marking "☐" (below referred as lever A) down and away from the socket to release it.

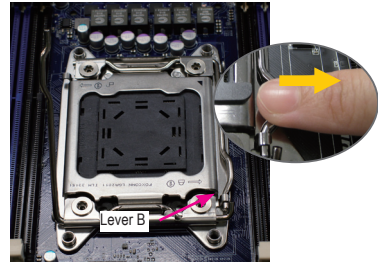

Step 2:

Push the lever closest to the "lock" marking "☒" (below referred as lever B) down and away from the socket. Then lift the lever.

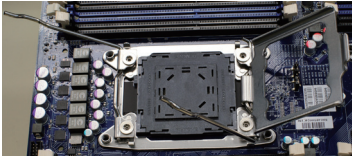

Step 3:

Gently press lever A to allow the load plate to rise. Open the load plate. (Note: DO NOT touch the socket contacts after the load plate is opened.)



Step 4:

Hold the CPU with your thumb and index fingers. Align the CPU pin one marking (triangle) with the pin one corner of the CPU socket (or align the CPU notches with the socket alignment keys) and carefully insert the CPU into the socket vertically.

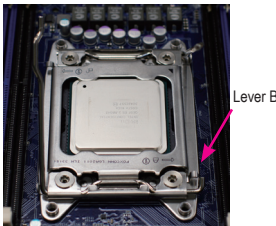

Step 5:

Once the CPU is properly inserted, carefully replace the load plate. Then secure lever B under its retention tab. The protective plastic cover may pop off from the load plate during the process of engaging the lever. Remove the cover. Save the cover properly and always replace it when the CPU is not installed.



Step 6:

Finally, secure lever A under its retention tab to complete the installation of the CPU.

1-4 Installing the Memory



Read the following guidelines before you begin to install the memory:

- Make sure that the motherboard supports the memory. It is recommended that memory of the same capacity, brand, speed, and chips be used.
(Go to GIGABYTE's website for the latest supported memory speeds and memory modules.)
- Always turn off the computer and unplug the power cord from the power outlet before installing the memory to prevent hardware damage.
- Memory modules have a foolproof design. A memory module can be installed in only one direction. If you are unable to insert the memory, switch the direction.

1-4-1 Four Channel Memory Configuration

This motherboard provides sixteen DDR3 memory sockets and supports Four Channel Technology. After the memory is installed, the BIOS will automatically detect the specifications and capacity of the memory. Enabling Four Channel memory mode will be four times of the original memory bandwidth.

The four DDR3 memory sockets are divided into four channels each channel has two memory sockets as following:

- Channel 1: DDR3_P0_A0/DDR3_P0_A1 (For primary CPU);
DDR3_P1_E0/DDR3_P1_E1 (For secondary CPU)
- Channel 2: DDR3_P0_B0/DDR3_P0_B1 (For primary CPU);
DDR3_P1_F0/DDR3_P1_F1 (For secondary CPU)
- Channel 3: DDR3_P0_C0/DDR3_P0_C1 (For primary CPU);
DDR3_P1_G0/DDR3_P1_G1 (For secondary CPU)
- Channel 4: DDR3_P0_D0/DDR3_P0_D1 (For primary CPU);
DDR3_P1_H0/DDR3_P1_H1 (For secondary CPU)

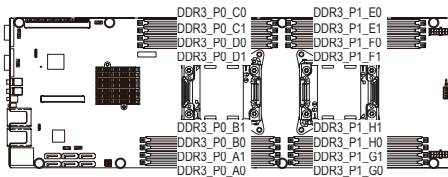

Due to CPU limitations, read the following guidelines before installing the memory in Four Channel mode.

1. Four Channel mode cannot be enabled if only one DDR3 memory module is installed.
2. When enabling Four Channel mode with two or four memory modules, it is recommended that memory of the same capacity, brand, speed, and chips be used for optimum performance.

1-4-2 Installing a Memory



Before installing a memory module, make sure to turn off the computer and unplug the power cord from the power outlet to prevent damage to the memory module.

Be sure to install DDR3 DIMMs on this motherboard.

Installation Step:

Step 1. Insert the DIMM memory module vertically into the DIMM slot, and push it down.

Step 2. Close the plastic clip at both edges of the DIMM slots to lock the DIMM module.

Note: For dual-channel operation, DIMMs must be installed in matched pairs.

Step 3. Reverse the installation steps when you wish to remove the DIMM module.

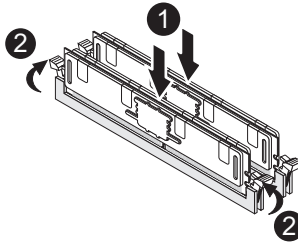

1-4-3 DIMM Population Table

	1N or 2N	DIMM1	DIMM0
R-DIMM	1N	Empty	Single-Rank
	1N	Empty	Dual-Rank
	1N	Empty	Quad-Rank
	2N	Single-Rank	Single-Rank
	2N	Dual-Rank	Dual-Rank
	2N	Quad-Rank	Quad-Rank

	1N or 2N	DIMM1	DIMM0
U-DIMM	1N	Empty	Single-Rank
	1N	Empty	Dual-Rank
	2N	Single-Rank	Single-Rank
	2N	Dual-Rank	Dual-Rank
	2N	Dual-Rank	Dual-Rank

1-5 Back Panel Connectors

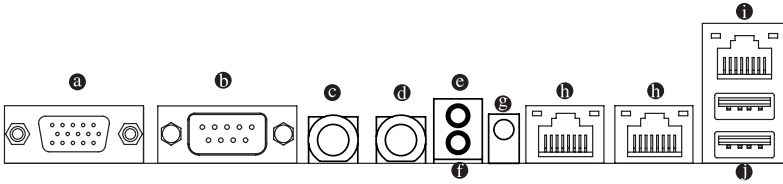

a Video Port

The video in port allows connect to video in, which can also apply to video loop thru function.

b Serial Port

Connects to serial-based mouse or data processing devices.

c Power Switch Button

Press the button to power on/off the system.

d ID Switch Button

This button provide the selected unit idfication function.

e BMC Reset Button

Press the button to reset the BMC.

f NMI Button

The Non-Maskable Interrupt (NMI) button allows server generates a NMI to the processor if the multiple-bit ECC errors occur, which effectively halt the server.

g Status LED

The Status LED indicates the system health status. When the LED is solid on, check the following:

- Power module failure
- System fan failure
- Power supply voltage issue
- System temperature/voltage issue

h RJ-45 LAN Port

The Gigabit Ethernet LAN port provides Internet connection at up to 1 Gbps data rate. The following describes the states of the LAN port LEDs.

i KVM Server Management 10/100 LAN Port

The LAN port provides Internet connection with data transfer speeds of 10/100Mbps.

j USB 2.0Port

The USB port supports the USB 2.0 specification. Use this port for USB devices such as a USB keyboard/mouse, USB printer, USB flash drive and etc.

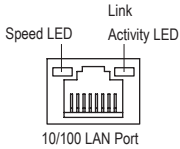

10/100 (MLAN) Speed LED:

State	Description
Green On	100 Mbps data rate
Green Blink	10 Mbps or 100 Mbps data rate
Off	10 Mbps data rate

Link/Activity LED:

State	Description
On	Link between system and network or no access
Blinking	Data transmission or receiving is occurring
Off	No data transmission or receiving is occurring

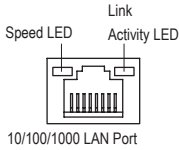

10/100/1000 (GbE) Speed LED:

State	Description
Yellow On	1 Gbps data rate
Yellow Blink	Identify 1 Gbps data rate
Green On	100 Mbps data rate
Green Blink	Identify 100 Mbps data rate
Off	10 Mbps data rate

Link/Activity LED:

State	Description
On	Link between system and network or no access
Blinking	Data transmission or receiving is occurring
Off	No data transmission or receiving is occurring



- When removing the cable connected to a back panel connector, first remove the cable from your device and then remove it from the motherboard.
- When removing the cable, pull it straight out from the connector. Do not rock it side to side to prevent an electrical short inside the cable connector.

1-6 Internal Connectors

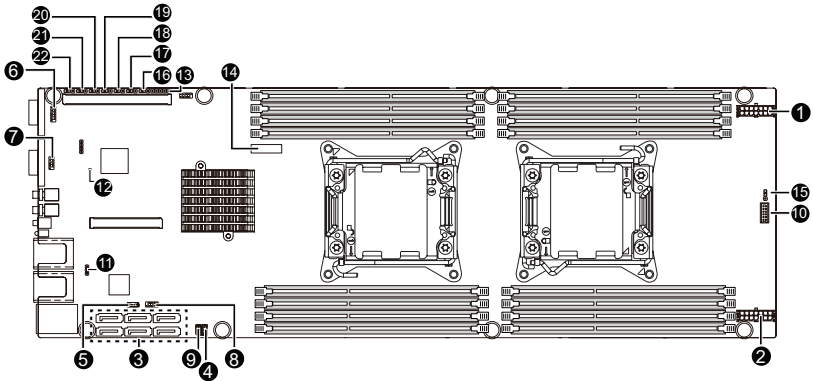

1)	SSI_2X9P1	12)	BMC_LED1
2)	SSI_2X9P2	13)	PWR_DET
3)	SATA0/1/2/3/4/5	14)	BAT1
4)	RAID_KEY1	15)	ACK_SEL
5)	SATA_SGPIO	16)	BIOS_RVCR1
6)	FP_VGA1	17)	SSB_ME1
7)	COM2	18)	PASSWORD1
8)	USB1	19)	CLR_CMOS1
9)	IPMB1	20)	BIOS_WP1
10)	F_PANEL	21)	FLASH_DP1
11)	LAN_LED	22)	BMC_FRB



Read the following guidelines before connecting external devices:

- First make sure your devices are compliant with the connectors you wish to connect.
- Before installing the devices, be sure to turn off the devices and your computer. Unplug the power cord from the power outlet to prevent damage to the devices.
- After installing the device and before turning on the computer, make sure the device cable has been securely attached to the connector on the motherboard.

1/2) SSI_2X9P1/SSI_2X9P2 (2x9 12V Power Connectors)

With the use of the power connector, the power supply can supply enough stable power to all the components on the motherboard. Before connecting the power connector, first make sure the power supply is turned off and all devices are properly installed. The power connector possesses a foolproof design. Connect the power supply cable to the power connector in the correct orientation. The 12V power connector mainly supplies power to the CPU. If the 12V power connector is not connected, the computer will not start.



- To meet expansion requirements, it is recommended that a power supply that can with stand high power consumption be used (1000W / 12V standby 2A or greater). If a power supply is used that does not provide the required power, the result can lead to an unstable or unbootable system.

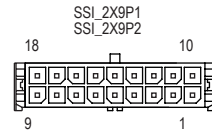
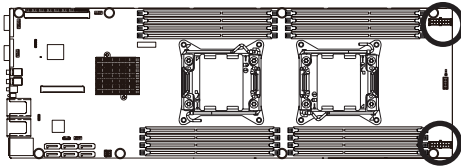

Pin No.	Definition	Pin No.	Definition
1	GND	10	12VSB
2	GND	11	12V
3	GND	12	12V
4	GND	13	12V
5	GND	14	12V
6	GND	15	12V
7	GND	16	12V
8	GND	17	12V
9	GND	18	12V

3) SATA0/SATA1 (SATA 6Gb/s Connectors)

SATA2/SATA3/SATA4/SATA5 (SATA 3Gb/s Connectors)

The SATA connectors conform to SATA 6Gb/s standard and are compatible with SATA 3Gb/s and 1.5Gb/s standard. Each SATA connector supports a single SATA device.

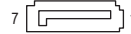
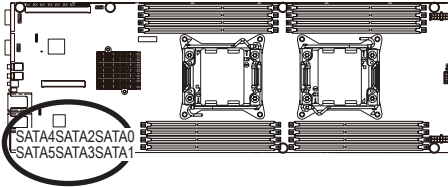

Pin No.	Definition
1	GND
2	TXP
3	TXN
4	GND
5	RXN
6	RXP
7	GND



- A RAID 0 or RAID 1 configuration requires at least two hard drives. If more than two hard drives are configured, the total number of hard drives must be an even number.
- A RAID 10 configuration requires four hard drives.

(Note) When a RAID configuration is built across the SATA 6Gb/s channels, the system performance of the RAID configuration may vary depends on the devices are connected.

4) RAID_KEY1 (RAID Selection Connector/Optional)

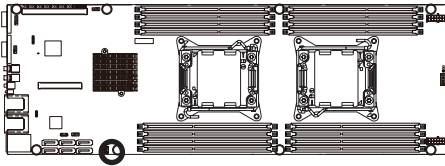

Pin No.	Definition
1	GND
2	SSB_SAS/SATA_RAID_KEY
3	GND

5) SATA_SGPIO (SATA SGPIO Header)

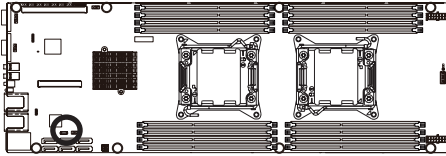

Pin No.	Definition
1	SDIN
2	GND
3	SDOUT
4	SLOAD
5	SCLK

6) FP_VGA1 (Front VGA Header)

The Front VGA header provides switch function between front VGA and rear VGA. When the front VGA is enabled, the rear VGA function will be disabled.

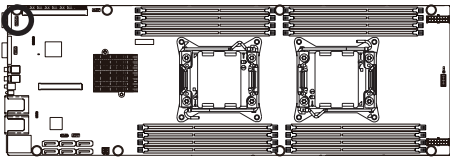

Pin No.	Definition
1	VGA_FP_VS
2	VGA_FP_HS
3	VGA_FP_PWR
4	VGA_FP_DDC_CLK
5	FP_N
6	VGA_FP_DDC_DAT
7	VGA_FP_G
8	GND
9	VGA_FP_B
10	GND
11	VGA_FP_R
12	No Pin

	Active Status	Display
FP_N	H	Rear VGA
	L	Front VGA

7) COM2 (Serial Port Header)

The COM header can provide one serial port via an optional COM port cable. For purchasing the optional COM port cable, please contact the local dealer.

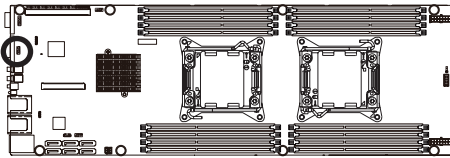

Pin No.	Definition
1	NDCDB_N
2	NSINB
3	NSOUTB
4	NDTRB_N
5	GND
6	NDSRB_N
7	NRTSB_N
8	NCTSB_N
9	NRIB_N
10	No Pin

8) USB1 (Front USB Header)

The headers conform to USB 2.0/1.1 specification. Each USB header can provide two USB ports via an optional USB bracket. For purchasing the optional USB bracket, please contact the local dealer.

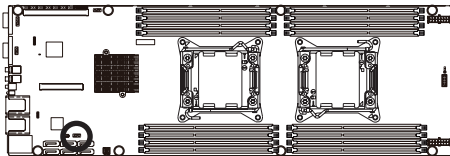

Pin No.	Definition
1	Power (5V)
2	Power (5V)
3	USB DX-
4	USB DY-
5	USB DX+
6	USB DY+
7	GND
8	GND
9	No Pin
10	NC

10) F_PANEL (Front Panel Header)

Connect the power switch, reset switch, speaker, chassis intrusion switch/sensor and system status indicator on the chassis to this header according to the pin assignments below. Note the positive and negative pins before connecting the cables.

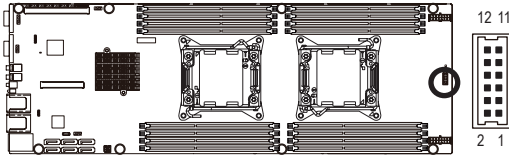

Pin No.	Definition
1	CTNR_PS_ON_N
2	I2C_FCB_SCL
3	PSU_PGD_PS
4	I2C_FCB_SDA
5	FCB_REQ_N
6	BMC_LED_PWR_GRN_R_N
7	BTN_FP_PER_N
8	BMC_SYS_HLTH_LED_R_N
9	ACK_N
10	BMC_UID_LED_N
11	GND
12	BMC_UID_BUTTON_TTL_N



The front panel design may differ by chassis. A front panel module mainly consists of power switch, power LED, and etc. When connecting your chassis front panel module to this header, make sure the wire assignments and the pin assignments are matched correctly.

11) LAN_LED (LAN1 port and LAN2 port active LED Header)

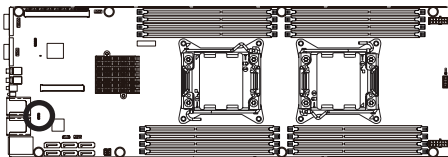

Pin No.	Definition
1	LED_NIC_LINK0_ACT_N
2	P3V3_AUX
3	LED_NIC_LINK1_ACT_N

12) BMC_LED1 (BMC Firmware Readiness LED)

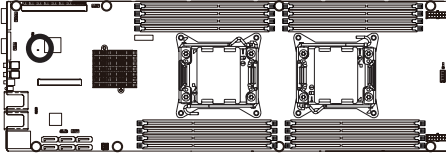

State	Description
On	BMC firmware is initial
Blinking	BMC firmware is ready
Off	System is powered off

13) PWR_DET (PMBus header)

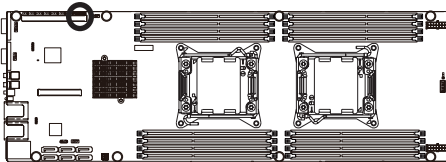

Pin No.	Definition
1	SMB CLK
2	SMB DATA
3	SMB Alert
4	GND
5	3.3V Sense

14) BAT1 (Battery)

The battery provides power to keep the values (such as BIOS configurations, date, and time information) in the CMOS when the computer is turned off. Replace the battery when the battery voltage drops to a low level, or the CMOS values may not be accurate or may be lost.

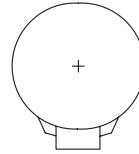
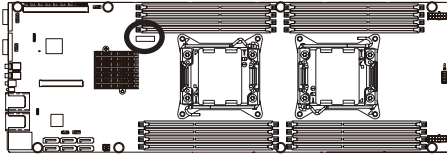

- Always turn off your computer and unplug the power cord before replacing the battery.
- Replace the battery with an equivalent one. Danger of explosion if the battery is replaced with an incorrect model.
- Contact the place of purchase or local dealer if you are not able to replace the battery by yourself or uncertain about the battery model.
- When installing the battery, note the orientation of the positive side (+) and the negative side (-) of the battery (the positive side should face up).
- Used batteries must be handled in accordance with local environmental regulations.

15) ACK_SEL (4 Nodes System and Rack System switch Jumper)

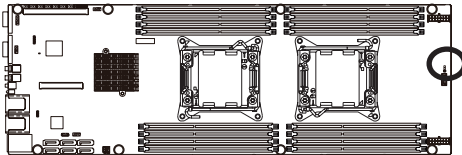

1  1-2 Close: 4 Node System.

1  2-3 Close: Rack System.

16) BIOS_RVCR1 (BIOS Recovery Jumper)

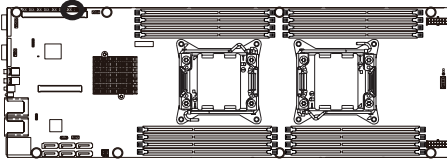

1  1-2 Close: Normal operation. (Default setting)

1  2-3 Close: BIOS recovery mode.

17) SSB_ME1 (ME enable/disable Jumper)

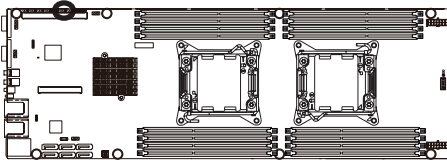

1  1-2 Close: Normal operation. (Default setting)

1  2-3 Close: Disable ME function.

18) PASSWORD1 (Clearing Supervisor Password Jumper)

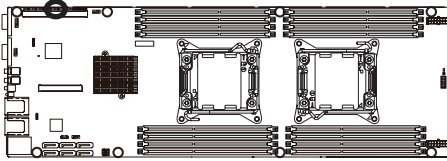

1  1-2 Close: Normal operation. (Default setting)

1  2-3 Close: Clear supervisor password.

19) CLR_CMOS (Clearing CMOS Jumper)

Use this jumper to clear the CMOS values (e.g. date information and BIOS configurations) and reset the CMOS values to factory defaults. To clear the CMOS values, place a jumper cap on the two pins to temporarily short the two pins or use a metal object like a screwdriver to touch the two pins for a few seconds.

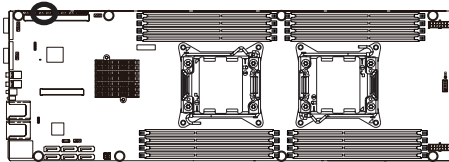

1  1-2 Close: Normal operation (Default setting)

1  2-3 Close: Clear CMOS data.



- Always turn off your computer and unplug the power cord from the power outlet before clearing the CMOS values.
- After clearing the CMOS values and before turning on your computer, be sure to remove the jumper cap from the jumper. Failure to do so may cause damage to the motherboard.
- After system restart, go to BIOS Setup Exit menu and load factory defaults (select **Restore Defaults**) or manually configure the BIOS settings (refer to Chapter 2, "BIOS Setup," for BIOS configurations).

20) BIOS_WP1 (BIOS Write Protect Jumper)

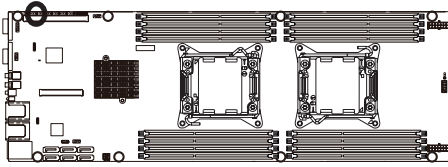

1  1-2 Close: Normal operation. (Default setting)

1  2-3 Close: Enable BIOS write protect function.

21) FLASH_DP1 (Flash Descriptor Security Jumper)

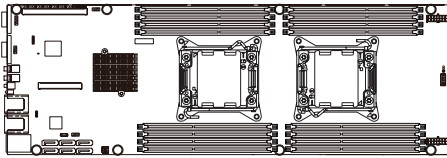

1  1-2 Close: Flash Descriptor Security Overridden.

1  2-3 Close: Flash Descriptor Security in effect. (Default setting)

22) BMC_FRB1 (Force to Stop FRB Timer Jumper)

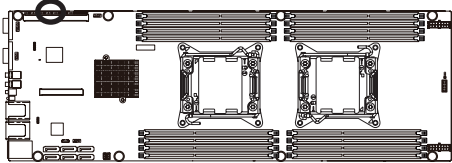

1  1-2 Close: Normal operation. (Default setting)

1  2-3 Close: Force to Stop FRB Timer.

Chapter 2 BIOS Setup

BIOS (Basic Input and Output System) records hardware parameters of the system in the EFI on the motherboard. Its major functions include conducting the Power-On Self-Test (POST) during system startup, saving system parameters and loading operating system, etc. BIOS includes a BIOS Setup program that allows the user to modify basic system configuration settings or to activate certain system features. When the power is turned off, the battery on the motherboard supplies the necessary power to the CMOS to keep the configuration values in the CMOS.

To access the BIOS Setup program, press the <F2> key during the POST when the power is turned on.



- BIOS flashing is potentially risky, if you do not encounter problems of using the current BIOS version, it is recommended that you don't flash the BIOS. To flash the BIOS, do it with caution. Inadequate BIOS flashing may result in system malfunction.
- It is recommended that you not alter the default settings (unless you need to) to prevent system instability or other unexpected results. Inadequately altering the settings may result in system's failure to boot. If this occurs, try to clear the CMOS values and reset the board to default values. (Refer to the "Restore Defaults" section in this chapter or introductions of the battery/clearing CMOS jumper in Chapter 1 for how to clear the CMOS values.)

BIOS Setup Program Function Keys

<<-><->>	Move the selection bar to select the screen
<↑><↓>	Move the selection bar to select an item
<Enter>	Execute command or enter the submenu
<+>	Increase the numeric value or make changes
<->	Decrease the numeric value or make changes
<Esc>	Main Menu: Exit the BIOS Setup program Submenus: Exit current submenu
<F1>	Show descriptions of general help
<F3>	Restore the previous BIOS settings for the current submenus
<F9>	Load the Optimized BIOS default settings for the current submenus
<F10>	Save all the changes and exit the BIOS Setup program

- **Main**

This setup page includes all the items in standard compatible BIOS.

- **Advanced**

This setup page includes all the items of AMI BIOS special enhanced features.

(ex: Auto detect fan and temperature status, automatically configure hard disk parameters.)

- **Chipset**

This setup page includes all the submenu options for configuring the function of North Bridge and South Bridge.

(ex: Auto detect fan and temperature status, automatically configure hard disk parameters.)

- **Security**

Change, set, or disable supervisor and user password. Configuration supervisor password allows you to restrict access to the system and BIOS Setup.

A supervisor password allows you to make changes in BIOS Setup.

A user password only allows you to view the BIOS settings but not to make changes.

- **Server Management**

Server additional features enabled/disabled setup menus.

- **Boot**

This setup page provides items for configuration of boot sequence.

- **Exit**

Save all the changes made in the BIOS Setup program to the CMOS and exit BIOS Setup. (Pressing <F10> can also carry out this task.)

Abandon all changes and the previous settings remain in effect. Pressing <Y> to the confirmation message will exit BIOS Setup. (Pressing <Esc> can also carry out this task.)

2-1 The Main Menu

Once you enter the BIOS Setup program, the Main Menu (as shown below) appears on the screen. Use arrow keys to move among the items and press <Enter> to accept or enter other sub-menu.

Main Menu Help

The on-screen description of a highlighted setup option is displayed on the bottom line of the Main Menu.

Submenu Help

While in a submenu, press <F1> to display a help screen (General Help) of function keys available for the menu. Press <Esc> to exit the help screen. Help for each item is in the Item Help block on the right side of the submenu.



- When the system is not stable as usual, select the **Restore Defaults** item to set your system to its defaults.
- The BIOS Setup menus described in this chapter are for reference only and may differ by BIOS version.

Bios Setup Utility	
Main Advanced Chipset Security Server Mgmt Boot Save & Exit	
BIOS Information	
Project Version	R07
Build Date and Time	12/26/2013 11:19:03
Fan Speed Control Board	
Firmware Version	01.09
BMC Information	
BMC Firmware Version	00.02
SDR Revision	00.01
FRU Version	00.01
LAN MAC Information	
LAN1 MAC Address	94-DE-80-17-B7-A2
LAN2 MAC Address	94-DE-80-17-B7-A3
Processor Information	
CPU 0	Intel(R) Xeon(R) CPU E5-2637
CPU 1	Intel(R) Xeon(R) CPU E5-2637
Max CPU Speed	3500 MHz
CPU Signature	306e4
Processor Cores	4 x 2
Microcode Patch	416
Memory Information	

▲ Set the Date. Use Tab to switch between Date elements.

++: Select Screen
F1: Select Item
Enter: Select
+/-: Change Opt.
F1: General Help
F3: Previous Values
F9: Optimized Defaults
F10: Save & Exit
ESC: Exit

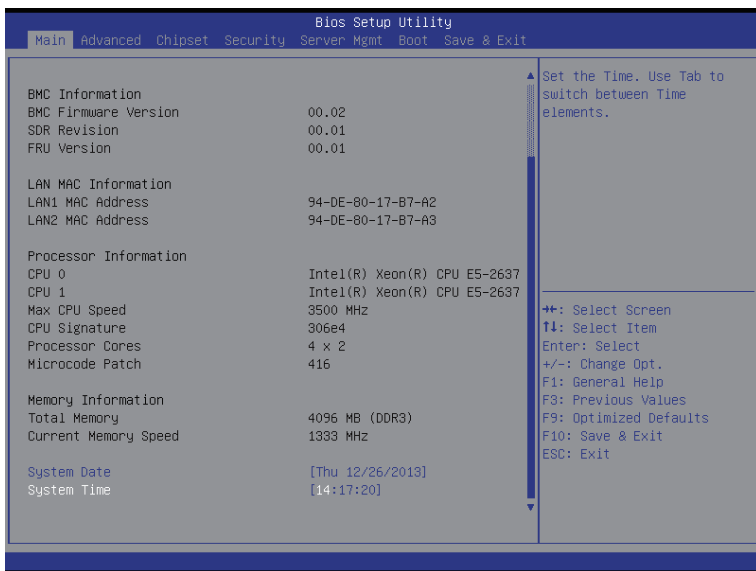

☞ **BIOS Information**

☞ **Project Version**

Display version number of the project.

☞ **BIOS Build Date and Time**

Displays the date and time when the BIOS setup utility was created.

☞ **BMC Information**

☞ **BMC Firmware Version**

Display version number of the Firmware setup utility.

☞ **SDR Reversion**

Display the SDR reversion information.

☞ **FRU Version**

Display the FRU reversion information.

☞ **LAN MAC Information**

☞ **LAN1 MAC Address**

Display LAN1 MAC address information.

☞ **LAN2 MAC Address**

Display LAN2 MAC address information.

☞ **Processor Information**

☞ **CPU Type/ Max CPU Speed/ CPU Signature / Processor Cores / Microcode Patch**

Displays the technical specifications for the installed processor.

☞ **Memory Information**

☞ **Total Memory / Current Memory Speed**

Displays the technical specifications for the installed memory.

☞ **System Date**

Set the date following the weekday-month-day- year format.

☞ **System Time**

Set the system time following the hour-minute- second format.

2-2 Advanced Menu

The Advanced menu display submenu options for configuring the function of various hardware components. Select a submenu item, then press Enter to access the related submenu screen.

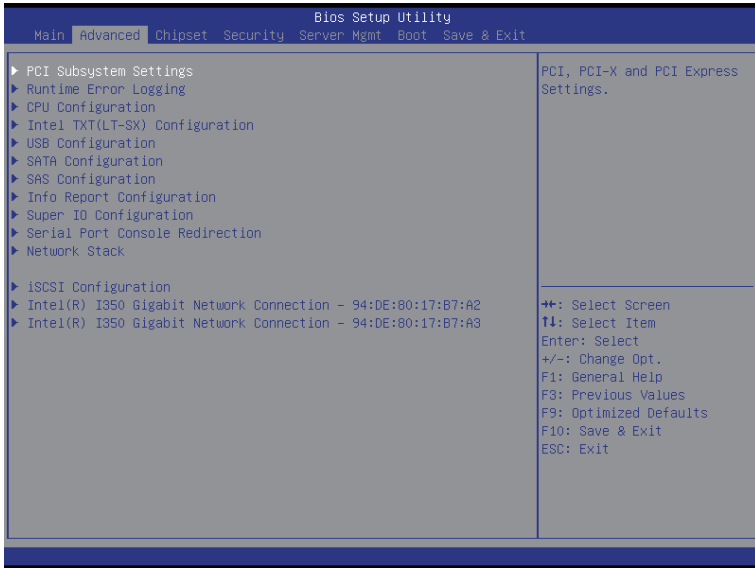

2-2-1 PCI Subsystem Settings



☞ PCI Express Slot 1/2 I/O ROM

When enabled, This setting will initialize the device expansion ROM for the related PCI-E slot.
Options available: Enabled/Disabled. Default setting is **Enabled**.

☞ Onboard LAN1/2 Controller

Enable/Disable Onboard LAN controllers.
Options available: Enabled/Disabled. Default setting is **Enabled**.

☞ LAN OPROM Shadow Option

Configure onboard LAN devices and initialize device expansion ROM.
Options available: PXE/SCSI. Default setting is **PXE**.

☞ Onboard LAN1/2 I/O ROM

Enable/Disable onboard LAN devices and initialize device expansion ROM.
Options available: Enabled/Disabled. Default setting is **Disabled**.

☞ PCI 64bit Resources Handling

☞ Above 4G Decoding

Enable/Disable Above 4G Decoding.
Options available: Enabled/Disabled. Default setting is **Disabled**.

☞ PCI Common Settings

☞ PCI Latency Timer

Configure PCI Latency Timer.
Options available: 32 PCI Bus Clocks/64 PCI Bus Clocks/96 PCI Bus Clocks/128 PCI Bus Clocks/160 PCI Bus Clocks/192 PCI Bus Clocks/224 PCI Bus Clocks/248 PCI Bus Clocks.
Default setting is **32 PCI Bus Clocks**.

☞ **VGA Platte Snoop**

Enable/Disable VGA Palette Registers Snooping.

Options available: Enabled/Disabled. Default setting is **Disabled**.

☞ **PERR Generation**

When this item is set to enabled, PCI bus parity error (PERR) is generated and is routed to NMI.

Options available: Enabled/Disabled. Default setting is **Disabled**.

☞ **SERR Generation**

When this item is set to enabled, PCI bus system error (SERR) is generated and is routed to NMI.

Options available: Enabled/Disabled. Default setting is **Disabled**.

☞ **PCI Express Settings**

Press [Enter] for configuration of advanced items.

2-2-1-1 PCI Express Settings

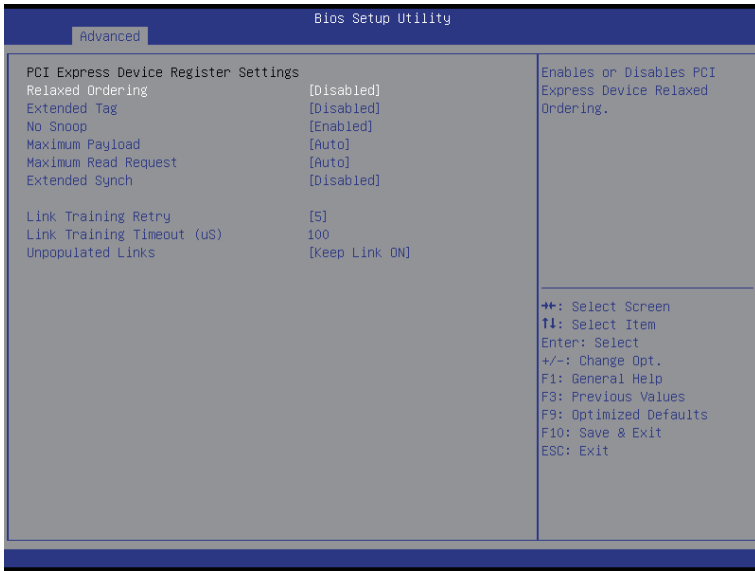

☞ PCI Express Device Register Settings

☞ Relaxed Ordering

Enable/Disable PCI Express Device Relaxed Ordering feature.
Options available: Enabled/Disabled. Default setting is **Disabled**.

☞ Extended Tag

When this feature is enabled, the system will allow device to use 8-bit Tag field as a requester.
Options available: Enabled/Disabled. Default setting is **Disabled**.

☞ No Snoop

Enable/Disable PCI Express Device No Snoop option.
Options available: Enabled/Disabled. Default setting is **Enabled**.

☞ Maximum Payload

Set maximum payload for PCI Express Device or allow system BIOS to select the value.
Options available: Auto/128 Bytes/256 Bytes/512 Bytes/1024 Bytes/2048 Bytes/4096 Bytes.
Default setting is **Auto**.

☞ Maximum Read Request

Set maximum Read Request size for PCI Express Device or allow system BIOS to select the value.
Options available: Auto/128 Bytes/256 Bytes/512 Bytes/1024 Bytes/2048 Bytes/4096 Bytes.
Default setting is **Auto**.

☞ Extended Synch

When this feature is enabled, the system will allow generation of Extended Synchronization patterns.
Options available: Enabled/Disabled. Default setting is **Enabled**.

☞ **Link Training Retry**

Define the number of Retry Attempts software will take to retrain the link if previous training attempt was unsuccessful. Press <+> / <-> keys to increase or decrease the desired values.

☞ **Link Training Timeout (us)**

Define the number of Microseconds software will wait before polling 'Link Training' bit in Link Status register. Press <+> / <-> keys to increase or decrease the desired values. Value rang is from 10 to 10000 us.

☞ **Unpopulated Links**

When this item is set to 'Disable Link', the system will operate power save feature for those unpopulated PCI Express links.

Options available: Keep Link ON/ Disable. Default setting is **Keep Link ON**.

2-2-2 Runtime Error Logging

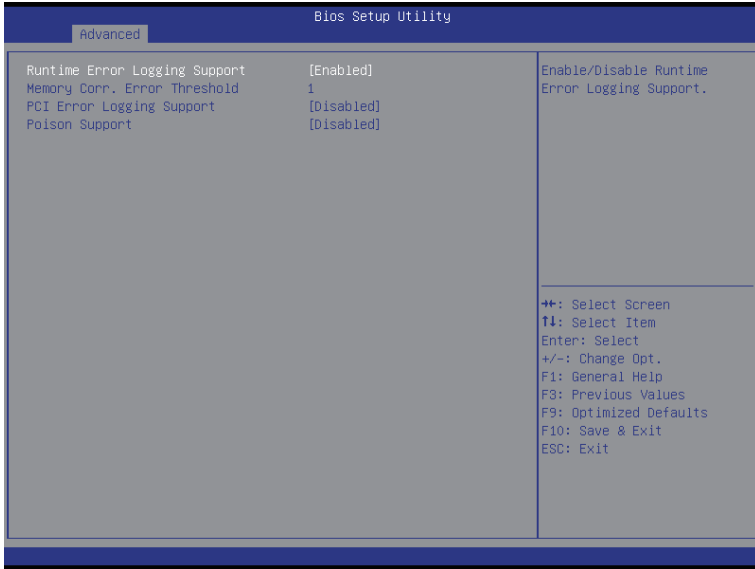

☞ Runtime Error Logging

Enable/Disable Runtime error logging support.

Options available: Enabled/Disabled. Default setting is **Disabled**.

☞ Memory Corr. Error Threshold^(Note)

Press <+> / <-> keys to increase or decrease the desired values.

☞ PCI Error Logging Support^(Note)

Enable/Disable PCI Error Logging Support.

Options available: Enabled/Disabled. Default setting is **Disabled**.

☞ Poison Support^(Note)

Enable/Disable Poison Support.

Options available: Enabled/Disabled. Default setting is **Disabled**.

(Note) This item appears when **Runtime Error Logging** is set to **Enabled**.

2-2-3 CPU Configuration

Bios Setup Utility

Advanced

<p>CPU Configuration</p> <ul style="list-style-type: none"> ▶ Socket 0 CPU Information ▶ Socket 1 CPU Information <p>CPU Speed 3500 MHz 64-bit Supported</p> <p>Hyper-threading [Enabled] Active Processor Cores [All] Limit CPUID Maximum [Disabled] Execute Disable Bit [Enabled] Hardware Prefetcher [Enabled] Adjacent Cache Line Prefetch [Enabled] DCU Streamer Prefetcher [Enabled] DCU IP Prefetcher [Enabled] Intel Virtualization Technology [Enabled] PPIN Support [Disabled]</p> <ul style="list-style-type: none"> ▶ CPU Power Management Configuration 		<p>Socket specific CPU Information</p> <hr/> <p>++: Select Screen ↑↓: Select Item Enter: Select +/-: Change Opt. F1: General Help F8: Previous Values F9: Optimized Defaults F10: Save & Exit ESC: Exit</p>
---	--	---

Bios Setup Utility

Advanced

<p>Socket 0 CPU Information</p> <p>Intel(R) Xeon(R) CPU E5-2637 v2 @ 3.50GHz CPU Signature 306e4 Microcode Patch 416 Max CPU Speed 3500 MHz Min CPU Speed 1200 MHz Processor Cores 4 Intel HT Technology Supported Intel VT-x Technology Supported Intel SMX Technology Supported</p> <p>L1 Data Cache 32 kB x 4 L1 Code Cache 32 kB x 4 L2 Cache 256 kB x 4 L3 Cache 15360 kB</p>		<p>++: Select Screen ↑↓: Select Item Enter: Select +/-: Change Opt. F1: General Help F8: Previous Values F9: Optimized Defaults F10: Save & Exit ESC: Exit</p>
--	--	--

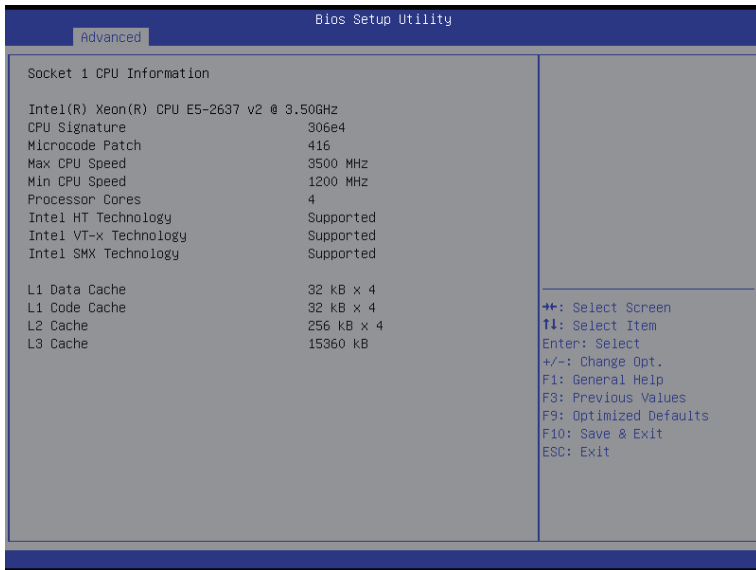

☞ **CPU Information**

☞ **Socket 0/1 CPU Information**

☞ **CPU Type/ Signature / Microcode Patch / Max CPU Speed / Min CPU Speed / Processor Cores**

Displays the technical specifications for the installed processor.

☞ **Intel HT Technology / Intel VT-x Technology / Intel SMX Technology**

Displays the support information for the installed processor.

☞ **Cache Information**

☞ **L1 Data Cache / L1 Code Cache / L2 Cache / L3 Cache**

Displays the technical specifications for the installed processor.

☞ **CPU Speed / 64-bit**

Displays the technical specifications for the installed processor.

☞ **Hyper-threading ^(Note)**

The Intel Hyper Threading Technology allows a single processor to execute two or more separate threads concurrently. When hyper-threading is enabled, multi-threaded software applications can execute their threads, thereby improving performance.

Options available: Enabled/Disabled. Default setting is **Enabled**.

☞ **Active Processor Cores ^(Note)**

Allows you to determine whether to enable all CPU cores.

Options available: All/1/2/3. Default setting is **All**.

(Note) This item is present only if you install a CPU that supports this feature. For more information about Intel CPUs' unique features, please visit Intel's website.

☞ **Limit CPUID Maximum**

When enabled, the processor will limit the maximum CPUID input values to 03h when queried, even if the processor supports a higher CPUID input value.

When disabled, the processor will return the actual maximum CPUID input value of the processor when queried.

Options available: Enabled/Disabled. Default setting is **Disabled**.

☞ **Execute Disable Bit**

When enabled, the processor prevents the execution of code in data-only memory pages. This provides some protection against buffer overflow attacks.

When disabled, the processor will not restrict code execution in any memory area. This makes the processor more vulnerable to buffer overflow attacks.

Options available: Enabled/Disabled. Default setting is **Enabled**.

☞ **Hardware Prefetcher**

Select whether to enable the speculative prefetch unit of the processor.

Options available: Enabled/Disabled. Default setting is **Enabled**.

☞ **Adjacent Cache Line Prefetch**

When enabled, cache lines are fetched in pairs. When disabled, only the required cache line is fetched.

Options available: Enabled/Disabled. Default setting is **Enabled**.

☞ **DCU Streamer Prefetch**

Enable prefetch of next L1 Data line based upon multiple loads in same cache line.

Options available: Enabled/Disabled. Default setting is **Enabled**.

☞ **DCU IP Prefetch**

Enable prefetch of next L1 Data line based upon sequential load history.

Options available: Enabled/Disabled. Default setting is **Enabled**.

☞ **Intel Virtualization Technology**

Select whether to enable the Intel Virtualization Technology function. VT allows a single platform to run multiple operating systems in independent partitions.

Options available: Enabled/Disabled. Default setting is **Enabled**.

☞ **PPIN Support**

Enable/Disable PPIN Support function.

Options available: Enabled/Disabled. Default setting is **Disabled**.

☞ **CPU Power Management Configuration**

Press [Enter] for configuration of advanced items.

2-2-3-1 CPU Power Management Configuration

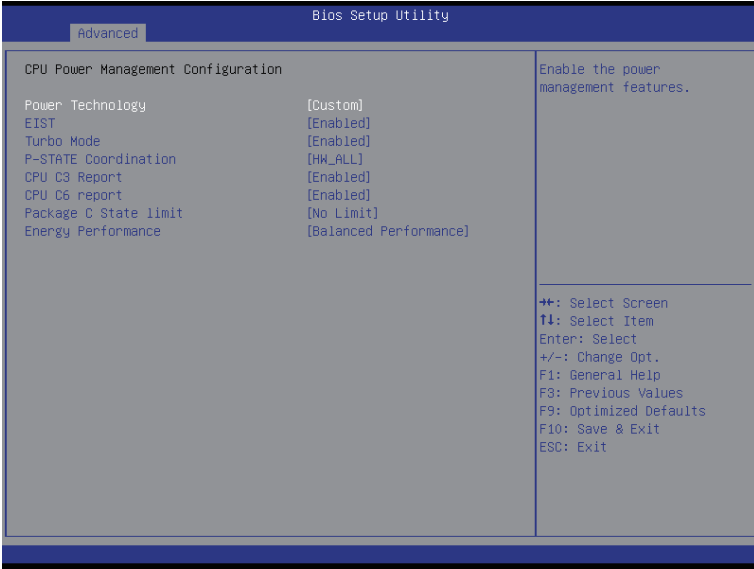

☞ CPU Power Management Configuration

☞ Power Technology

Configure the power management features.

Options available: Disable/Energy Efficient/Custom. Default setting is **Custom**.

☞ EIST (Enhanced Intel SpeedStep Technology)

Conventional Intel SpeedStep Technology switches both voltage and frequency in tandem between high and low levels in response to processor load.

Options available: Enabled/Disabled. Default setting is **Enabled**.

☞ Turbo Mode

When this item is enabled, the processor will automatically ramp up the clock speed of 1-2 of its processing cores to improve its performance.

When this item is disabled, the processor will not overclock any of its core.

Options available: Enabled/Disabled. Default setting is **Enabled**.

☞ P-STATE Coordination

In HW_ALL mode, the processor hardware is responsible for coordinating the P-state among logical processors dependencies. The OS is responsible for keeping the P-state request up to date on all logical processors.

In SW_ALL mode, the OS Power Manager is responsible for coordinating the P-state among logical processors with dependencies and must initiate the transition on all of those Logical Processors.

In SW_ANY mode, the OS Power Manager is responsible for coordinating the P-state among logical processors with dependencies and may initiate the transition on any of those Logical Processors.

Options available: HW_ALL/SW_ALL/SW_ANY. Default setting is **HW_ALL**.

☞ CPU C3/C6 Report ^(Note)

Allows you to determine whether to let the CPU enter C3/C6 mode in system halt state. When enabled, the CPU core frequency and voltage will be reduced during system halt state to decrease power consumption. The C3/C6 state is a more enhanced power-saving state than C1.

Options available: Enabled/Disabled. Default setting is **Enabled**.

☞ Package C State Limit

Configure state for the C-State package limit.

Options available: C0/C1/C6/C7/No Limit. Default setting is **No Limit**.

☞ Energy Performance

Energy Performance Bias is Intel CPU function.

The larger value in MSR_ENERGY_PERFORMANCE_BIAS register, CPU will save more power but lose more performance.

Note: This register will be changed by OS too if OS support it like Windows 2008 or newer Linux.

Options available:

Performance : Write value 0 into MSR_ENERGY_PERFORMANCE_BIAS

Balanced Performance: Write value 7 into MSR_ENERGY_PERFORMANCE_BIAS

Balanced Energy: Write value 11 into MSR_ENERGY_PERFORMANCE_BIAS

Energy Efficient: Write value 15 into MSR_ENERGY_PERFORMANCE_BIAS

Default setting is **Performance**.

(Note) This item is present only if you install a CPU that supports this feature. For more information about Intel CPUs' unique features, please visit Intel's website.

2-2-4 Intel TXT (LT-SX) Configuration

Press Enter to view the Intel TXT (LT-SX) Configuration screen which displays Intel TXT Configuration support information, Items on this window are non-configurable.

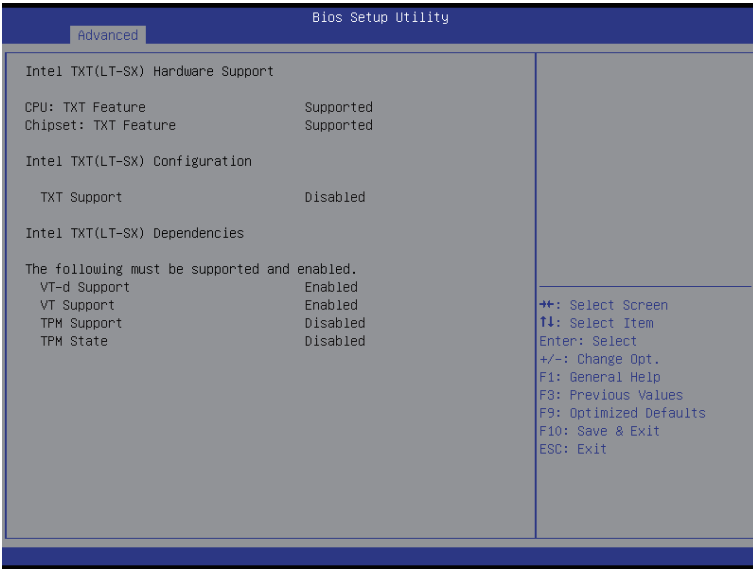

2-2-5 USB Configuration

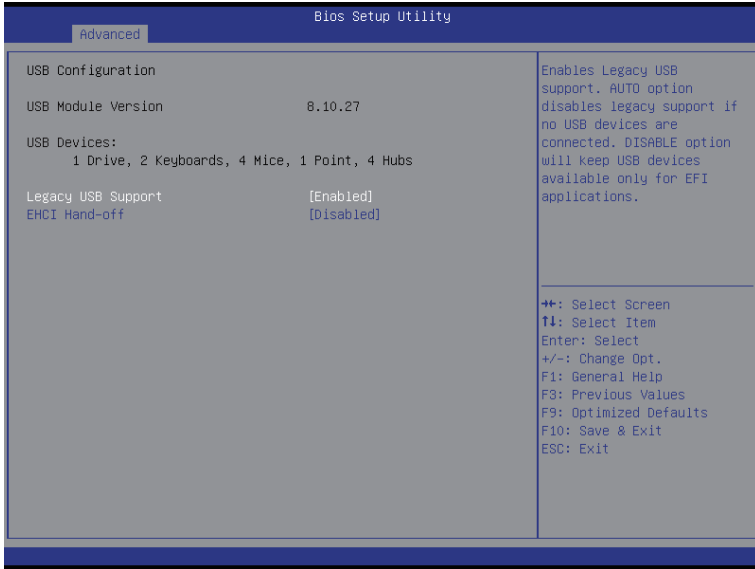

☞ USB Configuration

☞ Legacy USB Support

Enables or disables support for legacy USB devices.

Options available: Auto/Enabled/Disabled. Default setting is **Enabled**.

☞ EHCI Hand-off

Enable/Disable EHCI (USB 2.0) Hand-off function.

Options available: Enabled/Disabled. Default setting is **Disabled**.

2-2-6 SATA Configuration

Bios Setup Utility

Advanced

SATA Configuration

SATA Port0	Not Present	
SATA Port1	Not Present	
SATA Port2	Not Present	
SATA Port3	Not Present	
SATA Port4	Not Present	
SATA Port5	Not Present	
SATA Mode		[AHCI Mode]
Aggressive Link Power Management		[Enabled]
Port 0 Hot Plug		[Disabled]
Port 1 Hot Plug		[Disabled]
Port 2 Hot Plug		[Disabled]
Port 3 Hot Plug		[Disabled]
Port 4 Hot Plug		[Disabled]
Port 5 Hot Plug		[Disabled]
External SATA Port 0		[Disabled]
External SATA Port 1		[Disabled]
External SATA Port 2		[Disabled]
External SATA Port 3		[Disabled]
External SATA Port 4		[Disabled]
External SATA Port 5		[Disabled]

(1) IDE Mode. (2) AHCI Mode. (3) RAID Mode.

++: Select Screen
 ↑↓: Select Item
 Enter: Select
 +/-: Change Opt.
 F1: General Help
 F3: Previous Values
 F9: Optimized Defaults
 F10: Save & Exit
 ESC: Exit

Bios Setup Utility

Advanced

SATA Port5	Not Present	
SATA Mode		[AHCI Mode]
Aggressive Link Power Management		[Enabled]
Port 0 Hot Plug		[Disabled]
Port 1 Hot Plug		[Disabled]
Port 2 Hot Plug		[Disabled]
Port 3 Hot Plug		[Disabled]
Port 4 Hot Plug		[Disabled]
Port 5 Hot Plug		[Disabled]
External SATA Port 0		[Disabled]
External SATA Port 1		[Disabled]
External SATA Port 2		[Disabled]
External SATA Port 3		[Disabled]
External SATA Port 4		[Disabled]
External SATA Port 5		[Disabled]
Staggered Spin-up		[Disabled]
Staggered Spin-up		[Disabled]
Staggered Spin-up		[Disabled]
Staggered Spin-up		[Disabled]
Staggered Spin-up		[Disabled]

AHCI Supports Staggered Spin-up

++: Select Screen
 ↑↓: Select Item
 Enter: Select
 +/-: Change Opt.
 F1: General Help
 F3: Previous Values
 F9: Optimized Defaults
 F10: Save & Exit
 ESC: Exit

☞ **SATA Configuration**

☞ **SATA Port 0/1/2/3/4/5** (Note)

Displays the installed HDD devices information. System will automatically detect HDD type.

☞ **SATA Mode**

Select the on chip SATA type.

IDE Mode: When set to IDE, the SATA controller disables its RAID and AHCI functions and runs in the IDE emulation mode. This is not allowed to access RAID setup utility.

RAID Mode: When set to RAID, the SATA controller enables both its RAID and AHCI functions. You will be allowed access the RAID setup utility at boot time.

AHCI Mode: When set to AHCI, the SATA controller enables its AHCI functionality. Then the RAID function is disabled and cannot be access the RAID setup utility at boot time.

Options available: IDE/RAID/AHCI/Disabled. Default setting is **AHCI Mode**.

☞ **Aggressive Link Power Management**

Enable PCH to aggressively enter link power state.

Options available: Enabled/Disabled. Default setting is **Enabled**.

☞ **Hot Plug (for Serial SATA Port 0/1/2/3/4/5)**

Enable/Disable Hot Plug support for Serial ATA Port 0/1/2/3/4/5.

Options available: Enabled/Disabled. Default setting is **Disabled**.

☞ **External SATA (for Serial SATA Port 0/1/2/3/4/5)**

Enable/Disable External SATA support for Serial ATA Port 0/1/2/3/4/5.

Options available: Enabled/Disabled. Default setting is **Disabled**.

☞ **Straggered Spin Up (for Serial SATA Port 0/1/2/3/4/5)**

On an edge detect from 0 to 1, the PCH starts a COMreset initialization to the device.

Options available: Enabled/Disabled. Default setting is **Disabled**.

(Note) This item will not appear when the SATA mode is set to RAID mode.

2-2-7 SAS Configuration



🔗 SAS Configuration

🔗 SAS Port 0/1/2/3 ^(Note)

Press [Enter] to view the installed HDD devices.

(Note) The number of SATA and SAS devices depends on the PCH SKU.

2-2-8 Info Report Configuration



☞ Info Report Configuration

☞ Post Report

☞ Post Report

Enable/Disable Post Report support.

Options available: Enabled/Disabled. Default setting is **Enabled**.

☞ Error Message Report

☞ Info Error Message

Enable/Disable Info Error Message support.

Options available: Enabled/Disabled. Default setting is **Enabled**.

2-2-9 Super IO Configuration





🔗 Super IO Configuration

🔗 Super IO Chip

Display the model name of Super IO chipset.

🔗 Serial Port 0/1 Configuration

🔗 Serial Port

When enabled allows you to configure the serial port settings. When set to Disabled, displays no configuration for the serial port.

Options available: Enabled/Disabled. Default setting is **Enabled**.

🔗 Device Settings

Displays the Serial Port base I/O address and IRQ.

🔗 Change Settings

Change Serial Port 0/1 device settings. When set to Auto allows the server's BIOS or OS to select a configuration.

Options available for Serial Port 0: Auto/IO=3F8h; IRQ=4/IO=3F8h; IRQ=3,4,5,6,7,10,11,12/IO=2F8h; IRQ=3,4,5,6,7,10,11,12 /IO=3E8h; IRQ=3,4,5,6,7,10,11,12/IO=2E8h; IRQ=3,4,5,6,7,10,11,12.

Options available for Serial Port 1: Auto/IO=3F8h; IRQ=3/IO=3F8h; IRQ=3,4,5,6,7,10,11,12/IO=2F8h; IRQ=3,4,5,6,7,10,11,12 /IO=3E8h; IRQ=3,4,5,6,7,10,11,12/IO=2E8h; IRQ=3,4,5,6,7,10,11,12.

2-2-10 Serial Port Console Redirection

Bios Setup Utility	
Advanced	
COM1 Console Redirection [Enabled] ▶ Console Redirection Settings	Console Redirection Enable or Disable.
COM2 Console Redirection [Enabled] ▶ Console Redirection Settings	
Serial Port for Out-of-Band Management/ Windows Emergency Management Services (EMS) Console Redirection [Enabled] ▶ Console Redirection Settings SDL Switch [Disabled]	++: Select Screen ↑↓: Select Item Enter: Select +/-: Change Opt. F1: General Help F8: Previous Values F9: Optimized Defaults F10: Save & Exit ESC: Exit

Bios Setup Utility	
Advanced	
COM1 Console Redirection Settings	Emulation: ANSI: Extended ASCII char set. VT100: ASCII char set. VT100+: Extends VT100 to support color, function keys, etc. VT-UTF8: Uses UTF8 encoding to map Unicode chars onto 1 or more bytes.
Terminal Type [ANSI] Bits per second [115200] Data Bits [8] Parity [None] Stop Bits [1] Flow Control [None] VT-UTF8 Combo Key Support [Enabled] Recorder Mode [Disabled] Resolution 100x31 [Enabled] Legacy OS Redirection Resolution [80x24] Putty KeyPad [VT100] Redirection After BIOS POST [Always Enable]	
	++: Select Screen ↑↓: Select Item Enter: Select +/-: Change Opt. F1: General Help F8: Previous Values F9: Optimized Defaults F10: Save & Exit ESC: Exit



☞ COM1/COM2/Serial Port for Out-of Band Management / Windows Emergency Management Service (EMS)

☞ Console Redirection ^(Note)

Select whether to enable console redirection for specified device. Console redirection enables users to manage the system from a remote location.

Options available: Enabled/Disabled. Default setting is **Disabled**.

☞ Console Redirection Settings

☞ Terminal Type

Select a terminal type to be used for console redirection.

Options available: VT100/VT100+/ANSI /VT-UTF8.

☞ Bits per second

Select the baud rate for console redirection.

Options available: 9600/19200/57600/115200.

☞ Data Bits

Select the data bits for console redirection.

Options available: 7/8.

☞ Parity

A parity bit can be sent with the data bits to detect some transmission errors.

Even: parity bit is 0 if the num of 1's in the data bits is even.

Odd: parity bit is 0 if num of 1's the data bits is odd.

Mark: parity bit is always 1. Space: Parity bit is always 0.

Mark and Space Parity do not allow for error detection.

Options available: None/Even/Odd/Mark/Space.

(Note) Advanced items prompt when this item is defined.

☞ Stop Bits

Stop bits indicate the end of a serial data packet. (A start bit indicates the beginning). The standard setting is 1 stop bit. Communication with slow devices may require more than 1 stop bit.

Options available: 1/2.

☞ Flow Control^(Note)

Flow control can prevent data loss from buffer overflow. When sending data, if the receiving buffers are full, a 'stop' signal can be sent to stop the data flow. Once the buffers are empty, a 'start' signal can be sent to re-start the flow. Hardware flow control uses two wires to send start/stop signals.

Options available: None/Hardware RTS/CTS.

☞ VT-UTF8 Combo Key Support ^(Note)

Enable/Disable VT-UTF8 Combo Key Support.

Options available: Enabled/Disabled. Default setting is **Enabled**.

☞ Recorder Mode ^(Note)

When this mode enabled, only text will be send. This is to capture Terminal data.

Options available: Enabled/Disabled.

☞ Resolution 100x31 ^(Note)

Enables or disables extended terminal resolution.

Options available: Enabled/Disabled.

☞ Legacy OS Redirection Resolution ^(Note)

On Legacy OS, the number of Rows and Columns supported redirection.

Options available: 80x24/80X25.

☞ Putty KeyPad ^(Note)

Select function FunctionKey and KeyPad on Putty.

Options available: VT100/LINUX/XTERMR6/SCO/ESC/VT400.

☞ Redirection After BIOS POST ^(Note)

This option allows user to enable console redirection after O.S has loaded.

Options available: Always Enable/Boot Loader. Default setting is **Always Enable**.

☞ Out-of-Bnad Mgmt Port

Microsoft Windows Emerency Management Service (EMS) allows for remote management of a Windows Server OS through a serial port.

Options available: COM1/COM2.

☞ SOL Switch

When enabled, COM1 Switch to AST2300 SOL UART.

When disabled, COM1 Switch to IT8728 SOL UART.

Options available: Enabled/Disabled. Default setting is **Disabled**.

(Note) The item is only available for COM1/COM2.

2-2-11 Network Stack



⌄ Network stack

Enable/Disable UEFI network stack.

Options available: Enabled/Disabled. Default setting is **Disabled**.

⌄ Ipv4 PXE Support^(Note)

Enable/Disable Ipv4 PXE feature.

Options available: Enabled/Disabled. Default setting is **Enabled**.

⌄ Ipv6 PXE Support^(Note)

Enable/Disable Ipv6 PXE feature.

Options available: Enabled/Disabled. Default setting is **Enabled**.

⌄ PXE boot wait time

Press the <+> or <-> keys to configure the desired value.

(Note) This item appears when **Network Stack** is set to **Enabled**.

2-2-12 iSCSI Configuration

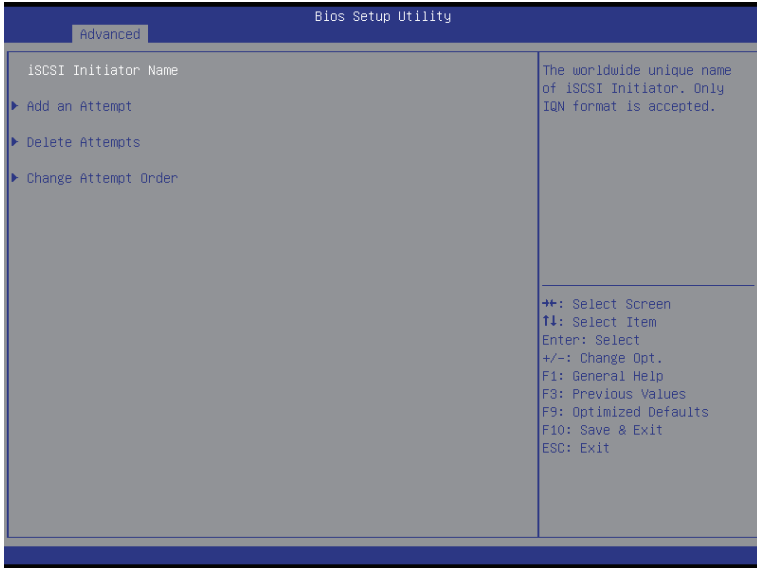

☞ iSCSI Initiator Name

☞ Add an Attempts

Press [Enter] for configuration of advanced items.

☞ Delete Attempts

Press [Enter] for configuration of advanced items.

☞ Change Attempt Order

Press [Enter] for configuration of advanced items.

2-2-13 Intel (R) I350 Gigabit Network Connection

Bios Setup Utility		
Advanced		
PORT CONFIGURATION MENU ▶ NIC Configuration		Configure Boot Protocol, Wake on LAN, Link Speed, and VLAN.
Blink LEDs 0		
PORT CONFIGURATION INFORMATION		++: Select Screen ↑↓: Select Item Enter: Select +/-: Change Opt. F1: General Help F3: Previous Values F9: Optimized Defaults F10: Save & Exit ESC: Exit
UEFI Driver:	Intel(R) PRO/1000 5.5.23 PCI	
Adapter PBA:	130529-003	
Chip Type	Intel i350	
PCI Device ID	1521	
Bus:Device:Function	07:00:00	
Link Status	[Disconnected]	
MAC Address	94:DE:80:17:B7:A2	
Virtual MAC Address	94:DE:80:17:B7:A2	

Bios Setup Utility		
Advanced		
Link Speed	[Auto Negotiated]	Specifies the port speed used for the selected boot protocol.
Wake On LAN	[Enabled]	
		++: Select Screen ↑↓: Select Item Enter: Select +/-: Change Opt. F1: General Help F3: Previous Values F9: Optimized Defaults F10: Save & Exit ESC: Exit

☞ **PORT CONFIGURATION MENU**

☞ **NIC Configuration**

Press [Enter] for configuration of advanced items.

☞ **Blink LEDs (range 0-15 seconds)**

Blink LEDs for the specified duration (up to 15 seconds).

Press the numeric keys to input the desired value.

☞ **PORT CONFIGURATION INFORMATION**

☞ **UEFI Driver**

Display the UEFI driver information.

☞ **Adapter PBA**

Display the Adapter PBA information.

☞ **Chip Type**

Display the Chip type.

☞ **PCI Device ID**

Display the PCI device ID.

☞ **Bus:Device:Function**

Display the number of Bus/Device/Function

☞ **Link Status**

Display the link status.

☞ **MAC Address**

Display the Factory MAC address information.

☞ **Virtual MAC Address**

Display the virtual MAC address information.

☞ **Link Speed**

Change link speed duplex for current port.

Options available: AutoNeg/10Mbps Half/10Mbps Half/10Mbps Full/100Mbps Full.

Default setting is **AutoNegotiated**.

☞ **Wake On LAN**

Enable/Disable Wake On LAN feature.

Options available: Enabled/Disabled. Default setting is **Enabled**.

2-3 Chipset Menu

The Chipset menu display submenu options for configuring the function of North Bridge and South Bridge. Select a submenu item, then press Enter to access the related submenu screen.

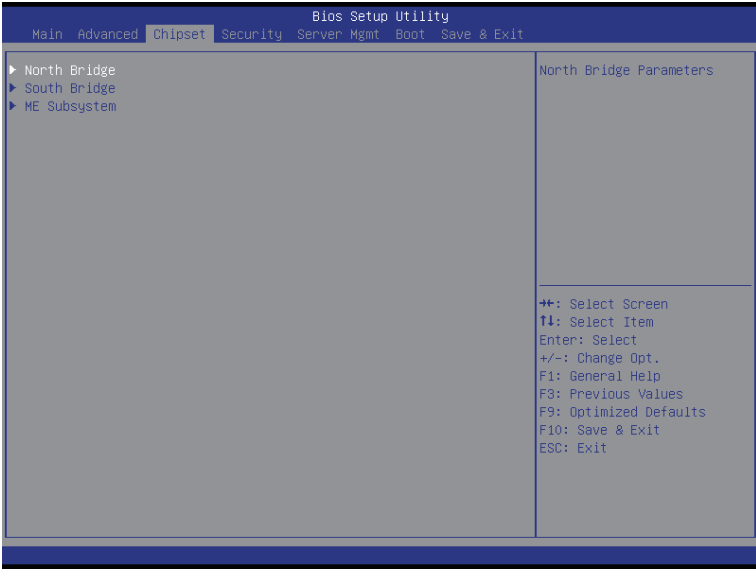

2-3-1 North Bridge

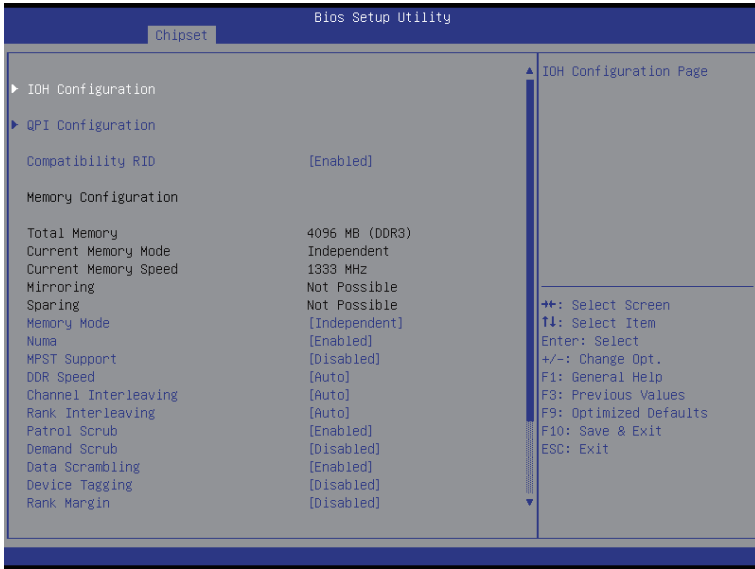

☞ IOH Configuration

Press [Enter] for configuration of advanced items.

☞ QPI Configuration

Press [Enter] for configuration of advanced items.

☞ Compatibility RID

Enable/Disable Compatibility RID function.

Options available: Enabled/Disabled. Default setting is **Enabled**.

☞ Memory Configuration

☞ Total Memory

Displays the total capacity of the installed memory.

☞ Current Memory Mode

Displays the current memory mode. Memory mode can be determined in **Memory Mode** item.

☞ Current Memory Speed

Displays the current memory speed.

☞ Mirroring/Sparing

Displays the current support memory mode.

☞ Memory Mode

Determine the memory mode.

When set to Independent mode, all DIMMs are available to the operation system.

When set to Mirroring mode, the motherboard maintains two identical (redundant) copies of all data in memory.

When set to Lockstep mode, the motherboard uses two areas of memory to run the same set of operations in parallel.

When set to Sparing mode, a preset threshold of correctable errors is used to trigger fail-over.

The spare memory is put online and used as active memory in place of the failed memory.

Options available: Independent /Mirroring/ Lockstep/Sparing.

☞ Numa

Enable/Disable Numa function.

Options available: Enabled/Disabled. Default setting is **Enabled**.

☞ MPST

Enable/Disable MPST function.

Options available: Enabled/Disabled. Default setting is **Disabled**.

☞ DDR Speed

Configure the DDR Speed.

Options available: Auto/Force DDR3 800/Force DDR3 1066/Force DDR3 1333/Force DDR3 1600/Force DDR3 1866. Default setting is **Auto**.

☞ Channel interleaving

Configure DDR Channel Interleaving.

Options available: Auto/1 Way/2 Way/3 Way/4 Way. Default setting is **Auto**.

☞ Rank interleaving

Configure DDR Rank Interleaving. This improves memory performance by masking the refresh cycles of each memory bank. The Rank Interleaving works between different physical banks.

Options available: Auto/1 Way/2 Way/3 Way/4 Way. Default setting is **Auto**.

☞ **Patrol Scrub**

Enable/Disable Patrol Scrub function.

Options available: Enabled/Disabled. Default setting is **Enabled**.

☞ **Demand Scrub**

Enable/Disable Demand Scrub function.

Options available: Enabled/Disabled. Default setting is **Disabled**.

☞ **Data Scrambling**

Enable/Disable Data Scrambling function.

Options available: Enabled/Disabled. Default setting is **Enabled**.

☞ **Device Tagging**

Enable/Disable Device Tagging function.

Options available: Enabled/Disabled. Default setting is **Disabled**.

☞ **Rank Margin**

Enable/Disable Rank Margin function.

Options available: Enabled/Disabled. Default setting is **Disabled**.

☞ **Thermal Thortting**

Configure the Thermal Thortting.

Options available: Disabled/OLTT/CLTT. Default setting is **CLTT**.

☞ **OLTT Peak BW %**

Press the numeric keys to increase or decrease the desired values.

☞ **Altitude**

Configure the Altitude value.

Options available: Auto/300 M/900 M/1500 M/3000 M. Default setting is **3000 M**.

☞ **Enforce DIMM**

To enforce POR function. When disabled, the system will enforce 1600MHz LRDIMM.

Options available: Enforce EN/Stretch EN/Enforce DIS. Default setting is **Enforce DIS**.

☞ **DIMM Information**

Press [Enter] for configuration to view installed DIMM information.

2-3-1-1 IOH Configuration

Bios Setup Utility		
Chipset		
▶ Intel(R) VT for Directed I/O Configuration		Intel(R) VT for Directed I/O Configuration
Intel(R) I/OAT	[Disabled]	
DCA Support	[Enabled]	
VGA Priority	[Offboard]	
TargetVGA	Vga From CPU 0	
Gen3 Equalization WA's	[Disabled]	
IOH Resource Selection Type	[Auto]	
No Snoop Optimization	[VC1]	
MMIOH Size	[64G]	
MMCFG BASE	[0x80000000]	
		++: Select Screen ↑↓: Select Item Enter: Select +/-: Change Opt. F1: General Help F8: Previous Values F9: Optimized Defaults F10: Save & Exit ESC: Exit

Bios Setup Utility		
Chipset		
Intel(R) VT-d	[Enabled]	Enable/Disable Intel(R) Virtualization Technology for Directed I/O.
		++: Select Screen ↑↓: Select Item Enter: Select +/-: Change Opt. F1: General Help F8: Previous Values F9: Optimized Defaults F10: Save & Exit ESC: Exit

- ☞ **IOH Configuration**
- ☞ **Intel(R) VT for Directed I/O Configuration**
Press [Enter] for configuration of advanced items.
- ☞ **Intel(R) I/OAT (Intel I/O Acceleration Technology)**
Enable/Disable Intel I/OAT function.
Options available: Enabled/Disabled. Default setting is **Disabled**.
- ☞ **DCA Support (Direct Cache Access)**
Enable/Disable Intel DCA Support function.
Options available: Enabled/Disabled. Default setting is **Disabled**.
- ☞ **VGA Priority**
Define the display device priority.
Options available: Onboard/Offboard. Default setting is **Offboard**.
- ☞ **TargetVGA**
Display the Target VGA support information.
- ☞ **Gen3 Equalization WA's**
Enable/Disable the support for Gen3 Equalization Workaround.
Options available: Enabled/Disabled. Default setting is **Disabled**.
- ☞ **IOH Resource Selection Type**
Configure IOH Resource Selection Type.
Options available: Auto/Manual. Default setting is **Auto**.
- ☞ **No Snoop Optimization**
Options VC0/VCP/VC1. Default setting is **VC1**.
- ☞ **MMCFG Size (Size of the Memory Mapped Configuration Space)**
Options available: 1G/2G/4G/8G/16G/32G/64G. Default setting is **64G**.
- ☞ **MMCFGBASE (Base address of the Memory Mapped Configuration Space)**
Options available: 0x80000000/0xA0000000/0xC0000000/0x40000000. Default setting is **0x80000000**.
- ☞ **Intel(R) VT-d**
Enable/Disable Intel VT-d Technology function.
Options available: Enabled/Disabled. Default setting is **Enabled**.

2-3-1-2 QPI Configuration

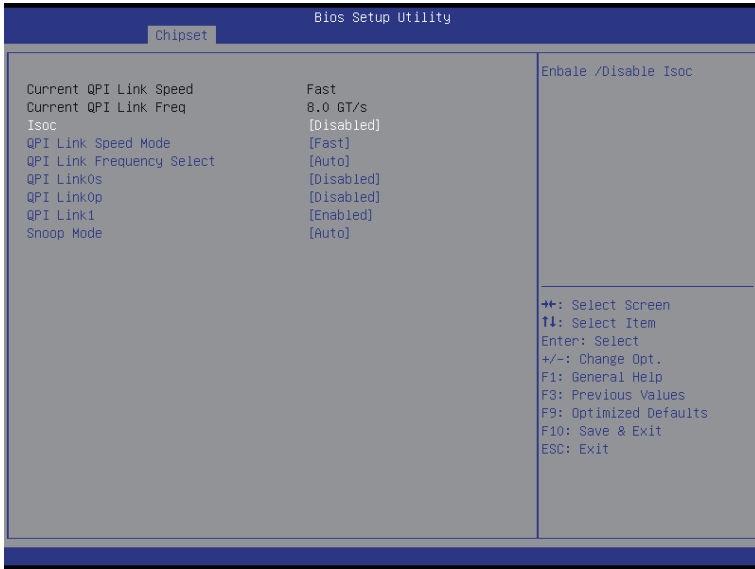

- ☞ **Current QPI Link Speed/ Current QPI Link Freq**
Displays the current QPI Link Speed and Frequency information.
- ☞ **Isoc**
Enable/Disable Isoc.
Options available: Enabled/Disabled. Default setting is **Disabled**.
- ☞ **QPI Link Speed Mode**
Configure QPI Link Speed mode.
Options available: Fast/Slow. Default setting is **Fast**.
- ☞ **QPI Link Frequency Select**
Configure QPI Link Frequency.
Options available: Auto/6.4 GT/s/7.2 GT/s/8.6 GT/s. Default setting is **Auto**.
- ☞ **QPI Link0s**
Options available: Enabled/Disabled. Default setting is **Disabled**.
- ☞ **QPI Link0p**
Options available: Enabled/Disabled. Default setting is **Disabled**.
- ☞ **QPI Link1**
Options available: Enabled/Disabled. Default setting is **Enabled**.
- ☞ **Snoop Mode**
Options available: Auto/Disabled. Default setting is **Auto**.

2-3-1-3 DIMM Information

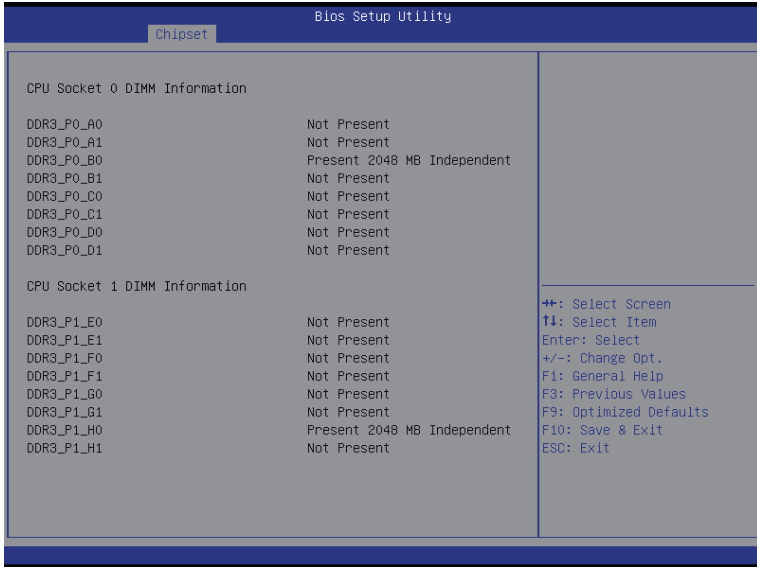

☞ **CPU Socket 0/1 DIMM Information**

☞ **CPU Socket 0:**

☞ **DDR3_P0_A0/DDR3_P0_A1/DDR3_P0_B0/DDR3_P0_B1/
DDR3_P0_C0/DDR3_P0_C1/DDR3_P0_D0/DDR3_P0_D1 Status**

The size of memory installed on each of the DDR3 slots.

☞ **CPU Socket 1:**

☞ **DDR3_P1_E0/DDR3_P1_E1/DDR3_P1_F0/DDR3_P1_F1/
DDR3_P1_G0/DDR3_P1_G1/DDR3_P1_H0/DDR3_P1_H1 Status**

The size of memory installed on each of the DDR3 slots.

2-3-2 South Bridge Configuration

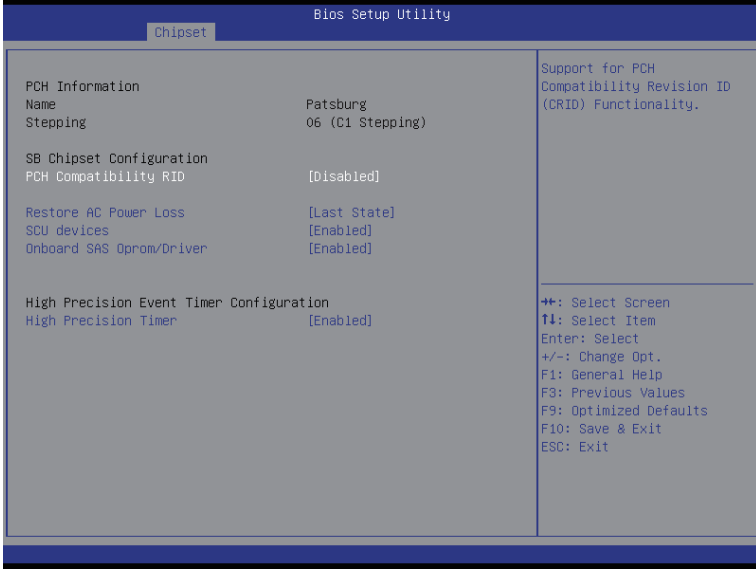

☞ PCH Information

☞ Name/Stepping Information

Displays the name and stepping information of the south bridge.

☞ SB Chipset Configuration

☞ PCH Compatibility RID

Enable/Disable PCH Compatibility RID support.

Options available: Enabled/Disabled. Default setting is **Disabled**.

☞ USB WakeOnDev insertion

Enable/Disable USB Device WakeOn support.

Options available: Enabled/Disabled. Default setting is **Disabled**.

☞ Restore on AC Power Loss ^(Note)

Defines the power state to resume to after a system shutdown that is due to an interruption in AC power. When set to Last State, the system will return to the active power state prior to shutdown. When set to Stay Off, the system remains off after power shutdown.

Options available: Last State/Stay Off/Power On. The default setting depends on the BMC setting.

☞ SCU Devices

Enable/Disable Patsburg SCU device.

Options available: Enabled/Disabled. Default setting is **Disabled**.

☞ Onboard SAS Oprom/Driver

Enable/Disable onboard SAS option ROM.

Options available: Enabled/Disabled. Default setting is **Enabled**.

(Note) When the power policy is controlled by BMC, please wait for 15-20 seconds for BMC to save the last power state.

☞ **High Precision Event Timer Configuration**

☞ **High Precision Event Timer**

Enable/Disable High Precision Event Timer.

Options available: Enabled/Disabled. Default setting is **Enabled**.

2-3-3 Intel ME Subsystem

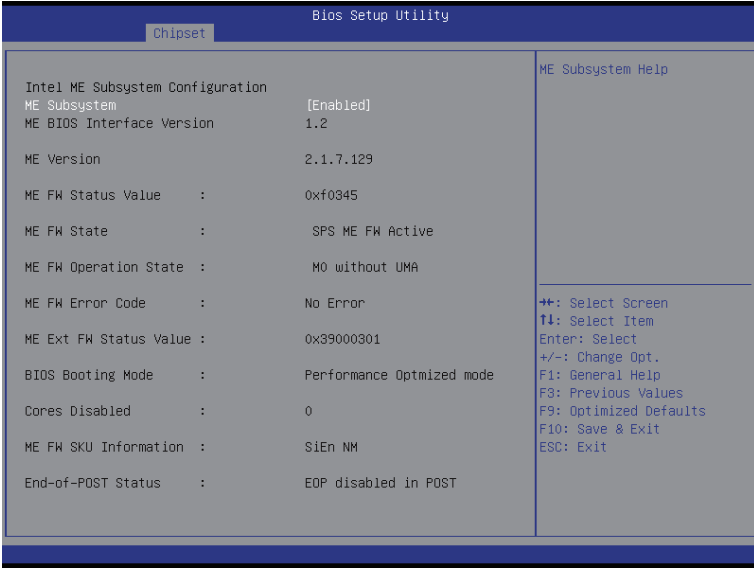

ME Subsystem Configuration

Enable/Disable ME subsystem configuration.

Options available: Enabled/Disabled. Default setting is **Enabled**.

2-4 Security Menu

The Security menu allows you to safeguard and protect the system from unauthorized use by setting up access passwords.

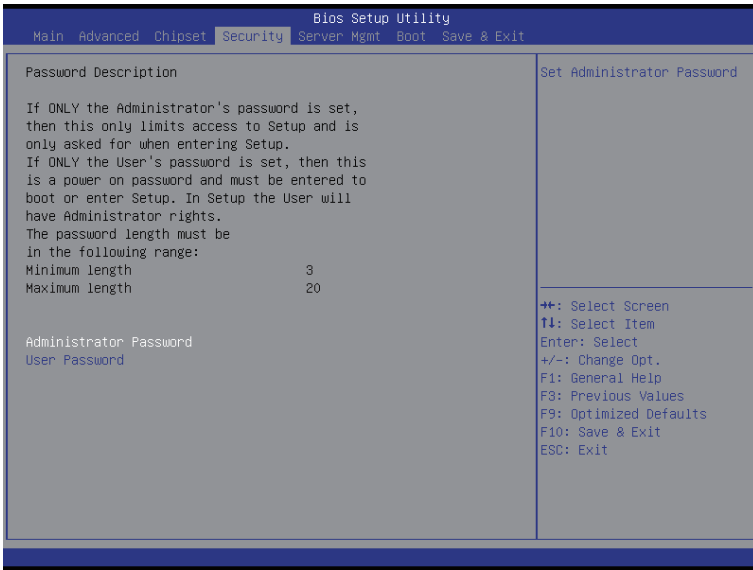

There are two types of passwords that you can set:

- **Administrator Password**
Entering this password will allow the user to access and change all settings in the Setup Utility.
- **User Password**
Entering this password will restrict a user's access to the Setup menus. To enable or disable this field, a Administrator Password must first be set. A user can only access and modify the System Time, System Date, and Set User Password fields.

⌄ Administrator Password

Press Enter to configure the Administrator password.

⌄ User Password

Press Enter to configure the user password.

2-5 Server Management Menu

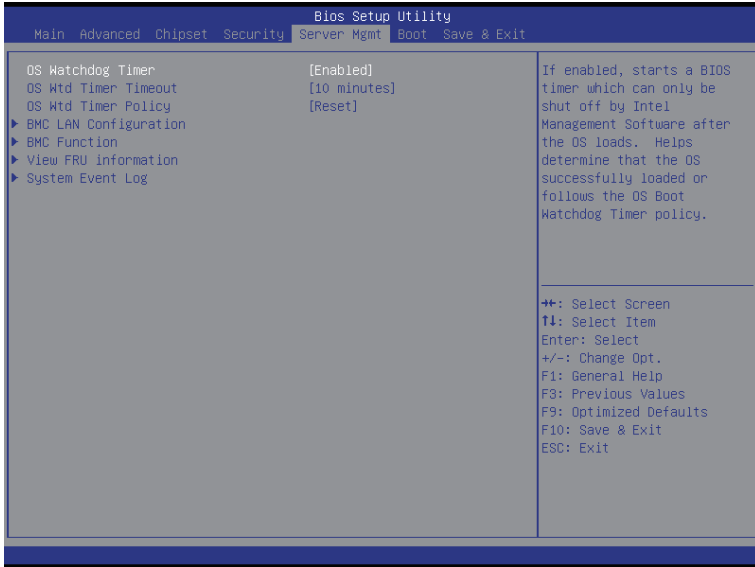

☞ OS Watchdog Timer

Enable/Disable OS Watchdog Timer function.

Options available: Enabled/Disabled. Default setting is **Disabled**.

☞ OS Wtd Timer Timeout

Configure OS Watchdog Timer.

Options available: 5 minutes/10 minutes/15 minutes/20 minutes. Default setting is **10 minutes**.

☞ OS Wtd Timer Policy

Configure OS Watchdog Timer Policy.

Options available: Reset/Do Nothing/Power Down. Default setting is **Reset**.

☞ BMC LAN Configuration

BMC LAN Configuration. Press Enter to access the related submenu.

☞ BMC Function

BMC related function configuration. Press Enter to access the related submenu.

☞ View FRU information

The FRU information submenu is a simple display page for basic system ID information, as well as system product information. Items on this window are non-configurable.

☞ System Event Log

Displays Event Log advanced settings. Press Enter to access the related submenu.

2-5-1 BMC LAN Configuration

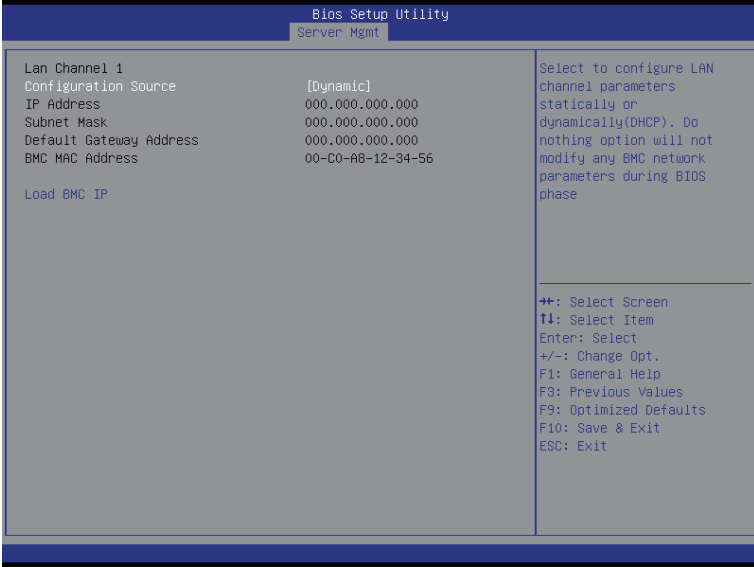

☞ Lan Channel 1

☞ Configuration Source

Select to configure LAN channel parameters statically or dynamically (DHCP). Do nothing option will not modify any BMC network parameters during BIOS phase.

Options available: Static/Dynamic/Do Nothing.

☞ IP Address

Display IP Address information.

☞ Subnet Mask

Display Subnet Mask information.

Please note that the IP address must be in three digitals, for example, 192.168.000.001.

☞ Default Gateway Address

Display Default Gateway Address information.

☞ Load BMC IP

Press [Enter] to load BMC IP.

2-5-2 BMC Function

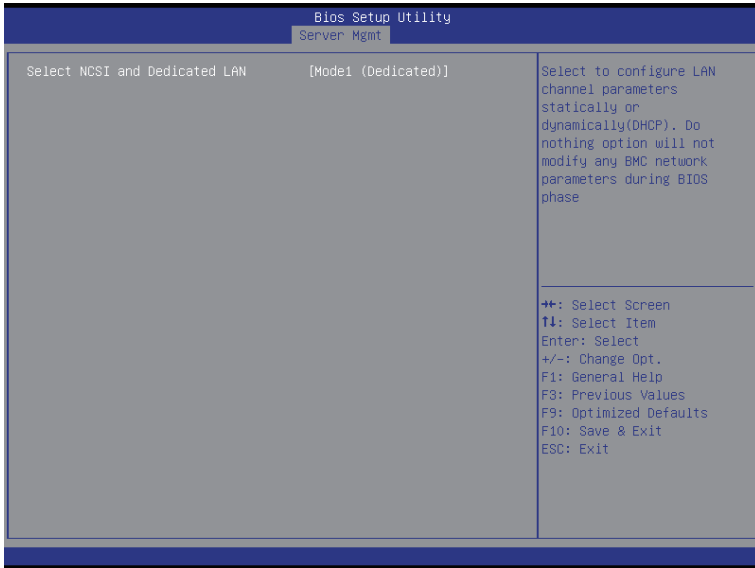

🔗 Select NCSI and Dedicated LAN

Switch NCSI and dedicated LAN and send KCS command.

Options available: Mode2(NCSI)/ Mode1 (Dedicated). Default setting is **Mode1 (Dedicated)**.

2-5-3 View FRU Information

The View FRU Information menu is a simple display page for basic system ID information, as well as System product information. Items on this window are non-configurable.

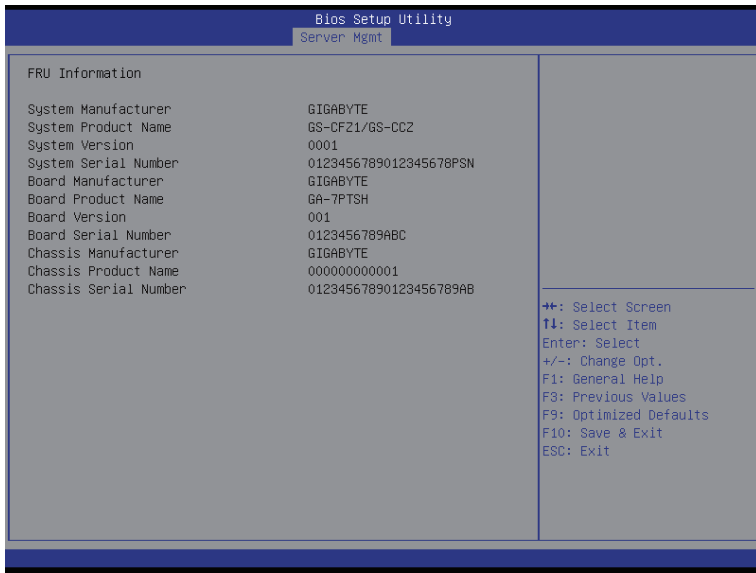

2-5-4 System Event Log

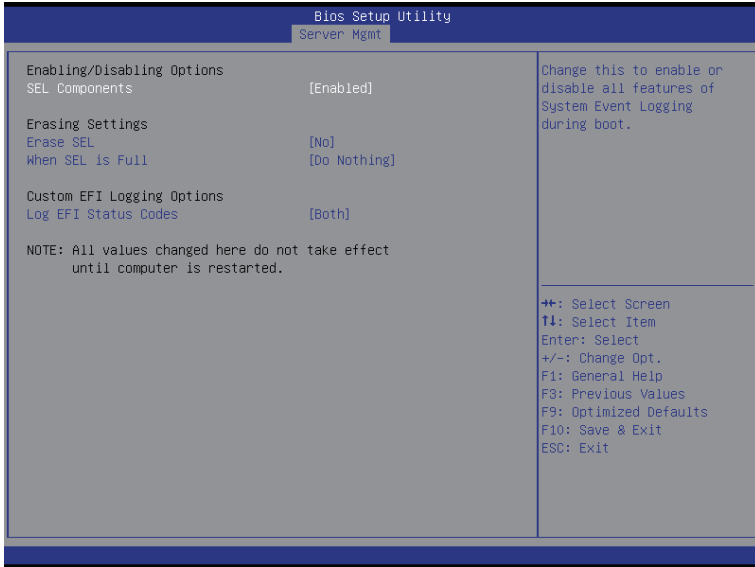

☞ Enabling/Disabling Options

☞ SEL Components

Change this to enable or disable all features of System Event Logging during boot.
Options available: Enabled/Disabled. Default setting is **Enabled**.

☞ Erasing Settings

☞ Erasing SEL

Choose options for erasing SEL.

Options available: No/Yes, On next reset/Yes, On every reset. Default setting is **No**.

☞ When SEL is Full

Choose options for reactions to a full SEL.

Options available: Do Nothing/Erase Immediately. Default setting is **Do Nothing**.

☞ Custom EFI Logging Options

☞ Log EFI Status Codes

Enable/Disable the logging of EFI Status Codes (if not already converted to legacy).

Options available: Disabled/Both/Error code/Progress code. Default setting is **Both**.

2-6 Boot Menu

The Boot menu allows you to set the drive priority during system boot-up. BIOS setup will display an error message if the legacy drive(s) specified is not bootable.

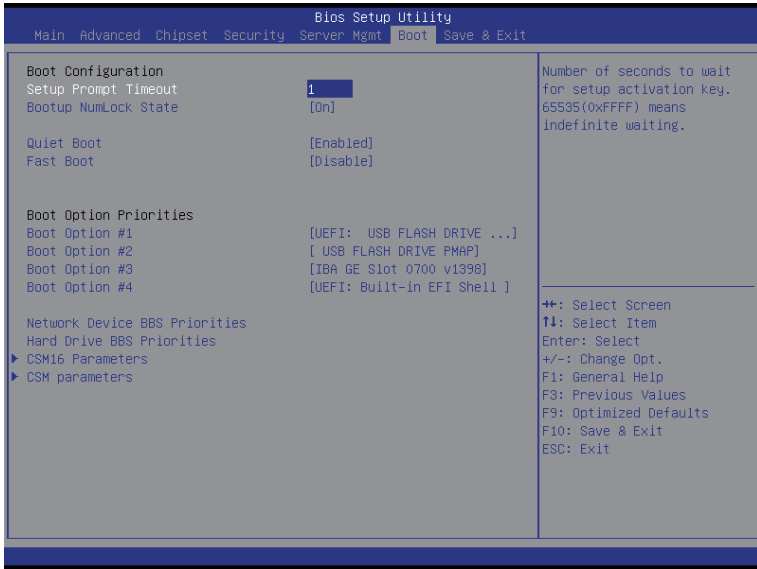

☞ Boot Configuration

☞ Setup Prompt Timeout

Number of seconds to wait for setup activation key. 65535(0xFFFF) means indefinite waiting." Press the numeric keys to input the desired value.

☞ Bootup NumLock State

Enable or Disable Bootup NumLock function.
Options available: On/Off. Default setting is **On**.

☞ Quiet Boot

Enable/Disable showing the manufacturer's logo during POST.
Options available: Enabled/Disabled. Default setting is **Enabled**.

☞ Fast Boot

This BIOS feature allows you to decrease the time it takes to boot up the system by skipping certain booting procedures.
Options available: Enabled/Disabled. Default setting is **Disabled**.

☞ **Boot Priority Order**

☞ **Boot Option #1/#2/#3/#4**

Press Enter to configure the boot priority.

By default, the server searches for boot devices in the following sequence:

1. UEFI device.
2. Hard drive.
3. Network device.
4. Removable device

☞ **Network Device BBS Priorities**

Press Enter to configure the boot priority.

☞ **Hard Drive BBS Priorities**

Press Enter to configure the boot priority.

☞ **CSM16 Parameters**

Press Enter to configure the CSM16 parameters.

☞ **CSM Parameters**

Press Enter to configure the CSM parameters.

2-6-1 CSM16 Parameters

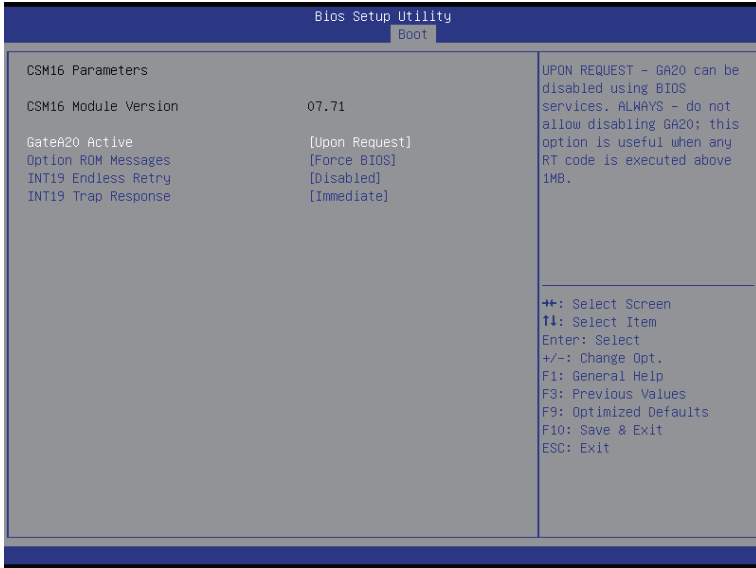

☞ CSM16 Parameters

☞ CSM16 Module Version

Display CSM Module version information.

☞ Gate20 Active

Upon Request: GA20 can be disabled using BIOS services.

Always: Do not allow disabling GA20; this option is useful when any RT code is executed above 1MB.

Options available: Upon Request/Always. Default setting is **Upon Request**.

☞ Option ROM Messages

Option ROM Messages.

Options available: Force BIOS/Keep Current. Default setting is **Force BIOS**.

☞ INT19 Endless Retry

Enabled: Allowed headless retry boot

Options available: Enabled/Disabled. Default setting is **Disabled**.

☞ INT19 Trap Response

BIOS reaction on INT19 trapping by Option ROM

Immediate: execute the trap right away.

Postpone: execute the trap during legacy boot.

Options available: Immediate/Postpone. Default setting is **Immediate**.

2-6-2 CSM Parameters

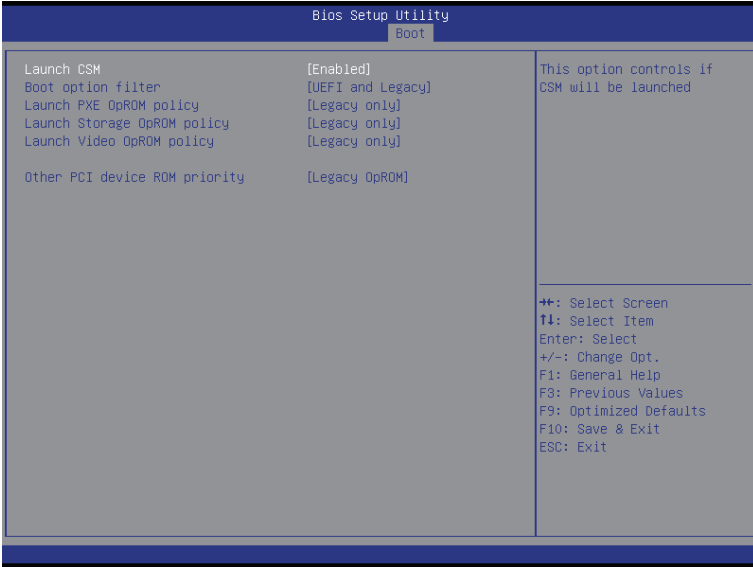

☞ CSM parameters

Press Enter to configure the advanced items.

☞ Launch CSM (Compatibility Support Module)

Enable/Disable Compatibility Support Module (CSM) launch.

Options available: Enabled/Disabled. Default setting is **Enabled**.



- The following five items appear and are configurable when the **Launch CSM** is set to **Enabled**.
- If the **Launch CSM** is set to **Disabled**, the following five items will not be able to support Legacy mode.

☞ Boot option filter

Determines which devices system will boot to.

Options available: UEFI and Legacy/Legacy only/UEFI only. Default setting is **UEFI and Legacy**.

☞ Launch PXE OpROM policy

Determines which devices system will boot to.

Options available: UEFI only/Legacy only. Default setting is **Legacy only**.

☞ Launch Storage OpROM policy

Determines which devices system will boot to.

Options available: Do not launch/UEFI only/Legacy only. Default setting is **Legacy only**.

☞ Launch Video OpROM policy

Determines which devices system will boot to.

Options available: Do not launch/UEFI only/Legacy only/Legacy first. Default setting is **Legacy only**.

☞ Other PCI device ROM priority

For PCI devices other than Network, Mass storage or Video device, defines which OpROM to launch.

Options available: UEFI OpROM/Legacy OpROM. Default setting is **Legacy OpROM**.

2-7 Exit Menu

The Exit menu displays the various options to quit from the BIOS setup. Highlight any of the exit options then press **Enter**.

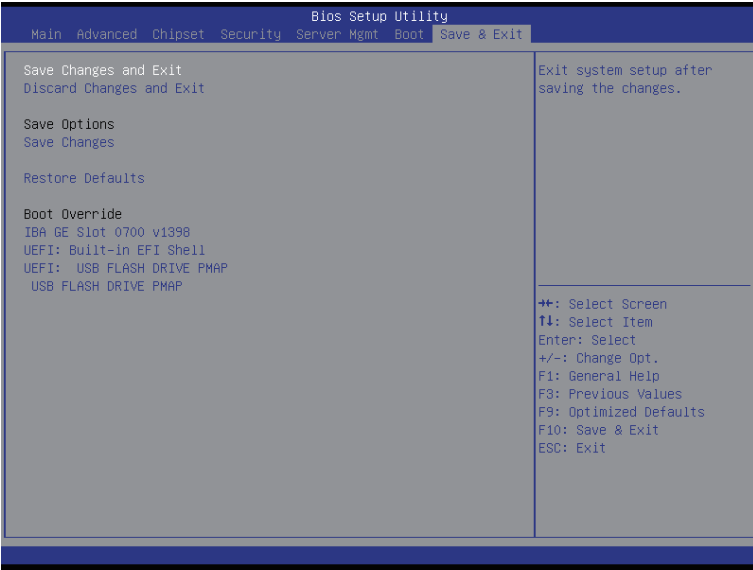

☞ **Save Changes and Exit**

Saves changes made and close the BIOS setup.

Options available: Yes/No.

☞ **Discard Changes and Exit**

Discards changes made and close the BIOS setup.

Options available: Yes/No.

☞ **Save Options**

☞ **Save Changes**

Saves changes made in the BIOS setup.

Options available: Yes/No.

☞ **Restore Defaults**

Loads the default settings for all BIOS setup parameters. Setup Defaults are quite demanding in terms of resources consumption. If you are using low-speed memory chips or other kinds of low-performance components and you choose to load these settings, the system might not function properly.

Options available: Yes/No.

☞ **Boot Override**

Press Enter to configure the device as the boot-up drive.

☞ **UEFI: Built-in in EFI Shell**

Press <Enter> on this item to Launch EFI Shell from filesystem device.

2-8 BIOS Beep Codes

# of Beeps	Description
1	Invalid password
2	Recovery started
4	S3 Resume failed
4	DXE IPL was not found
5	No Console Input/Output Devices are found
6	Flash update is failed

2-9 BIOS Recovery Instruction

The system has an embedded recovery technique. In the event that the BIOS becomes corrupt the boot block can be used to restore the BIOS to a working state. To restore your BIOS, please follow the instructions listed below:

Recovery Instruction:

1. Change xxx.ROM to amiboot.rom.
2. Copy amiboot.rom and AFUDOS.exe to USB diskette.
3. Setting BIOS Recovery jump to enabled status.

BIOS Recovery Jumper

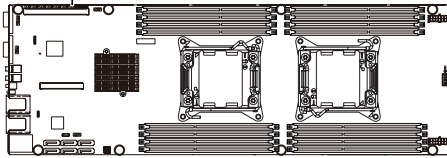

4. Boot into BIOS recovery.
5. Run Proceed with flash update.
6. BIOS update.

