

# **GA-7PESH1**

# **GA-7PESH2**

Dual LGA2011 sockets motherboard for Intel® E5-2600 series processors

## **User's Manual**

Rev. 1002

## **Copyright**

© 2012 GIGA-BYTE TECHNOLOGY CO., LTD. All rights reserved.

The trademarks mentioned in this manual are legally registered to their respective owners.

## **Disclaimer**

Information in this manual is protected by copyright laws and is the property of GIGABYTE.

Changes to the specifications and features in this manual may be made by GIGABYTE without prior notice. No part of this manual may be reproduced, copied, translated, transmitted, or published in any form or by any means without GIGABYTE's prior written permission.

## **Documentation Classifications**

In order to assist in the use of this product, GIGABYTE provides the following types of documentations:

- For quick set-up of the product, read the Quick Installation Guide included with the product.
- For detailed product information, carefully read the User's Manual.

For product-related information, check on our website at:

<http://www.gigabyte.com>

# Table of Contents

Box Contents .....	5
GA-7PESH1/7PESH2 Motherboard Layout .....	6
Block Diagram .....	9
Chapter 1 Hardware Installation .....	10
1-1 Installation Precautions .....	10
1-2 Product Specifications .....	11
1-3 Installing the CPU and CPU Cooler .....	13
1-3-1 Installing the CPU .....	13
1-3-2 Installing the CPU Cooler .....	15
1-4 Installing the Memory .....	16
1-4-1 Four Channel Memory Configuration .....	16
1-4-2 Installing a Memory .....	17
1-4-3 DIMM Population Table .....	17
1-5 Back Panel Connectors .....	18
1-6 Internal Connectors .....	20
1-7 Jumper Setting .....	31
Chapter 2 BIOS Setup .....	36
2-1 The Main Menu .....	38
2-2 Advanced Menu .....	40
2-2-1 PCI Subsystem Settings .....	41
2-2-1-1 PCI Express Settings .....	43
2-2-2 Runtime Error Logging .....	45
2-2-3 CPU Configuration .....	46
2-2-3-1 CPU Power Management Configuration .....	49
2-2-4 USB Configuration .....	51
2-2-5 SATA Configuration .....	52
2-2-6 Info Report Configuration .....	54
2-2-7 Super IO Configuration .....	55
2-2-8 Serial Port Console Redirection .....	57
2-2-9 Network Stack .....	60
2-2-10 Intel (R) I350 Gigabit Network Connection .....	61
2-3 Chipset Menu .....	63
2-3-1 North Bridge .....	64
2-3-1-1 IOH Configuration .....	67
2-3-1-2 QPI Configuration .....	69
2-3-1-3 DIMM Information .....	70

2-3-2	South Bridge Configuration .....	71
2-3-3	Intel ME Subsystem.....	72
2-4	Security Menu .....	73
2-4-1	Secure Boot menu (Optional).....	74
2-4-1-1	Image Execution Policy .....	75
2-4-1-2	Key Management .....	76
2-5	Server Management Menu.....	78
2-5-1	BMC LAN Configuration .....	79
2-5-2	Gbt BMC Function .....	80
2-5-3	View FRU Information .....	81
2-5-4	System Event Log .....	82
2-6	Boot Menu.....	83
2-6-1	CSM16 Parameters .....	85
2-6-2	CSM Parameters .....	86
2-7	Exit Menu .....	88
Chapter 3	Appendix .....	89
3-1	Regulatory Statements.....	89

## Box Contents

- Motherboard
- Driver CD
- Two SATA cables
- I/O Shield

- The box contents above are for reference only and the actual items shall depend on the product package you obtain. The box contents are subject to change without notice.
- The motherboard image is for reference only.

# GA-7PESH1/7PESH2 Motherboard Layout

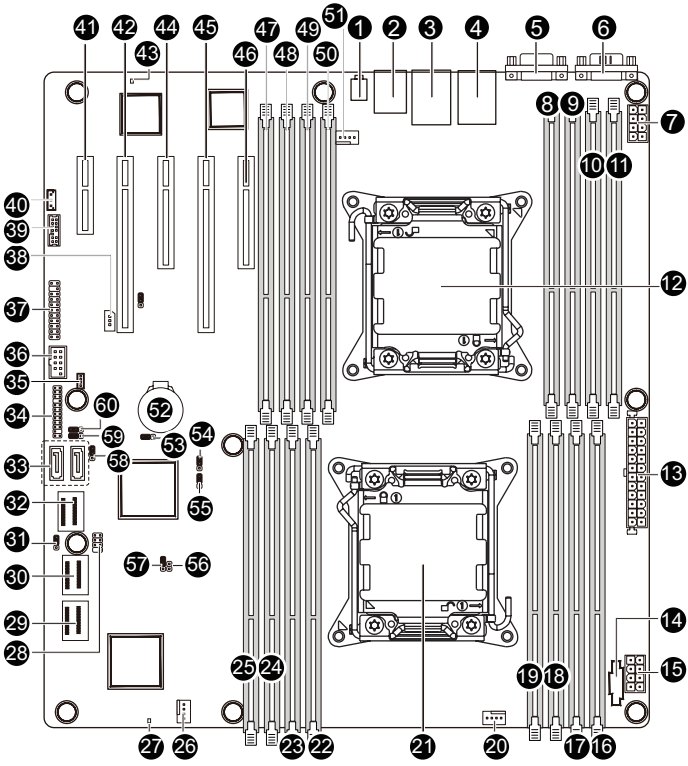

Item	Code	Description
1	SW1	ID switch
2	MLAN (GA-7PESH1)	BMC Management LAN port
	USB_MLAN (GA-7PESH2)	BMC Management LAN port (top) / USB ports (bottom)
3	USB_LAN1 (GA-7PESH1)	LAN1 port (top) / USB ports (bottom)
	GLAN1 (GA-7PESH2)	LAN1 port
4	USB_LAN2 (GA-7PESH1)	LAN2 port (top) / USB ports (bottom)
	GLAN2 (GA-7PESH2)	LAN2 port
5	VGA_1	VGA port
6	COM1	Serial port
7	P12V_AUX2	8 pin power connector
8	DDR3_P1_H1	Channel H slot 1 (for secondary CPU)
9	DDR3_P1_H0	Channel H slot 0 (for secondary CPU)
10	DDR3_P1_G1	Channel G slot 1 (for secondary CPU)
11	DDR3_P1_G0	Channel G slot 0 (for secondary CPU)
12	CPU1	Intel LGA2011 socket (Secondary CPU)
13	ATX1	24-pin power connector
14	PWR_DET1	PM Bus connector
15	P12V_AUX1	8 pin power connector
16	DDR3_P0_A0	Channel A slot 0 (for primary CPU)
17	DDR3_P0_A1	Channel A slot 1 (for primary CPU)
18	DDR3_P0_B0	Channel B slot 0 (for primary CPU)
19	DDR3_P0_B1	Channel B slot 1 (for primary CPU)
20	CPU0_FAN	CPU0 fan cable connector
21	CPU0	Intel LGA2011 socket (Primary CPU)
22	DDR3_P0_D1	Channel D slot 1 (for primary CPU)
23	DDR3_P0_D0	Channel D slot 0 (for primary CPU)
24	DDR3_P0_C1	Channel C slot 1 (for primary CPU)
25	DDR3_P0_C0	Channel C slot 0 (for primary CPU)
26	SYS_FAN2	System fan cable connector
27	LED2	LSI firmware readiness LED
28	SATA_SGPIO	SATA SGPIO connector
29	MINI_CN3	Mini SAS cable connector
30	MINI_CN2	Mini SAS cable connector
31	FLASH_DP1	Flash descriptor security jumper
32	MINI_CN1	Mini SAS cable connector (SATA 3.0Gb/s signal)
33	SATA0/1	SATA 6.0Gb/s connectors
34	BP_1	HDD back plane connector
35	SYS_FAN1	System fan cable connector
36	FRONT_USB	Front USB connector
37	F_PANEL1	Front panel connector
38	IPMB1	IPMB connector
39	TPM_1	TPM connector
40	SKU_KEY1	PBG A SKU Select connector
41	PCIE_5	PCI-E slot 5 (x4 slot / x1 bus)

42	PCIE_4	PCI-E slot 4 (x16 slot / x8 bus)
43	BMC_LED1	BMC firmware readiness LED
44	PCIE_3	PCI-E slot 3 (x8 slot / x4 bus)
45	PCIE_2	PCI-E slot 2 (x16 slot/x16 bus)
46	PCIE_1	PCI-E slot 1 (x8 slot / x4 bus)
47	DDR3_P1_E0	Channel E slot 0 (for secondary CPU)
48	DDR3_P1_E1	Channel E slot 1 (for secondary CPU)
49	DDR3_P1_F0	Channel F slot 0 (for secondary CPU)
50	DDR3_P1_F1	Channel F slot 1 (for secondary CPU)
51	CPU1_FAN	CPU1 fan cable connector
52	BAT1	Battery
53	CLR_CMOS1	Clear CMOS jumper
54	BIOS_WP1	BIOS write protect jumper
55	SSB_ME1	ME recovery jumper
56	JP1	Chassis intrusion jumper
57	PASSWORD1	Clear password jumper
58	BIOS_RVCR1	BIOS recovery jumper
59	SATA_DOM0	SATA0 port DOM support jumper
60	SATA_DOM1	SATA1 port DOM support jumper



**CAUTION!** If a SATA type hard drive is connected to the motherboard, please ensure the jumper is closed and set to **2-3 pins** (Normal mode), in order to reduce any risk of hard disk damage. Please refer to Page 33 for SATA\_DOM0 and SATA\_DOM1 jumper setting instruction.



# Block Diagram

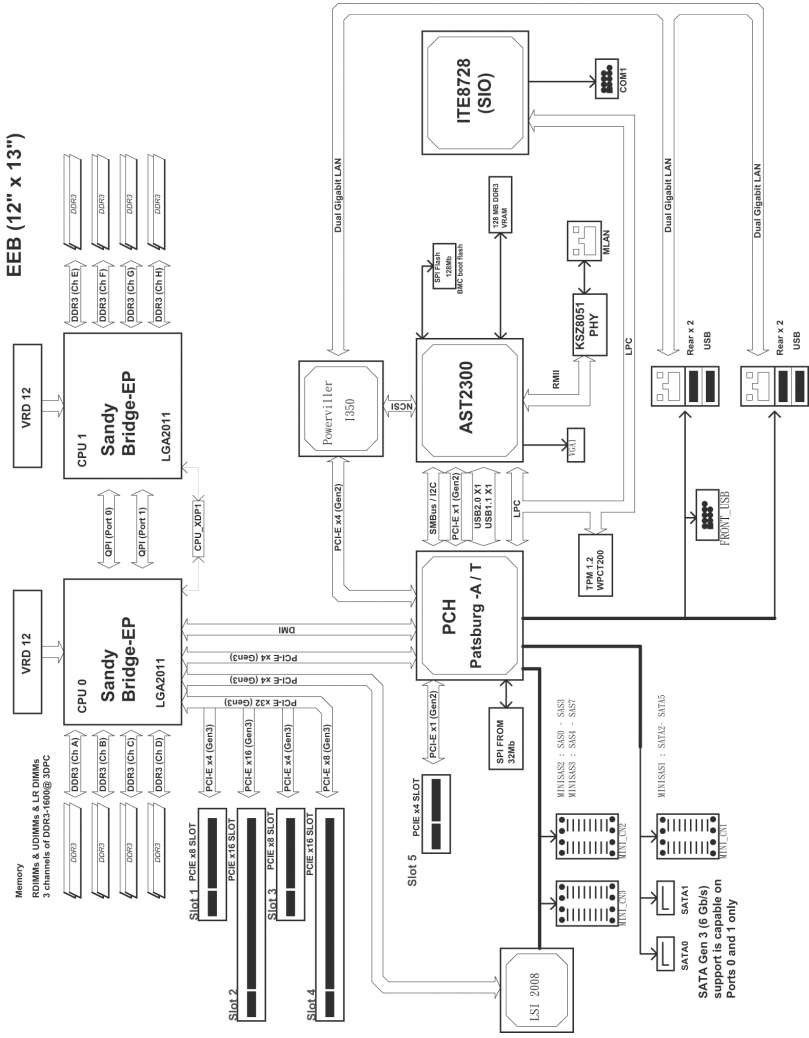









# Chapter 1 Hardware Installation







## 1-1 Installation Precautions

The motherboard contains numerous delicate electronic circuits and components which can become damaged as a result of electrostatic discharge (ESD). Prior to installation, carefully read the user's manual and follow these procedures:

- Prior to installation, do not remove or break motherboard S/N (Serial Number) sticker or warranty sticker provided by your dealer. These stickers are required for warranty validation.
- Always remove the AC power by unplugging the power cord from the power outlet before installing or removing the motherboard or other hardware components.
- When connecting hardware components to the internal connectors on the motherboard, make sure they are connected tightly and securely.
- When handling the motherboard, avoid touching any metal leads or connectors.
- It is best to wear an electrostatic discharge (ESD) wrist strap when handling electronic components such as a motherboard, CPU or memory. If you do not have an ESD wrist strap, keep your hands dry and first touch a metal object to eliminate static electricity.
- Prior to installing the motherboard, please have it on top of an antistatic pad or within an electrostatic shielding container.
- Before unplugging the power supply cable from the motherboard, make sure the power supply has been turned off.
- Before turning on the power, make sure the power supply voltage has been set according to the local voltage standard.
- Before using the product, please verify that all cables and power connectors of your hardware components are connected.
- To prevent damage to the motherboard, do not allow screws to come in contact with the motherboard circuit or its components.
- Make sure there are no leftover screws or metal components placed on the motherboard or within the computer casing.
- Do not place the computer system on an uneven surface.
- Do not place the computer system in a high-temperature environment.
- Turning on the computer power during the installation process can lead to damage to system components as well as physical harm to the user.
- If you are uncertain about any installation steps or have a problem related to the use of the product, please consult a certified computer technician.

## 1-2 Product Specifications

	CPU	<ul style="list-style-type: none"> <li>◆ Support for Intel® Xeon® E5-2600 series processors in the LGA2011 package</li> <li>◆ L3 cache varies with CPU</li> <li>◆ Supports QuickPath Interconnect up to 8GT/s</li> <li>◆ Enhanced Intel SpeedStep Technology (EIST)</li> <li>◆ Support Intel Virtualization Technology (VT)</li> </ul>
	Chipset	<ul style="list-style-type: none"> <li>◆ Intel® C602 (Patsburg) Chipset</li> </ul>
	Memory	<ul style="list-style-type: none"> <li>◆ 16 x 1.5V DDR3 DIMM sockets supporting up to 128GB (UDIMM) and 512GB (RDIMM) of system memory               <ul style="list-style-type: none"> <li>* Due to Windows 32-bit operating system limitation, when more than 4 GB of physical memory is installed, the actual memory size displayed will be less than 4 GB.</li> </ul> </li> <li>◆ 16 x 1.35V DDR3L DIMM sockets supporting up to 128 GB of system memory</li> <li>◆ Four channel memory architecture</li> <li>◆ Support for 800/1066/1333/1600 memory modules</li> <li>◆ Support for ECC RDIMM/ UDIMM memory modules</li> </ul>
	LAN	<ul style="list-style-type: none"> <li>◆ Intel® I350 supports 10/100/1000 Mbps (GA-7PESH1)</li> <li>◆ Intel® X540-AT2 supports dual 10G Base-T ethernet LAN ports (GA-7PESH2)</li> </ul>
	Expansion Slots	<ul style="list-style-type: none"> <li>◆ 1 x PCI Express x16 slot, running at x16 (Gen3/PCIE_2)</li> <li>◆ 1 x PCI Express x16 slot, running at x8 (Gen3/PCIE_4)</li> <li>◆ 2 x PCI Express x8 slot, running at x4 (Gen3/PCIE_1/PCIE_3)</li> <li>◆ 1 x PCI Express x4 slot, running at x1 (Gen2/PCIE_5)</li> </ul>
	Onboard Graphics	<ul style="list-style-type: none"> <li>◆ ASPEED® AST2300 supports 16MB VRAM</li> </ul>
	Storage Interface	<ul style="list-style-type: none"> <li>◆ Intel® C602 controller</li> <li>◆ 2 x SATA 6Gb/s connectors (SATA0/1)</li> <li>◆ 1 x SAS 3Gb/s connector (4 additional ports via the SATA brackets connected to the internal SAS headers)</li> <li>◆ 2 x SAS 6Gb/s connectors (8 additional ports via the SAS brackets connected to the internal SAS headers)</li> <li>◆ Support for Intel RSTe SATA RAID 0, RAID 1</li> </ul>
	USB	<ul style="list-style-type: none"> <li>◆ Up to 6 USB 2.0/1.1 ports (4 on the back panel, 2 additional ports via the USB brackets connected to the internal USB headers/GA-7PESH1)</li> <li>◆ Up to 4 USB 2.0/1.1 ports (2 on the back panel, 2 additional ports via the USB brackets connected to the internal USB headers/GA-7PESH2)</li> </ul>

	Internal Connectors	<ul style="list-style-type: none"> <li>◆ 1 x 24-pin ATX main power connector</li> <li>◆ 2 x 8-pin ATX 12V power connector</li> <li>◆ 2 x Mini SAS connectors (SAS 6Gb/s signal)</li> <li>◆ 1 x Mini SAS connector (SATA 3Gb/s signal)</li> <li>◆ 2 x SATA 6Gb/s connectors</li> <li>◆ 1 x PSM1 header</li> <li>◆ 2 x CPU fan header</li> <li>◆ 2 x System fan header</li> <li>◆ 1 x Front panel header</li> <li>◆ 1 x Back panel header</li> <li>◆ 1 x USB 2.0/1.1 header</li> <li>◆ 1 x TPM header</li> <li>◆ 1 x SKU KEY header</li> <li>◆ 1 x SPGIO header</li> </ul>
	Rear Panel I/O	<ul style="list-style-type: none"> <li>◆ 4 x USB 2.0/1.1 ports (GA-7PESH1)</li> <li>◆ 2 x USB 2.0/1.1 ports (GA-7PESH2)</li> <li>◆ 3 x RJ-45 port</li> <li>◆ 1 x COM port</li> <li>◆ 1 x VGA port</li> <li>◆ 1 x ID Switch button</li> </ul>
	I/O Controller	<ul style="list-style-type: none"> <li>◆ ASPEED® AST2300 BMC chip</li> </ul>
	Hardware Monitor	<ul style="list-style-type: none"> <li>◆ System voltage detection</li> <li>◆ CPU/System temperature detection</li> <li>◆ CPU/System fan speed detection</li> <li>◆ CPU/System fan speed control <ul style="list-style-type: none"> <li>* Whether the CPU/system fan speed control function is supported will depend on the CPU/system cooler you install.</li> </ul> </li> </ul>
	BIOS	<ul style="list-style-type: none"> <li>◆ 1 x 64 Mbit flash</li> <li>◆ AMI BIOS</li> </ul>
	Form Factor	<ul style="list-style-type: none"> <li>◆ EATX Form Factor; 12 inch x 13 inch, 8 layers PCB</li> </ul>

\* GIGABYTE reserves the right to make any changes to the product specifications and product-related information without prior notice.

## 1-3 Installing the CPU and CPU Cooler



Read the following guidelines before you begin to install the CPU:

- Make sure that the motherboard supports the CPU.  
(Go to GIGABYTE's website for the latest CPU support list.)
- Always turn off the computer and unplug the power cord from the power outlet before installing the CPU to prevent hardware damage.
- Locate the pin one of the CPU. The CPU cannot be inserted if oriented incorrectly. (Or you may locate the notches on both sides of the CPU and alignment keys on the CPU socket.)
- Apply an even and thin layer of thermal grease on the surface of the CPU.
- Do not turn on the computer if the CPU cooler is not installed, otherwise overheating and damage of the CPU may occur.
- Set the CPU host frequency in accordance with the CPU specifications. It is not recommended that the system bus frequency be set beyond hardware specifications since it does not meet the standard requirements for the peripherals. If you wish to set the frequency beyond the standard specifications, please do so according to your hardware specifications including the CPU, graphics card, memory, hard drive, etc.

### 1-3-1 Installing the CPU

A. Locate the alignment keys on the motherboard CPU socket and the notches on the CPU.

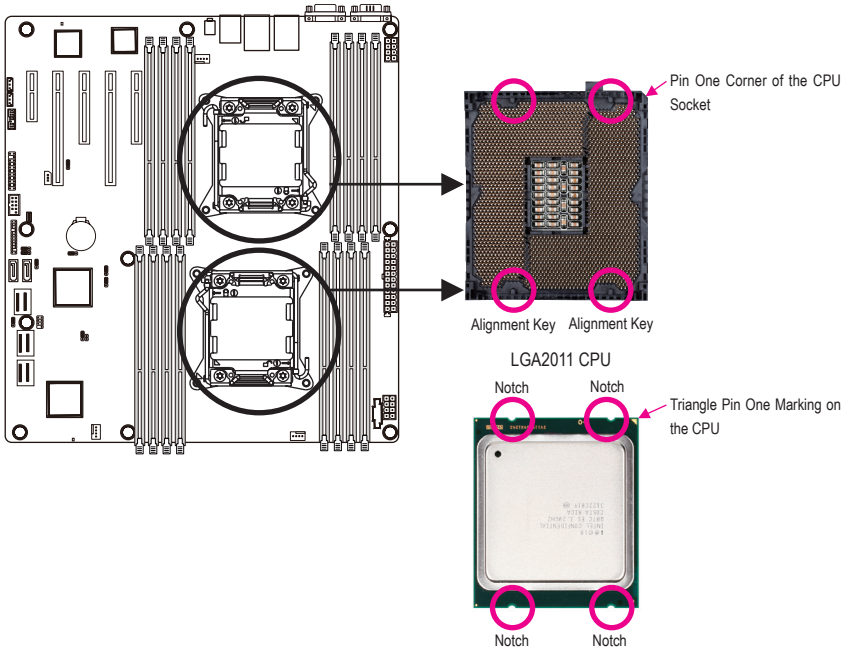

B. Follow the steps below to correctly install the CPU into the motherboard CPU socket.



- Before installing the CPU, make sure to turn off the computer and unplug the power cord from the power outlet to prevent damage to the CPU.
- To protect the socket contacts, do not remove the protective plastic cover unless the CPU is inserted into the CPU socket. Save the cover properly and replace it if the CPU is removed.

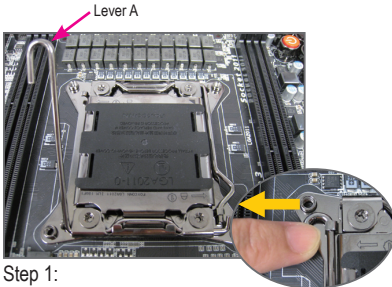

Step 1:

Push the lever closest to the "unlock" marking "☐" (below referred as lever A) down and away from the socket to release it.

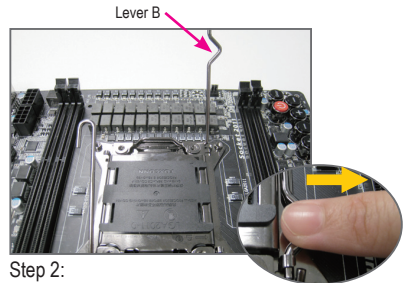

Step 2:

Push the lever closest to the "lock" marking "☒" (below referred as lever B) down and away from the socket. Then lift the lever.



Step 3:

Gently press lever A to allow the load plate to rise. Open the load plate. (Note: DO NOT touch the socket contacts after the load plate is opened.)

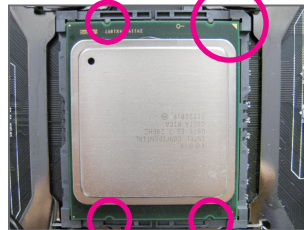

Step 4:

Hold the CPU with your thumb and index fingers. Align the CPU pin one marking (triangle) with the pin one corner of the CPU socket (or align the CPU notches with the socket alignment keys) and carefully insert the CPU into the socket vertically.



Step 5:

Once the CPU is properly inserted, carefully replace the load plate. Then secure lever B under its retention tab. The protective plastic cover may pop off from the load plate during the process of engaging the lever. Remove the cover. Save the cover properly and always replace it when the CPU is not installed.



Step 6:

Finally, secure lever A under its retention tab to complete the installation of the CPU.

## 1-3-2 Installing the CPU Cooler

Refer to the steps below to correctly install the CPU cooler on the motherboard. (Actual installation process may differ depending the CPU cooler to be used. Refer to the user's manual for your CPU cooler.)



### Step 1:

Apply an even and thin layer of thermal grease on the surface of the installed CPU.

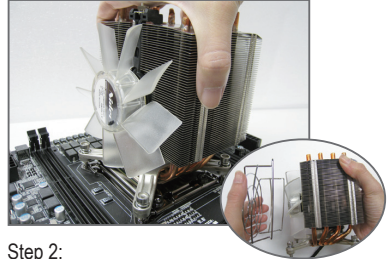

### Step 2:

Place the cooler atop the CPU, aligning the four mounting screws with the mounting holes on the ILM. (If your cooler has a fan grill which may cause interference when you tighten the screws, remove it first and replace it after tightening the screws.)

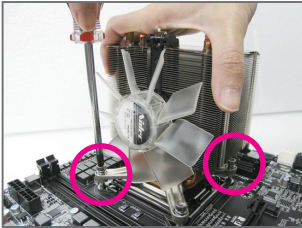

### Step 3:

Use one hand to hold the cooler and the other to tighten the screws in a diagonal sequence with a screw driver. Begin tightening a screw with a few turns and repeat with the screw diagonally opposite the one you just tightened. Then do the same to the other pair. Next, fully tighten the four screws.

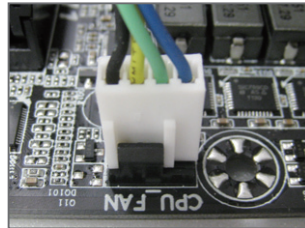

### Step 4:

Finally, attach the power connector of the CPU cooler to the CPU fan header (CPU\_FAN) on the motherboard.



Please pay more attention when removing the CPU cooler because the thermal grease/tape between the CPU cooler and CPU may adhere to the CPU. Inadequately removing the CPU cooler may damage the CPU.

## 1-4 Installing the Memory



Read the following guidelines before you begin to install the memory:

- Make sure that the motherboard supports the memory. It is recommended that memory of the same capacity, brand, speed, and chips be used.  
(Go to GIGABYTE's website for the latest supported memory speeds and memory modules.)
- Always turn off the computer and unplug the power cord from the power outlet before installing the memory to prevent hardware damage.
- Memory modules have a foolproof design. A memory module can be installed in only one direction. If you are unable to insert the memory, switch the direction.

### 1-4-1 Four Channel Memory Configuration

This motherboard provides eight DDR3 memory sockets and supports Four Channel Technology. After the memory is installed, the BIOS will automatically detect the specifications and capacity of the memory. Enabling Four Channel memory mode will be four times of the original memory bandwidth.

The four DDR3 memory sockets are divided into four channels each channel has two memory sockets as following:

- Channel 1: DDR3\_P0\_A0, DDR3\_P0\_A1 (For primary CPU)  
DDR3\_P0\_E0, DDR3\_P0\_E1 (For secondary CPU)
- Channel 2: DDR3\_P0\_B0, DDR3\_P0\_B1 (For primary CPU)  
DDR3\_P0\_F0, DDR3\_P0\_F1 (For secondary CPU)
- Channel 3: DDR3\_P0\_C0, DDR3\_P0\_C1 (For primary CPU)  
DDR3\_P0\_G0, DDR3\_P0\_G1 (For secondary CPU)
- Channel 4: DDR3\_P0\_D0, DDR3\_P0\_D1 (For primary CPU)  
DDR3\_H0\_F0, DDR3\_P0\_H1 (For secondary CPU)

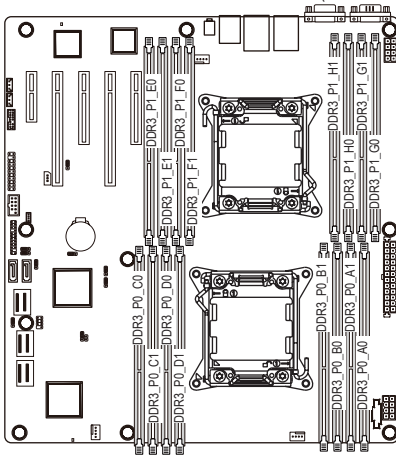

Due to CPU limitations, read the following guidelines before installing the memory in Four Channel mode.

1. Four Channel mode cannot be enabled if only one DDR3 memory module is installed.
2. When enabling Four Channel mode with two or four memory modules, it is recommended that memory of the same capacity, brand, speed, and chips be used for optimum performance.



## 1-4-2 Installing a Memory



Before installing a memory module, make sure to turn off the computer and unplug the power cord from the power outlet to prevent damage to the memory module.

Be sure to install DDR3 DIMMs on this motherboard.

### Installation Step:

Step 1. Insert the DIMM memory module vertically into the DIMM slot, and push it down.

Step 2. Close the plastic clip at both edges of the DIMM slots to lock the DIMM module.

Note: For dual-channel operation, DIMMs must be installed in matched pairs.

Step 3. Reverse the installation steps when you wish to remove the DIMM module.

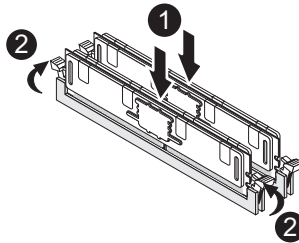

## 1-4-3 DIMM Population Table

R-DIMM	1N or 2N	DIMM1	DIMM0
	1N	Empty	Single-Rank
	1N	Empty	Dual-Rank
	1N	Empty	Quad-Rank
	1N	Single-Rank	Single-Rank
	1N	Single-Rank	Dual-Rank
	1N	Dual-Rank	Dual-Rank
	1N	Single-Rank	Quad-Rank
	1N	Dual-Rank	Quad-Rank
	1N	Quad-Rank	Quad-Rank

U-DIMM	1N or 2N	DIMM1	DIMM0
	1N	Empty	Single-Rank
	1N	Empty	Dual-Rank
	2N	Single-Rank	Single-Rank
	2N	Single-Rank	Dual-Rank
	2N	Dual-Rank	Dual-Rank

# 1-5 Back Panel Connectors

## GA-7PESH1

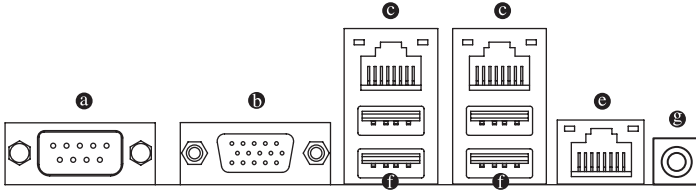

## GA-7PESH2

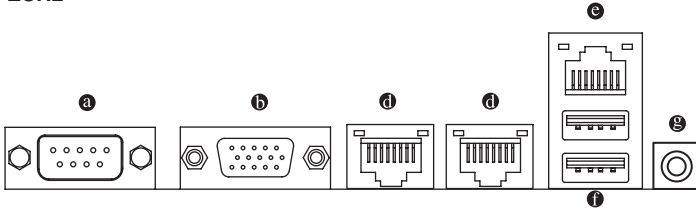

**a Serial Port**

Connects to serial-based mouse or data processing devices.

**b Video Port**

The video in port allows connect to video in, which can also apply to video loop thru function.

**c RJ-45 LAN Port (Gigabit Ethernet LAN Port)**

The Gigabit Ethernet LAN port provides Internet connection at up to 1 Gbps data rate. The following describes the states of the LAN port LEDs.

**d RJ-45 LAN Port (10 Gigabit Ethernet LAN Port)**

The 10 Gigabit Ethernet LAN port provides Internet connection at up to 10 Gbps data rate. The following describes the states of the LAN port LEDs.

**e KVM Server Management 10/100 LAN Port**

The LAN port provides Internet connection with data transfer speeds of 10/100Mbps.

**f USB 2.0/1.1 Port**

The USB port supports the USB 2.0/1.1 specification. Use this port for USB devices such as a USB keyboard/mouse, USB printer, USB flash drive and etc.

**g ID Switch Button**

This button provide the selected unit identification function.

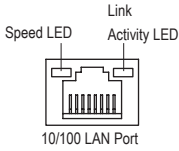

MLAN Speed LED:

State	Description
Green On	100 Mbps data rate
Green Blink	10 Mbps or 100 Mbps data rate
Off	10 Mbps data rate

Link/Activity LED:

State	Description
On	Link between system and network or no access
Blinking	Data transmission or receiving is occurring
Off	No data transmission or receiving is occurring

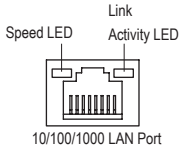

1350 Speed LED:

State	Description
Yellow On	1 Gbps data rate
Yellow Blink	Identify 1 Gbps data rate
Green On	100 Mbps data rate
Green Blink	Identify 100 Mbps data rate
Off	10 Mbps data rate

Link/Activity LED:

State	Description
On	Link between system and network or no access
Blinking	Data transmission or receiving is occurring
Off	No data transmission or receiving is occurring

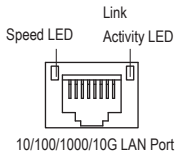

X540 Speed LED:

State	Description
Green On	10 Gbps data rate
Green Blink	Identify 10 Gbps data rate
Yellow On	1 Gbps data rate
Yellow Blink	Identify 1 Gbps data rate
Off	10 Mbps or 100 Mbps data rate

Link/Activity LED:

State	Description
On	Link between system and network or no access
Blinking	Data transmission or receiving is occurring
Off	No data transmission or receiving is occurring



- When removing the cable connected to a back panel connector, first remove the cable from your device and then remove it from the motherboard.
- When removing the cable, pull it straight out from the connector. Do not rock it side to side to prevent an electrical short inside the cable connector.

# 1-6 Internal Connectors

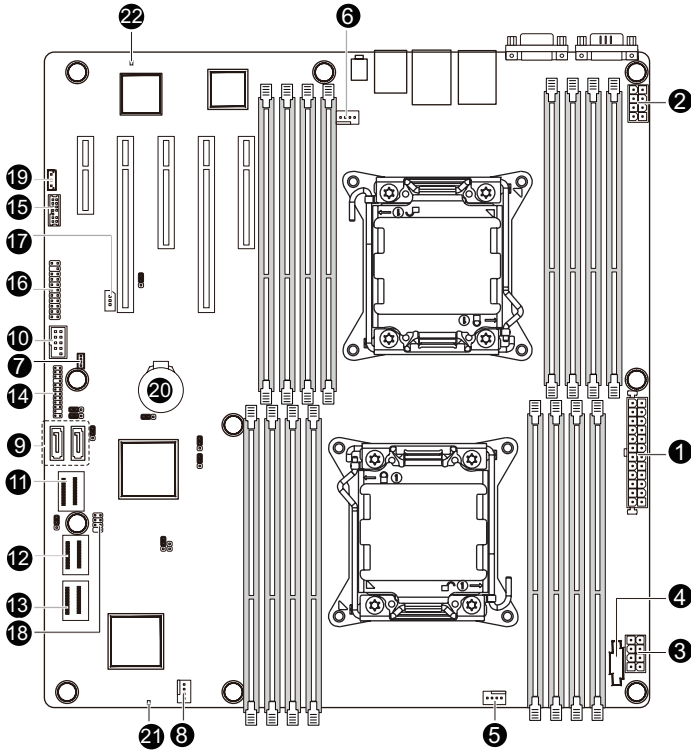

1) ATX1	12) MINII_CN2
2) P12V_AUX2	13) MINII_CN3
3) P12V_AUX1	14) BP_1
4) PWR_DET1	15) TPM_1
5) CPU0_FAN (for primary CPU)	16) F_PANEL1
6) CPU1_FAN (for secondary CPU)	17) IPMB1
7) SYS_FAN1 (System Fan)	18) SATA_SGPIO
8) SYS_FAN2 (System Fan)	19) SKU_KEY1
9) SATA0/1	20) BAT1
10) FRONT_USB	21) LED2
11) MINII_CN1	22) BMC_LED1



Read the following guidelines before connecting external devices:

- First make sure your devices are compliant with the connectors you wish to connect.
- Before installing the devices, be sure to turn off the devices and your computer. Unplug the power cord from the power outlet to prevent damage to the devices.
- After installing the device and before turning on the computer, make sure the device cable has been securely attached to the connector on the motherboard.

### 1/2/3) ATX1/P12V\_AUX2/P12V\_AUX1

#### (2x4 12V Power Connector and 2x12 Main Power Connector)

With the use of the power connector, the power supply can supply enough stable power to all the components on the motherboard. Before connecting the power connector, first make sure the power supply is turned off and all devices are properly installed. The power connector possesses a foolproof design. Connect the power supply cable to the power connector in the correct orientation. The 12V power connector mainly supplies power to the CPU. If the 12V power connector is not connected, the computer will not start.



To meet expansion requirements, it is recommended that a power supply that can withstand high power consumption be used (500W or greater). If a power supply is used that does not provide the required power, the result can lead to an unstable or unbootable system.

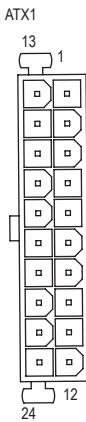
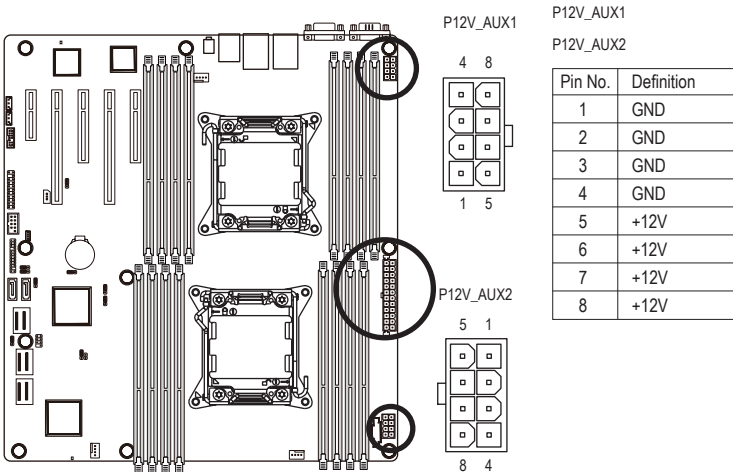

ATX1

Pin No.	Definition	Pin No.	Definition
1	3.3V	13	3.3V
2	3.3V	14	-12V
3	GND	15	GND
4	+5V	16	PS_ON
5	GND	17	GND
6	+5V	18	GND
7	GND	19	GND
8	Power Good	20	-5V
9	5VSB (stand by +5V)	21	+5V
10	+12V	22	+5V
11	+12V	23	+5V
12	3.3V	24	GND

#### 4) PWR\_DET1 (Power management connector)

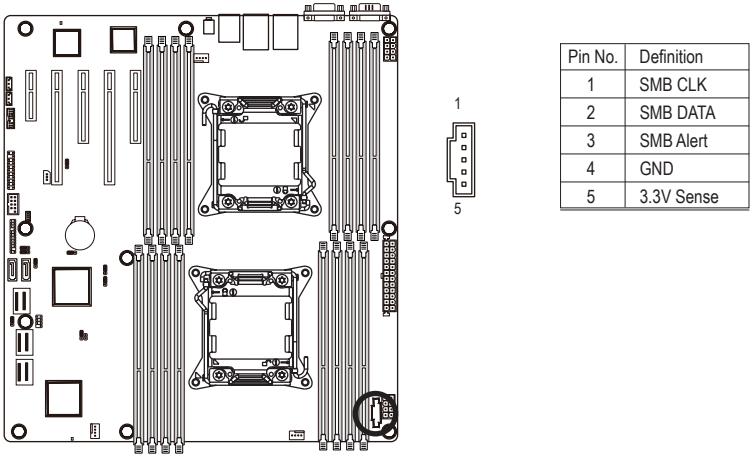

#### 5/6/7/8) CPU\_FAN/CPU1\_FAN/SYS\_FAN1/SYS\_FAN2 (CPU Fan/System Fan Headers)

The motherboard has a 4-pin CPU fan header (CPU\_FAN1/2), a 4-pin (FAN4) system fan headers. Most fan headers possess a foolproof insertion design. When connecting a fan cable, be sure to connect it in the correct orientation (the black connector wire is the ground wire). The motherboard supports CPU fan speed control, which requires the use of a CPU fan with fan speed control design. For optimum heat dissipation, it is recommended that a system fan be installed inside the chassis.

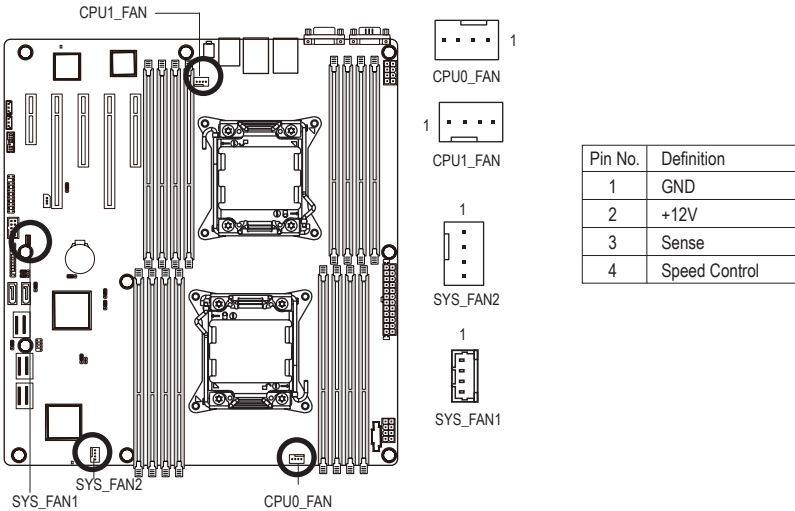

- Be sure to connect fan cables to the fan headers to prevent your CPU and system from overheating. Overheating may result in damage to the CPU or the system may hang.
- These fan headers are not configuration jumper blocks. Do not place a jumper cap on the headers.

### 9) SATA0/SATA1 (SATA 6Gb/s Connectors)

The SATA connectors conform to SATA 6Gb/s standard and are compatible with SATA 3Gb/s and 1.5Gb/s standard. Each SATA connector supports a single SATA device.

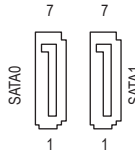
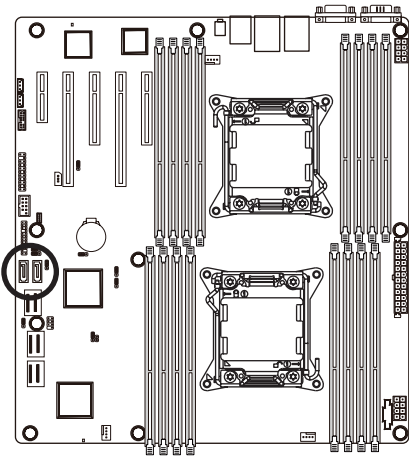

When SATA\_DOM1/2 jumper are set to **Normal Mode**:

Pin No.	Definition
1	GND
2	TXP
3	TXN
4	GND
5	RXN
6	RXP
7	GND

When SATA\_DOM1/2 Jumper are set to **1-2 pin**:

Pin No.	Definition
1	GND
2	TXP
3	TXN
4	GND
5	RXN
6	RXP
7	P5V



- A RAID 0 or RAID 1 configuration requires at least two hard drives. If more than two hard drives are configured, the total number of hard drives must be an even number.
- A RAID 10 configuration requires four hard drives.

(Note) When a RAID configuration is built across the SATA 6Gb/s channels, the system performance of the RAID configuration may vary depends on the devices are connected.

### 10) FRONT\_USB (Front USB Headers)

The headers conform to USB 2.0/1.1 specification. Each USB header can provide two USB ports via an optional USB bracket. For purchasing the optional USB bracket, please contact the local dealer.

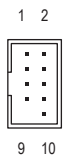
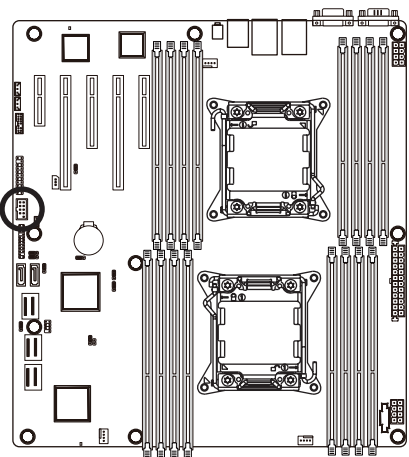

Pin No.	Definition
1	Power (5V)
2	Power (5V)
3	USB DX-
4	USB DY-
5	USB DX+
6	USB DY+
7	GND
8	GND
9	No Pin
10	NC



### 11) MINI\_CN1 (Mini SAS cable connector with SATA 3Gb/s signal)

The SATA connectors conform to SATA 3Gb/s standard and are compatible with SATA 1.5Gb/s standard.

Each SATA connector supports two SATA device.

### 12/13) MINI\_CN2/MINI\_CN3 (Mini SAS cable connectors)

The mini SAS connectors conform to SAS 6Gb/s standard.

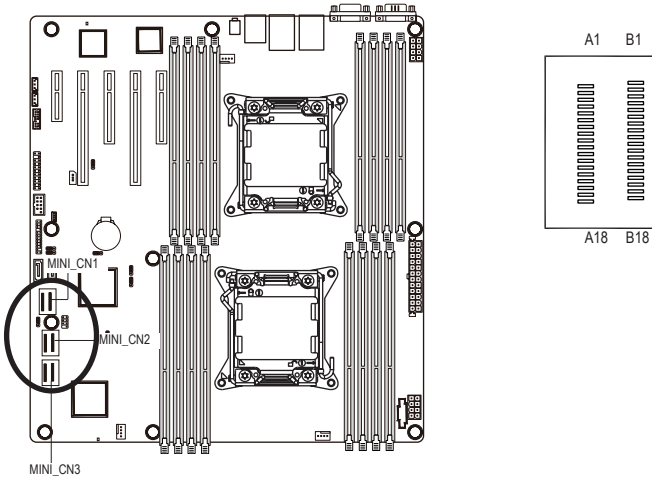

MINI\_CN1

Pin No.	Definition	Pin No.	Definition
A1	GND	B1	GND
A2	RX0+	B2	TX0+
A3	RX0-	B3	TX0-
A4	GND	B4	GND
A5	RX1+	B5	TX1+
A6	RX1-	B6	TX1-
A7	GND	B7	GND
A8	SIB7	B8	SIB0
A9	SIB3	B9	SIB1
A10	SIB4	B10	SIB2
A11	SIB5	B11	SIB6
A12	GND	B12	GND
A13	RX2+	B13	TX2+
A14	RX2-	B14	TX2-
A15	GND	B15	GND
A16	RX3+	B16	TX3+
A17	RX3-	B17	TX3-
A18	GND	A18	GND

MINI\_CN2

MINI\_CN3

Pin No.	Definition	Pin No.	Definition
A1	GND	B1	GND
A2	RX0+	B2	TX0+
A3	RX0-	B3	TX0-
A4	GND	B4	GND
A5	RX1+	B5	TX1+
A6	RX1-	B6	TX1-
A7	GND	B7	GND
A8	SIB7	B8	SIB0
A9	SIB3	B9	SIB1
A10	SIB4	B10	SIB2
A11	SIB5	B11	SIB6
A12	GND	B12	GND
A13	RX2+	B13	TX2+
A14	RX2-	B14	TX2-
A15	GND	B15	GND
A16	RX3+	B16	TX3+
A17	RX3-	B17	TX3-
A18	GND	A18	GND

### 14) BP\_1 (HDD Back Plane Board Header)

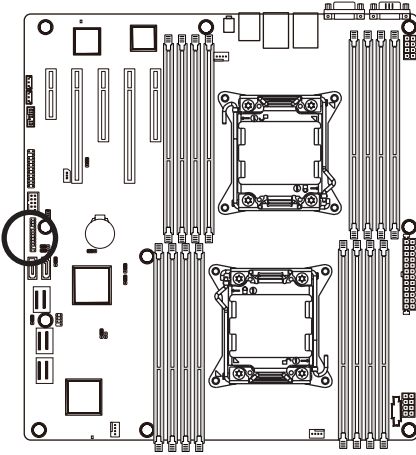

Pin No.	Definition
1	AST2300_SCGLCK
2	FM_THROTTLE_AND_N
3	AST2300_SGLD
4	IQO_FAN_12v_GATE_N
5	AST2300_SGDOUT
6	GND
7	KEY
8	RresetL_BRB
9	GND
10	BP_ALED_N
11	BP_LED_G_N
12	GND
13	AST2300_SGDIN
14	ASSESS#_LED_BPB
15	GND
16	SMB_BPB1_DATA
17	GND
18	SMB_BPB1_CLK
19	P_3V3_AUX
20	BP_HDD_TYPE
21	P_3V3_AUX
22	FAN_TYPE
23	GND
24	KEY
25	BP_PRESENSE
26	GND

### 15) TPM\_1 (TPM Module Connector)

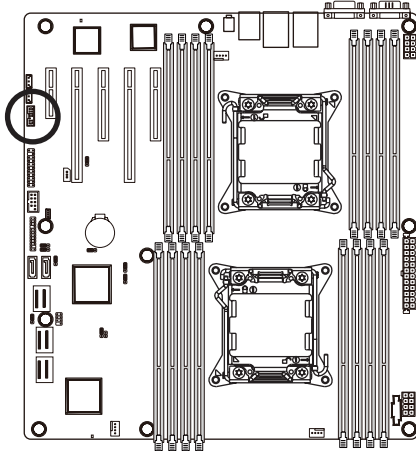

Pin No.	Definition
1	CLK_33M_TPM
2	P_3V3_AUX
3	LPC_RST_DEBUG
4	P3V3
5	LPC_LAD0
6	IRQ_SERIAL
7	LPC_LAD1
8	TPM_DET_N
9	LPC_LAD2
10	NC
11	LPC_LAD3
12	GND
13	LPC_FRAME_N
14	GND

## 16) F\_Panel1 (Front Panel Header)

Connect the power switch, reset switch, speaker, chassis intrusion switch/sensor and system status indicator on the chassis to this header according to the pin assignments below. Note the positive and negative pins before connecting the cables.

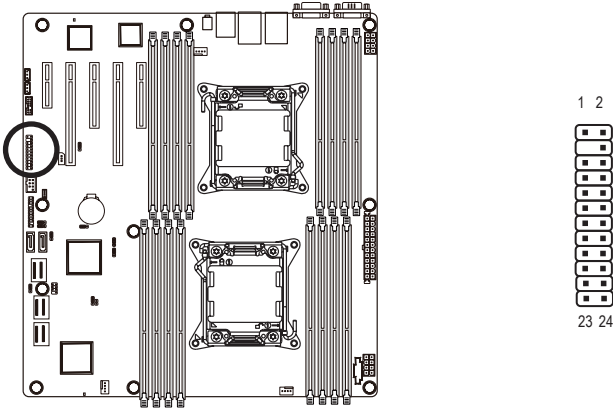

Pin No.	Signal Name	Definition
1	PWR_LED+	Power LED Anode
2	5VSB	Front Panel Power
3	KEY	Key
4	ID_LED+	System ID LED Anode
5	PWR_LED-	Power LED Cathode
6	ID_LED-	System ID LED Cathode
7	HDD_LED+	HDD Activity LED Anode
8	SYS_STATUS+	System Fault LED Anode
9	HDD_LED-	HDD Activity LED Cathode
10	SYS_STATUS-	System Fault LED Cathode
11	PWR_BTN	Power Switch
12	LAN1_LED+	NIC#1 Activity LED Anode
13	PWR_BTN (GND)	Power Switch (GND)
14	LAN1_LED-	NIC#1 Activity LED Cathode
15	RST_BTN	Reset Switch
16	SDA	SMBus SDA
17	RST_BTN (GND)	Reset Switch (GND)
18	SCL	SMBus SCL
19	ID_BTN	System ID Switch
20	CASE_OPEN	Chassis Intrusion
21	ID_BTN (GND)	System ID Switch (GND)
22	LAN2_LED+	NIC#2 Activity LED Anode
23	NMI_BTN	NMI to CPU Switch
24	LAN2_LED-	NIC#2 Activity LED Cathode



The front panel design may differ by chassis. A front panel module mainly consists of power switch, reset switch, power LED, hard drive activity LED, speaker and etc. When connecting your chassis front panel module to this header, make sure the wire assignments and the pin assignments are matched correctly.

### 17) IPMB1 (IPMB connector)

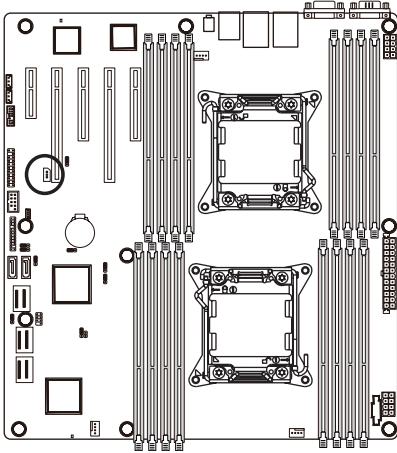

Pin No.	Definition
1	SCL
2	GND
3	SDA

### 18) SATA\_SGPIO (SATA SGPIO Header)

SGPIO is stands for Serial General Purpose Input/Output which is a 4-signal (or 4-wire) bus used between a Host Bus Adapter (HBA) and a backplane. Out of the 4 signals, 3 are driven by the HBA and 1 is driven by the backplane. Typically, the HBA is a storage controller located inside a server, desktop, rack or workstation computer that interfaces with Hard disk drives (HDDs) to store and retrieve data.

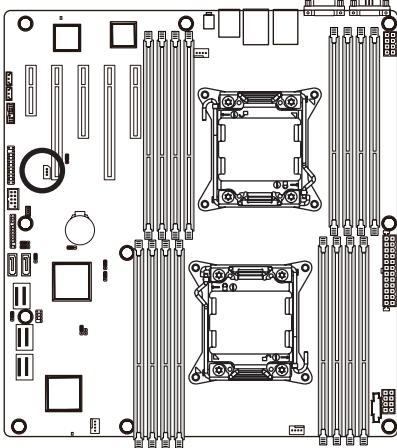

Pin No.	Definition
1	SGPIO_SATA_DATAIN
2	No Pin
3	SGPIO_SATA_DATAOUT
4	GND
5	GND
6	SGPIO_SATA_LOAD
7	NC
8	SGPIO_SATA_CLOCK

## 19) SKU\_KEY1 (Patsburg Upgrade ROM Header)

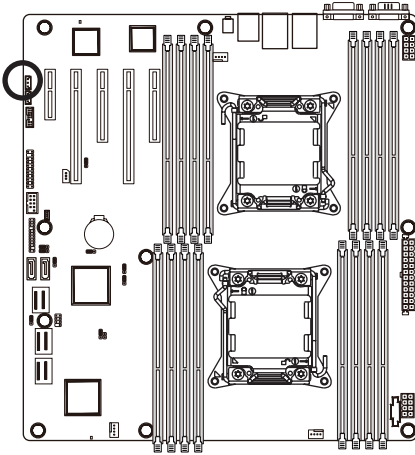

Pin No.	Definition
1	GND
2	FM_PBG_DYN_SKU_KEY
3	GND

## 20) BAT1 (Battery)

The battery provides power to keep the values (such as BIOS configurations, date, and time information) in the CMOS when the computer is turned off. Replace the battery when the battery voltage drops to a low level, or the CMOS values may not be accurate or may be lost.

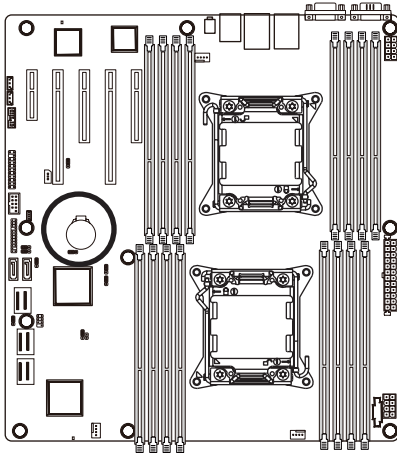

You may clear the CMOS values by removing the battery.

1. Turn off your computer and unplug the power cord.
2. Gently remove the battery from the battery holder and wait for one minute. (Or use a metal object like a screwdriver to touch the positive and negative terminals of the battery holder, making them short for 5 seconds.)
3. Replace the battery.
4. Plug in the power cord and restart your computer.



- Always turn off your computer and unplug the power cord before replacing the battery.
- Replace the battery with an equivalent one. Danger of explosion if the battery is replaced with an incorrect model.
- Contact the place of purchase or local dealer if you are not able to replace the battery by yourself or uncertain about the battery model.
- When installing the battery, note the orientation of the positive side (+) and the negative side (-) of the battery (the positive side should face up).
- Used batteries must be handled in accordance with local environmental regulations.

## 21) LED2 (LSI Firmware Readiness LED)

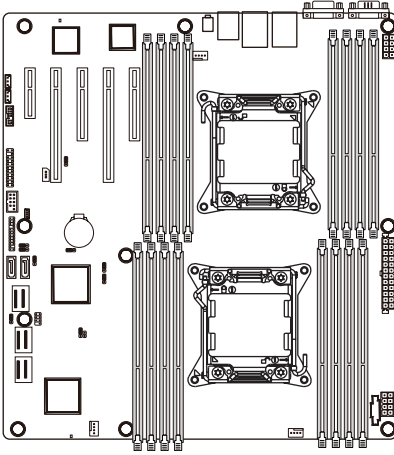

LED2 Link/Activity:

State	Description
Blinking	LSI firmware is ready
Off	LSI firmware is not ready

## 22) BMC\_LED1 (BMC Firmware Readiness LED)

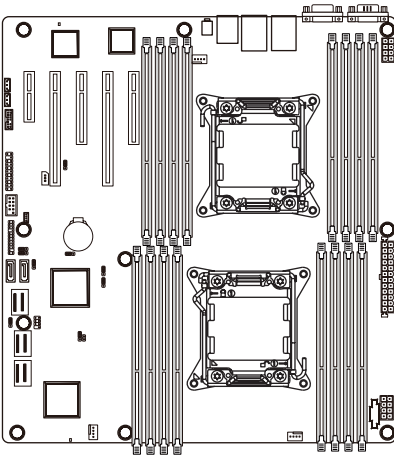

State	Description
On	BMC firmware is initial
Blinking	BMC firmware is ready
Off	System is powered off

# 1-7 Jumper Setting

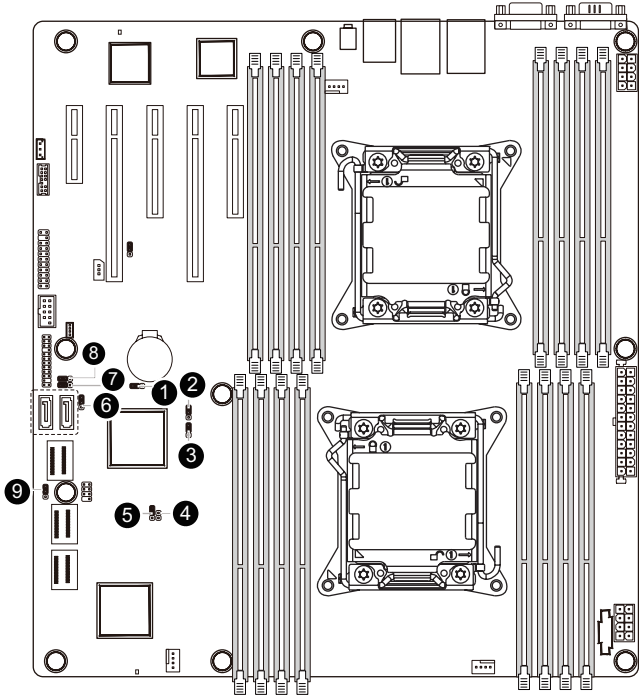



1) CLR_CMOS1	6) BIOS_RCVR1
2) BIOS_WP1	7) SATA_DOM0
3) SSB_ME1	8) SATA_DOM1
4) JP1	9) FLASH_DP1
5) PASSWORD1	

## 1) CLR\_CMOS1 (Clearing CMOS Jumper)

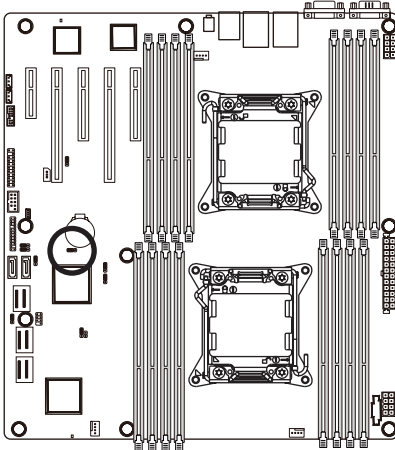
Use this jumper to clear the CMOS values (e.g. date information and BIOS configurations) and reset the CMOS values to factory defaults. To clear the CMOS values, place a jumper cap on the two pins to temporarily short the two pins or use a metal object like a screwdriver to touch the two pins for a few seconds.



1  1-2 Close: Normal operation (Default setting)

1  2-3 Close: Clear CMOS data.



- Always turn off your computer and unplug the power cord from the power outlet before clearing the CMOS values.
- After clearing the CMOS values and before turning on your computer, be sure to remove the jumper cap from the jumper. Failure to do so may cause damage to the motherboard.
- After system restart, go to BIOS Setup Exit menu and load factory defaults (select **Load Default Values**) or manually configure the BIOS settings (refer to Chapter 2, "BIOS Setup," for BIOS configurations).

## 2) BIOS\_WP1 (BIOS Write Protect Jumper)

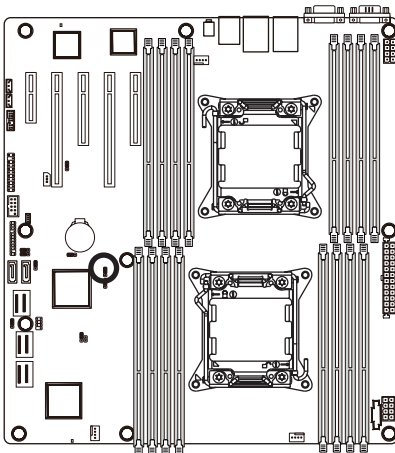

1  1-2 Close: Normal operation. (Default setting)

1  2-3 Close: Enable BIOS write protect function.



### 3) SSB\_ME1 (ME enable/disable Jumper)

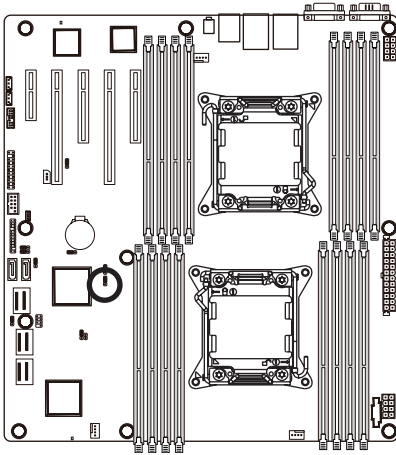

SSB\_ME1

1



1-2 Close: Normal operation. (Default setting)

1



2-3 Close: Disable ME function.

### 4) JP5 (Case Open Intrusion Jumper)

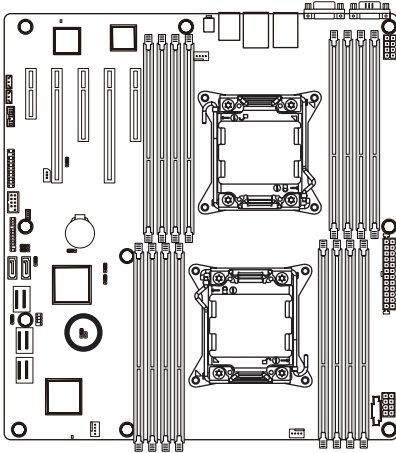



Open: Enable chassis intrusion alert.



Close: Normal operation. (Default setting)

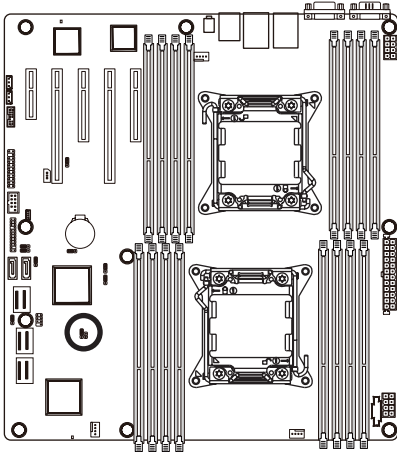

### 5) PASSWORD1 (Skip Supervisor Password Jumper)

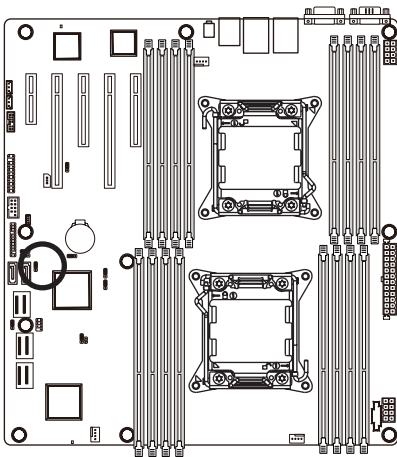

- 1  
 1-2 Close: Normal operation. (Default setting)
- 1  
 2-3 Close: Skip supervisor password.

### 6) BIOS\_RVCR1 (BIOS Recovery Jumper)





- 1  
 1-2 Close: Normal operation. (Default setting)
- 1  
 2-3 Close: BIOS recovery mode.

### 7/8) SATA\_DOM0/1 (SATA DOM Jumper)



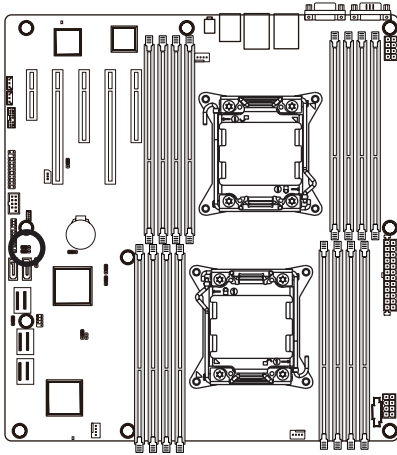

**CAUTION!** If a SATA type hard drive is connected to the motherboard, please ensure the jumper is closed and set to **2-3 pins** (Normal mode), in order to reduce any risk of hard disk damage.

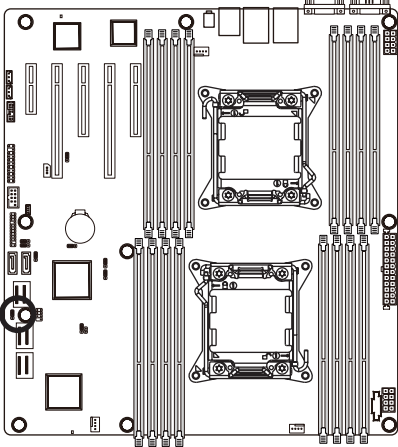

- 1  1-2 Close: Enable SATA0/SATA1 port DOM support.
- 1  2-3 Close: Normal mode. (Default setting)

### 9) FLASH\_DP1 (Flash Descriptor Security Jumper)



- 1  1-2 Close: Flash Descriptor Security Overridden
- 1  2-3 Close: Flash Descriptor Security in effect. (Default setting)

## Chapter 2 BIOS Setup

BIOS (Basic Input and Output System) records hardware parameters of the system in the EFI on the motherboard. Its major functions include conducting the Power-On Self-Test (POST) during system startup, saving system parameters and loading operating system, etc. BIOS includes a BIOS Setup program that allows the user to modify basic system configuration settings or to activate certain system features. When the power is turned off, the battery on the motherboard supplies the necessary power to the CMOS to keep the configuration values in the CMOS.

To access the BIOS Setup program, press the <F2> key during the POST when the power is turned on.



- BIOS flashing is potentially risky, if you do not encounter problems of using the current BIOS version, it is recommended that you don't flash the BIOS. To flash the BIOS, do it with caution. Inadequate BIOS flashing may result in system malfunction.
- It is recommended that you not alter the default settings (unless you need to) to prevent system instability or other unexpected results. Inadequately altering the settings may result in system's failure to boot. If this occurs, try to clear the CMOS values and reset the board to default values. (Refer to the "Restore Defaults" section in this chapter or introductions of the battery/clearing CMOS jumper in Chapter 1 for how to clear the CMOS values.)

### BIOS Setup Program Function Keys

<<-><->>	Move the selection bar to select the screen
<↑><↓>	Move the selection bar to select an item
<Enter>	Execute command or enter the submenu
<+>	Increase the numeric value or make changes
<->	Decrease the numeric value or make changes
<Esc>	Main Menu: Exit the BIOS Setup program Submenus: Exit current submenu
<F1>	Show descriptions of general help
<F3>	Restore the previous BIOS settings for the current submenus
<F9>	Load the Optimized BIOS default settings for the current submenus
<F10>	Save all the changes and exit the BIOS Setup program

■ **Main**

This setup page includes all the items in standard compatible BIOS.

■ **Advanced**

This setup page includes all the items of AMI BIOS special enhanced features.

(ex: Auto detect fan and temperature status, automatically configure hard disk parameters.)

■ **Chipset**

This setup page includes all the submenu options for configuring the function of North Bridge and South Bridge.

(ex: Auto detect fan and temperature status, automatically configure hard disk parameters.)

■ **Security**

Change, set, or disable supervisor and user password. Configuration supervisor password allows you to restrict access to the system and BIOS Setup.

A supervisor password allows you to make changes in BIOS Setup.

A user password only allows you to view the BIOS settings but not to make changes.

■ **Server Management**

Server additional features enabled/disabled setup menus.

■ **Boot**

This setup page provides items for configuration of boot sequence.

■ **Exit**

Save all the changes made in the BIOS Setup program to the CMOS and exit BIOS Setup. (Pressing <F10> can also carry out this task.)

Abandon all changes and the previous settings remain in effect. Pressing <Y> to the confirmation message will exit BIOS Setup. (Pressing <Esc> can also carry out this task.)

## 2-1 The Main Menu

Once you enter the BIOS Setup program, the Main Menu (as shown below) appears on the screen. Use arrow keys to move among the items and press <Enter> to accept or enter other sub-menu.

### Main Menu Help

The on-screen description of a highlighted setup option is displayed on the bottom line of the Main Menu.

### Submenu Help

While in a submenu, press <F1> to display a help screen (General Help) of function keys available for the menu. Press <Esc> to exit the help screen. Help for each item is in the Item Help block on the right side of the submenu.



- When the system is not stable as usual, select the **Load Default Values** item to set your system to its defaults.
- The BIOS Setup menus described in this chapter are for reference only and may differ by BIOS version.

Bios Setup Utility		
Main   Advanced   Chipset   Security   Server Mgmt   Boot   Save & Exit		
BIOS Information		Set the Date. Use Tab to switch between Date elements.
Project Version	T05a	
Build Date and Time	03/18/2013 12:04:13	
BMC Information		
BMC Firmware Version	01.27	
SDR Revision	00.19	
FRU Version	00.02	
Processor Information		
CPU 0	Intel(R) Xeon(R) CPU E5-2650	
CPU 1	Intel(R) Xeon(R) CPU E5-2650	
Max CPU Speed	2000 MHZ	
CPU Signature	206d7	
Processor Cores	8 x 2	
Microcode Patch	70d	
Memory Information		
Total Memory	4096 MB (DDR3)	
Current Memory Speed	1333 MHZ	
System Date		
System Time	[Mon 03/18/2013 [12:47:52]	
++: Select Screen ↑↓: Select Item Enter: Select +/-: Change Opt. F1: General Help F3: Previous Values F9: Optimized Defaults F10: Save & Exit ESC: Exit		
Version 2.15.1236. Copyright (C) 2012 GIGABYTE, Inc.		

☞ **BIOS Information**

☞ **Project Version**

Display version number of the project.

☞ **BMC Information**

☞ **BMC Firmware Version**

Display version number of the Firmware setup utility.

☞ **SDR Reversion**

Display the SDR reversion information.

☞ **FRU Reversion**

Display the FRU reversion information.

☞ **Processor Information**

☞ **CPU Type/ Max CPU Speed/ CPU Signature / Processor Cores / Microcode Patch**

Displays the technical specifications for the installed processor.

☞ **Memory Information**

☞ **Total Memory / Current Memory Speed**

Displays the technical specifications for the installed memory.

☞ **System Date**

Set the date following the weekday-month-day- year format.

☞ **System Time**

Set the system time following the hour-minute- second format.

## 2-2 Advanced Menu

The Advanced menu display submenu options for configuring the function of various hardware components. Select a submenu item, then press Enter to access the related submenu screen.

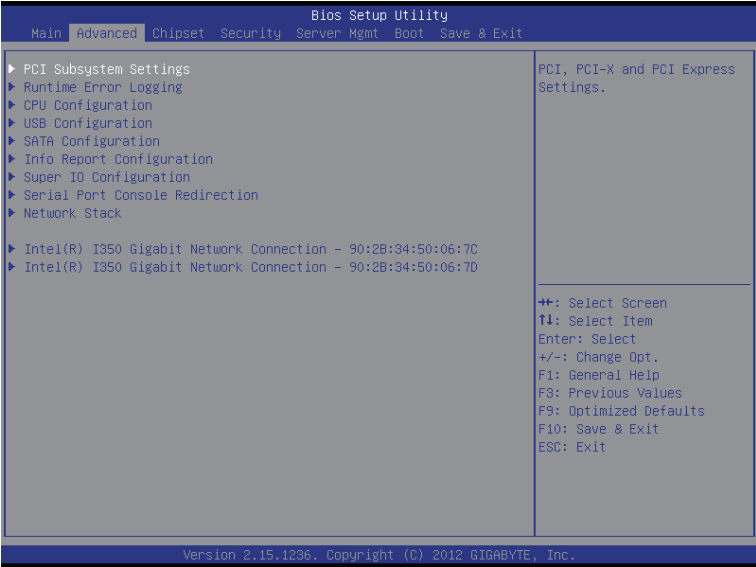



## 2-2-1 PCI Subsystem Settings

Bios Setup Utility

Advanced

PCI Express Slot #1 I/O ROM	[Enabled]	▲ Enable/Disable PCI-Express Slot #1 I/O ROM.
PCI Express Slot #2 I/O ROM	[Enabled]	
PCI Express Slot #3 I/O ROM	[Enabled]	
PCI Express Slot #4 I/O ROM	[Enabled]	
PCI Express Slot #5 I/O ROM	[Enabled]	
LSI Onboard Oprom	[Disabled]	
Onboard LAN1 Controller	[Enabled]	
Onboard LAN2 Controller	[Enabled]	
Onboard LAN I/O ROM Option	[PXE]	
Onboard LAN1 I/O ROM	[Enabled]	
Onboard LAN2 I/O ROM	[Enabled]	++: Select Screen ↑↓: Select Item Enter: Select +/-: Change Opt. F1: General Help F3: Previous Values F9: Optimized Defaults F10: Save & Exit ESC: Exit
PCI 64bit Resources Handling		
Above 4G Decoding	[Disabled]	
PCI Common Settings		
PCI Latency Timer	[32 PCI Bus Clocks]	
VGA Palette Snoop	[Disabled]	
PERR# Generation	[Disabled]	
SERR# Generation	[Disabled]	

Version 2.15.1236, Copyright (C) 2012 GIGABYTE, Inc.

Bios Setup Utility

Advanced

PCI Express Slot #3 I/O ROM	[Enabled]	▲ Change PCI Express Devices Settings.
PCI Express Slot #4 I/O ROM	[Enabled]	
PCI Express Slot #5 I/O ROM	[Enabled]	
LSI Onboard Oprom	[Disabled]	
Onboard LAN1 Controller	[Enabled]	
Onboard LAN2 Controller	[Enabled]	
Onboard LAN I/O ROM Option	[PXE]	
Onboard LAN1 I/O ROM	[Enabled]	
Onboard LAN2 I/O ROM	[Enabled]	
PCI 64bit Resources Handling		
Above 4G Decoding	[Disabled]	
PCI Common Settings		
PCI Latency Timer	[32 PCI Bus Clocks]	
VGA Palette Snoop	[Disabled]	
PERR# Generation	[Disabled]	
SERR# Generation	[Disabled]	
▶ PCI Express Settings		++: Select Screen ↑↓: Select Item Enter: Select +/-: Change Opt. F1: General Help F3: Previous Values F9: Optimized Defaults F10: Save & Exit ESC: Exit

Version 2.15.1236, Copyright (C) 2012 GIGABYTE, Inc.

☞ **PCI Express Slot 1/2/3/4/5 I/O ROM**

When enabled, This setting will initialize the device expansion ROM for the related PCI-E slot.

Options available: Enabled/Disabled. Default setting is **Enabled**.

☞ **Onboard LSI Oprom**

Enable/Disable onboard LSI option ROM.

Options available: Enabled/Disabled. Default setting is **Disabled**.

☞ **Onboard LAN1/2 Controller**

Enable/Disable Onboard LAN controller .

Options available: Enabled/Disabled. Default setting is **Enabled**.

☞ **Onboard LAN1/2 I/O ROM**

Enable/Disable onboard LAN devices and initialize device expansion ROM.

Options available: Enabled/Disabled. Default setting is **Disabled**.

☞ **PCI 64bit Resources Handling**

☞ **Above 4G Decoding**

Enable/Disable Above 4G Decoding.

Options available: Enabled/Disabled. Default setting is **Disabled**.

☞ **PCI Common Settings**

☞ **PCI Latency Timer**

Configure PCI Latency Timer.

Options available: 32 PCI Bus Clocks/64 PCI Bus Clocks/96 PCI Bus Clocks/128 PCI Bus Clocks/160 PCI Bus Clocks/192 PCI Bus Clocks/224 PCI Bus Clocks/248 PCI Bus Clocks.

Default setting is **32 PCI Bus Clocks**.

☞ **VGA Platte Snoop**

Enable/Disable VGA Palette Tegisters Snooping.

Options available: Enabled/Disabled. Default setting is **Disabled**.

☞ **PERR Generation**

When this item is set to enabled, PCI bus parity error (PERR) is generated and is routed to NMI.

Options available: Enabled/Disabled. Default setting is **Disabled**.

☞ **SERR Generation**

When this item is set to enabled, PCI bus system error (SERR) is generated and is routed to NMI.

Options available: Enabled/Disabled. Default setting is **Disabled**.

## 2-2-1-1 PCI Express Settings

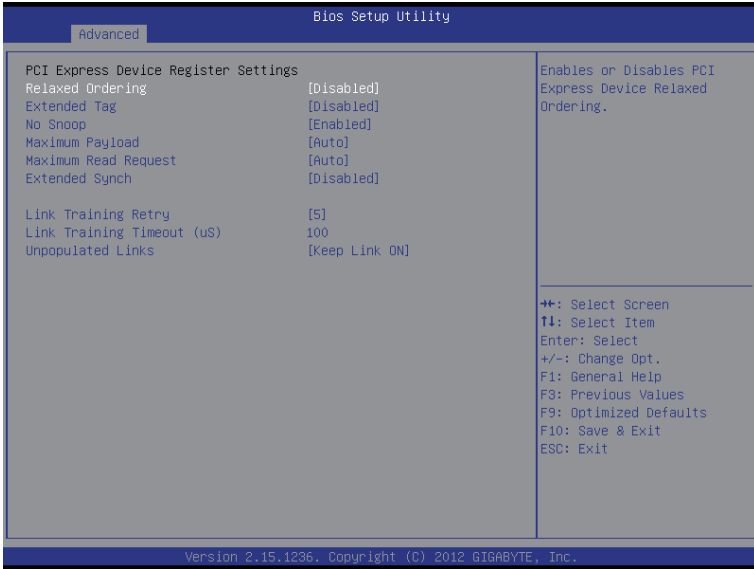

### ☞ PCI Express Device Register Settings

#### ☞ Relaxed Ordering

Enable/Disable PCI Express Device Relaxed Ordering feature.  
Options available: Enabled/Disabled. Default setting is **Disabled**.

#### ☞ Extended Tag

When this feature is enabled, the system will allow device to use 8-bit Tag field as a requester.  
Options available: Enabled/Disabled. Default setting is **Disabled**.

#### ☞ No Snoop

Enable/Disable PCI Express Device No Snoop option.  
Options available: Enabled/Disabled. Default setting is **Enabled**.

#### ☞ Maximum Payload

Set maximum payload for PCI Express Device or allow system BIOS to select the value.  
Options available: Auto/128 Bytes/256 Bytes/512 Bytes/1024 Bytes/2048 Bytes/4096 Bytes.  
Default setting is **Auto**.

#### ☞ Maximum Read Request

Set maximum Read Request size for PCI Express Device or allow system BIOS to select the value.  
Options available: Auto/128 Bytes/256 Bytes/512 Bytes/1024 Bytes/2048 Bytes/4096 Bytes.  
Default setting is **Auto**.

#### ☞ Extended Synch

When this feature is enabled, the system will allow generation of Extended Synchronization patterns.  
Options available: Enabled/Disabled. Default setting is **Enabled**.

### ☞ **Link Training Retry**

Define the number of Retry Attempts software will take to retrain the link if previous training attempt was unsuccessful. Press <+> / <-> keys to increase or decrease the desired values.

### ☞ **Link Training Timeout (us)**

Define the number of Microseconds software will wait before polling 'Link Training' bit in Link Status register. Press <+> / <-> keys to increase or decrease the desired values. Value rang is from 10 to 10000 us.

### ☞ **Unpopulated Links**

When this item is set to 'Disable Link', the system will operate power save feature for those unpopulated PCI Express links.

Options available: Keep Link ON/ Disable. Default setting is **Keep Link ON**.

## 2-2-2 Runtime Error Logging



### ☞ Runtime Error Logging

Enable/Disable Runtime error logging support.

Options available: Enabled/Disabled. Default setting is **Disabled**.

## 2-2-3 CPU Configuration

Bios Setup Utility

Advanced

CPU Configuration		Socket specific CPU Information
<ul style="list-style-type: none"> <li>▶ Socket 0 CPU Information</li> <li>▶ Socket 1 CPU Information</li> </ul>		
CPU Speed	2000 MHz	
64-bit	Supported	
Hyper-threading	[Enabled]	
Active Processor Cores	[All]	
Limit CPUID Maximum	[Disabled]	
Execute Disable Bit	[Enabled]	
Hardware Prefetcher	[Enabled]	
Adjacent Cache Line Prefetch	[Enabled]	
DCU Streamer Prefetcher	[Enabled]	
DCU IP Prefetcher	[Enabled]	
Intel Virtualization Technology	[Enabled]	
▶ CPU Power Management Configuration		

++: Select Screen  
 ↑↓: Select Item  
 Enter: Select  
 +/-: Change Opt.  
 F1: General Help  
 F3: Previous Values  
 F9: Optimized Defaults  
 F10: Save & Exit  
 ESC: Exit

Version 2.15.1236, Copyright (C) 2012 GIGABYTE, Inc.

Bios Setup Utility

Advanced

Socket 1 CPU Information		
Intel(R) Xeon(R) CPU E5-2650 0 @ 2.00GHz		
CPU Signature	206d7	
Microcode Patch	70d	
Max CPU Speed	2000 MHz	
Min CPU Speed	1200 MHz	
Processor Cores	8	
Intel HT Technology	Supported	
Intel VT-x Technology	Supported	
L1 Data Cache	32 kB x 8	
L1 Code Cache	32 kB x 8	
L2 Cache	256 kB x 8	
L3 Cache	20480 kB	

++: Select Screen  
 ↑↓: Select Item  
 Enter: Select  
 +/-: Change Opt.  
 F1: General Help  
 F3: Previous Values  
 F9: Optimized Defaults  
 F10: Save & Exit  
 ESC: Exit

Version 2.15.1236, Copyright (C) 2012 GIGABYTE, Inc.

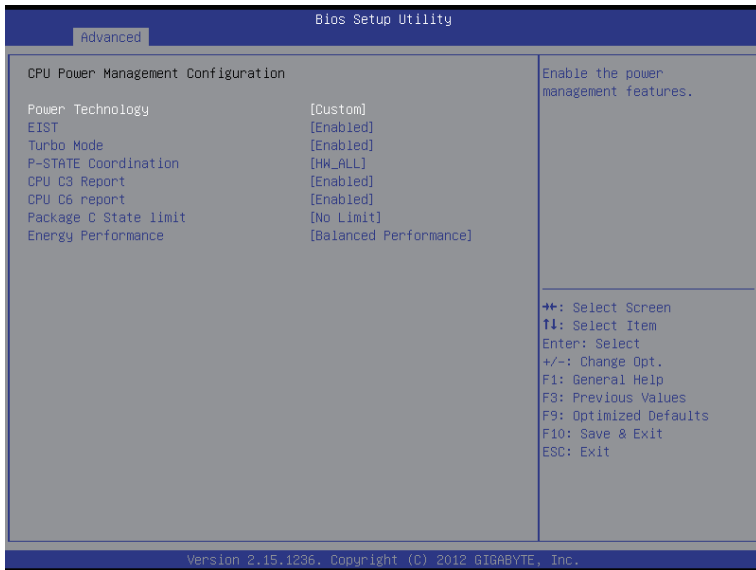

## ☞ CPU Information

### ☞ Socket 0/1 CPU Information

### ☞ CPU Type/ Signature / Microcode Patch / Max CPU Speed / Min CPU Speed / Processor Cores / Intel HT Technology / Intel VT-x Technology

Displays the technical specifications for the installed processor.

### ☞ Intel HT Technology / Intel VT-x Technology

Displays the support information for the installed processor.

## ☞ Cache Information

### ☞ L1 Data Cache / L1 Code Cache / L2 Cache / L3 Cache

Displays the technical specifications for the installed processor.

### ☞ CPU Speed / 64-bit

Displays the technical specifications for the installed processor.

## ☞ Hyper Threading

The Intel Hyper Threading Technology allows a single processor to execute two or more separate threads concurrently. When hyper-threading is enabled, multi-threaded software applications can execute their threads, thereby improving performance.

Options available: Enabled/Disabled. Default setting is **Enabled**.

## ☞ Active Processor Cores <sup>(Note)</sup>

Allows you to determine whether to enable all CPU cores.

Options available: All/1/2/3. Default setting is **All**.

(Note) This item is present only if you install a CPU that supports this feature. For more information about Intel CPUs' unique features, please visit Intel's website.

### ☞ **Limit CPUID Maximum**

When enabled, the processor will limit the maximum CPUID input values to 03h when queried, even if the processor supports a higher CPUID input value.

When disabled, the processor will return the actual maximum CPUID input value of the processor when queried.

Options available: Enabled/Disabled. Default setting is **Disabled**.

### ☞ **Execute Disable Bit**

When enabled, the processor prevents the execution of code in data-only memory pages. This provides some protection against buffer overflow attacks.

When disabled, the processor will not restrict code execution in any memory area. This makes the processor more vulnerable to buffer overflow attacks.

Options available: Enabled/Disabled. Default setting is **Enabled**.

### ☞ **Hardware Prefetcher**

Select whether to enable the speculative prefetch unit of the processor.

Options available: Enabled/Disabled. Default setting is **Enabled**.

### ☞ **Adjacent Cache Line Prefetch**

When enabled, cache lines are fetched in pairs. When disabled, only the required cache line is fetched.

Options available: Enabled/Disabled. Default setting is **Enabled**.

### ☞ **DCU Streamer Prefetch**

Enable prefetch of next L1 Data line based upon multiple loads in same cache line.

Options available: Enabled/Disabled. Default setting is **Enabled**.

### ☞ **DCU IP Prefetch**

Enable prefetch of next L1 Data line based upon sequential load history.

Options available: Enabled/Disabled. Default setting is **Enabled**.

### ☞ **Intel Virtualization Technology**

Select whether to enable the Intel Virtualization Technology function. VT allows a single platform to run multiple operating systems in independent partitions.

Options available: Enabled/Disabled. Default setting is **Enabled**.



## 2-2-3-1 CPU Power Management Configuration

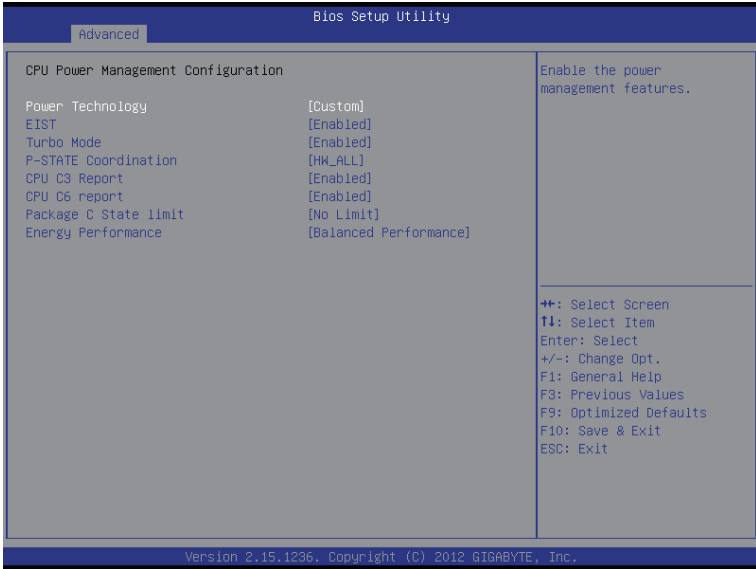

### ☞ CPU Power Management Configuration

#### ☞ Power Technology

Configure the power management features.

Options available: Disable/Energy Efficient/Custom. Default setting is **Custom**.

#### ☞ EIST (Enhanced Intel SpeedStep Technology)

Conventional Intel SpeedStep Technology switches both voltage and frequency in tandem between high and low levels in response to processor load.

Options available: Enabled/Disabled. Default setting is **Enabled**.

#### ☞ Turbo Mode

When this item is enabled, the processor will automatically ramp up the clock speed of 1-2 of its processing cores to improve its performance.

When this item is disabled, the processor will not overclock any of its core.

Options available: Enabled/Disabled. Default setting is **Enabled**.

#### ☞ P-STATE Coordination

In HW\_ALL mode, the processor hardware is responsible for coordinating the P-state among logical processors dependencies. The OS is responsible for keeping the P-state request up to date on all logical processors.

In SW\_ALL mode, the OS Power Manager is responsible for coordinating the P-state among logical processors with dependencies and must initiate the transition on all of those Logical Processors.

In SW\_ANY mode, the OS Power Manager is responsible for coordinating the P-state among logical processors with dependencies and may initiate the transition on any of those Logical Processors.

Options available: HW\_ALL/SW\_ALL/SW\_ANY. Default setting is **HW\_ALL**.

### ☞ CPU C3/C6 Report <sup>(Note)</sup>

Allows you to determine whether to let the CPU enter C3/C6 mode in system halt state. When enabled, the CPU core frequency and voltage will be reduced during system halt state to decrease power consumption. The C3/C6 state is a more enhanced power-saving state than C1.

Options available: Enabled/Disabled. Default setting is **Enabled**.

### ☞ Package C State Limit

Configure state for the C-State package limit.

Options available: C0/C1/C6/C7/No Limit. Default setting is **No Limit**.

### ☞ Energy Performance

Energy Performance Bias is Intel CPU function.

The larger value in MSR\_ENERGY\_PERFORMANCE\_BIAS register, CPU will save more power but lose more performance.

**Note:** This register will be changed by OS too if OS support it like Windows 2008 or newer Linux.

Options available:

Performance : Write value 0 into MSR\_ENERGY\_PERFORMANCE\_BIAS

Balanced Performance: Write value 7 into MSR\_ENERGY\_PERFORMANCE\_BIAS

Balanced Energy: Write value 11 into MSR\_ENERGY\_PERFORMANCE\_BIAS

Energy Efficient: Write value 15 into MSR\_ENERGY\_PERFORMANCE\_BIAS

Default setting is **Performance**.

(Note) This item is present only if you install a CPU that supports this feature. For more information about Intel CPUs' unique features, please visit Intel's website.

## 2-2-4 USB Configuration



### ☞ USB Configuration

### ☞ Legacy USB Support

Enables or disables support for legacy USB devices.

Options available: Auto/Enabled/Disabled. Default setting is **Enabled**.

### ☞ EHCI Hand-off

Enable/Disable EHCI (USB 2.0) Hand-off function.

Options available: Enabled/Disabled. Default setting is **Disabled**.

## 2-2-5 SATA Configuration

Bios Setup Utility

Advanced

SATA Configuration

SATA Port0	Not Present	▲ (1) IDE Mode. (2) AHCI Mode. (3) RAID Mode.  ++: Select Screen ↑↓: Select Item Enter: Select +/-: Change Opt. F1: General Help F8: Previous Values F9: Optimized Defaults F10: Save & Exit ESC: Exit ▼
SATA Port1	Not Present	
SATA Port2	Not Present	
SATA Port3	Not Present	
SATA Port4	Not Present	
SATA Port5	Not Present	
SATA Mode	[AHCI Mode]	
Aggressive Link Power Management	[Enabled]	
Port 0 Hot Plug	[Disabled]	
Port 1 Hot Plug	[Disabled]	
Port 2 Hot Plug	[Disabled]	
Port 3 Hot Plug	[Disabled]	
Port 4 Hot Plug	[Disabled]	
Port 5 Hot Plug	[Disabled]	
External SATA Port 0	[Disabled]	
External SATA Port 1	[Disabled]	
External SATA Port 2	[Disabled]	
External SATA Port 3	[Disabled]	
External SATA Port 4	[Disabled]	
External SATA Port 5	[Disabled]	

Version 2.15.1236. Copyright (C) 2012 GIGABYTE, Inc.

Bios Setup Utility

Advanced

SATA Port5	Not Present	▲ AHCI Supports Staggered Spin-up  ++: Select Screen ↑↓: Select Item Enter: Select +/-: Change Opt. F1: General Help F8: Previous Values F9: Optimized Defaults F10: Save & Exit ESC: Exit ▼
SATA Mode	[AHCI Mode]	
Aggressive Link Power Management	[Enabled]	
Port 0 Hot Plug	[Disabled]	
Port 1 Hot Plug	[Disabled]	
Port 2 Hot Plug	[Disabled]	
Port 3 Hot Plug	[Disabled]	
Port 4 Hot Plug	[Disabled]	
Port 5 Hot Plug	[Disabled]	
External SATA Port 0	[Disabled]	
External SATA Port 1	[Disabled]	
External SATA Port 2	[Disabled]	
External SATA Port 3	[Disabled]	
External SATA Port 4	[Disabled]	
External SATA Port 5	[Disabled]	
Staggered Spin-up	[Disabled]	
Staggered Spin-up	[Disabled]	
Staggered Spin-up	[Disabled]	
Staggered Spin-up	[Disabled]	
Staggered Spin-up	[Disabled]	
Staggered Spin-up	[Disabled]	

Version 2.15.1236. Copyright (C) 2012 GIGABYTE, Inc.

## ☞ **SATA Configuration**

### ☞ **SATA Port 0/1/2/3/4/5** (Note)

Displays the installed HDD devices information. System will automatically detect HDD type.

### ☞ **SATA Mode Selection**

Select the on chip SATA type.

**RAID Mode:** When set to RAID, the SATA controller enables both its RAID and AHCI functions. You will be allowed access to the RAID setup utility at boot time.

**AHCI Mode:** When set to AHCI, the SATA controller enables its AHCI functionality. Then the RAID function is disabled and cannot be accessed through the RAID setup utility at boot time.

Options available: RAID/AHCI/Disabled. Default setting is **AHCI Mode**.

### ☞ **Aggressive Link Power Management**

Enable PCH to aggressively enter link power state.

Options available: Enabled/Disabled. Default setting is **Enabled**.

### ☞ **Hot Plug (for Serial SATA Port 0/1/2/3/4/5)**

Enable/Disable Hot Plug support for Serial ATA Port 0/1/2/3/4/5.

Options available: Enabled/Disabled. Default setting is **Disabled**.

### ☞ **External SATA (for Serial SATA Port 0/1/2/3/4/5)**

Enable/Disable External SATA support for Serial ATA Port 0/1/2/3/4/5.

Options available: Enabled/Disabled. Default setting is **Disabled**.

### ☞ **SATA Device Type (for Serial SATA Port 0/1)**

Define the SATA Device for Serial ATA Port 0/1.

Options available: Hard Disk Drive/Solid State Drive. Default setting is **Disabled**.

### ☞ **Straggered Spin Up (for Serial SATA Port 0/1/2/3/4/5)**

On an edge detect from 0 to 1, the PCH starts a COMreset initialization to the device.

Options available: Enabled/Disabled. Default setting is **Disabled**.

(Note) This item will not appear when the SATA mode is set to RAID mode.

## 2-2-6 Info Report Configuration



### ☞ Info Report Configuration

#### ☞ Post Report

#### ☞ Post Report

Enable/Disable Post Report support.

Options available: Enabled/Disabled. Default setting is **Enabled**.

#### ☞ Error Message Report

#### ☞ Info Error Message

Enable/Disable Info Error Message support.

Options available: Enabled/Disabled. Default setting is **Disabled**.

## 2-2-7 Super IO Configuration



☞ **Super IO Configuration**

☞ **Super IO Chip**

Display the model name of Super IO chipset.

☞ **Serial Port 0 Configuration**

☞ **Serial Port**

When enabled allows you to configure the serial port settings. When set to Disabled, displays no configuration for the serial port.

Options available: Enabled/Disabled. Default setting is **Enabled**.

☞ **Device Settings**

Displays the Serial Port base I/O address and IRQ.

☞ **Change Settings**

Change Serial Port 0 device settings. When set to Auto allows the server's BIOS or OS to select a configuration.

Options available: Auto/I/O=3F8; IRQ=4/I/O=3F8h; IRQ=3,4,5,6,7,10,11,12/

IO=2F8h; IRQ=3,4,5,6,7,10,11,12 /IO=3E8h; IRQ=3,4,5,6,7,10,11,12/IO=2E8h; IRQ=3,4,5,6,7,10,11,12.



## 2-2-8 Serial Port Console Redirection

Bios Setup Utility	
Advanced	
COM1 Console Redirection [Enabled]	Console Redirection Enable or Disable.
▶ Console Redirection Settings	
Serial Port for Out-of-Band Management/ Windows Emergency Management Services (EMS) Console Redirection [Enabled]	
▶ Console Redirection Settings	
SOL Switch [Disabled]	
++: Select Screen ↑↓: Select Item Enter: Select +/-: Change Opt. F1: General Help F8: Previous Values F9: Optimized Defaults F10: Save & Exit ESC: Exit	
Version 2.15.1236. Copyright (C) 2012 GIGABYTE, Inc.	

Bios Setup Utility		
Advanced		
COM1 Console Redirection Settings	Emulation: ANSI: Extended ASCII char set. VT100: ASCII char set. VT100+: Extends VT100 to support color, function keys, etc. VT-UTF8: Uses UTF8 encoding to map Unicode chars onto 1 or more bytes.	
Terminal Type [ANSI]		
Bits per second [115200]	++: Select Screen ↑↓: Select Item Enter: Select +/-: Change Opt. F1: General Help F8: Previous Values F9: Optimized Defaults F10: Save & Exit ESC: Exit	
Data Bits [8]		
Parity [None]		
Stop Bits [1]		
Flow Control [None]		
VT-UTF8 Combo Key Support [Enabled]		
Recorder Mode [Disabled]		
Resolution 100x31 [Disabled]		
Legacy OS Redirection Resolution [80x24]		
Putty KeyPad [VT100]		
Redirection After BIOS POST [Always Enable]		
Version 2.15.1236. Copyright (C) 2012 GIGABYTE, Inc.		

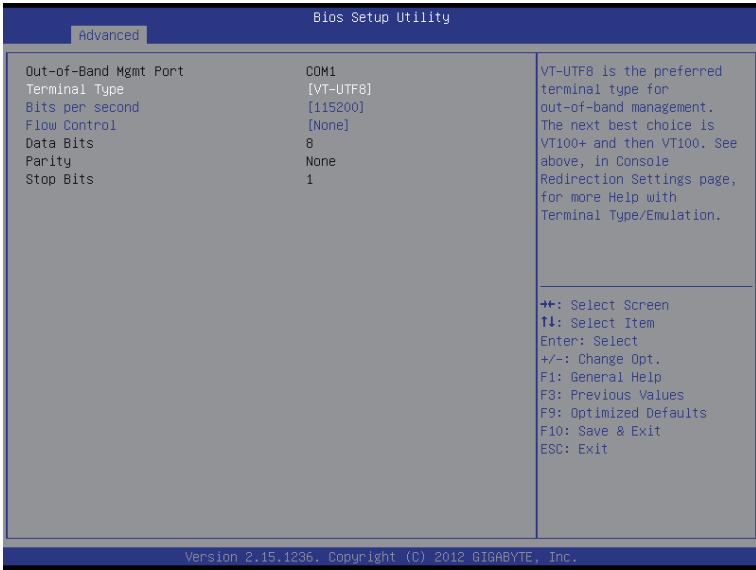

## ☞ COM1/Serial Port for Out-of Band Management / Windows Emergency Management Service (EMS)

### ☞ Console Redirection <sup>(Note)</sup>

Select whether to enable console redirection for specified device. Console redirection enables users to manage the system from a remote location.

Options available: Enabled/Disabled. Default setting is **Disabled**.

### ☞ Console Redirection Settings

#### ☞ Terminal Type

Select a terminal type to be used for console redirection.

Options available: VT100/VT100+/ANSI /VT-UTF8.

#### ☞ Bits per second

Select the baud rate for console redirection.

Options available: 9600/19200/57600/115200.

#### ☞ Data Bits

Select the data bits for console redirection.

#### ☞ Flow Control

Flow control can prevent data loss from buffer overflow. When sending data, if the receiving buffers are full, a 'stop' signal can be sent to stop the data flow. Once the buffers are empty, a 'start' signal can be sent to re-start the flow. Hardware flow control uses two wires to send start/stop signals.

Options available: None/Hardware RTS/CTS.

Options available: 7/8.

(Note) Advanced items prompt when this item is defined.

## ☞ Parity

A parity bit can be sent with the data bits to detect some transmission errors.

Even: parity bit is 0 if the num of 1's in the data bits is even.

Odd: parity bit is 0 if num of 1's the data bits is odd.

Mark: parity bit is always 1. Space: Parity bit is always 0.

Mark and Space Parity do not allow for error detection.

Options available: None/Even/Odd/Mark/Space.

## ☞ Stop Bits

Stop bits indicate the end of a serial data packet. (A start bit indicates the beginning). The standard setting is 1 stop bit. Communication with slow devices may require more than 1 stop bit.

Options available: 1/2.

## ☞ VT-UTF8 Combo Key Support <sup>(Note)</sup>

Enable/Disable VT-UTF8 Combo Key Support.

Options available: Enabled/Disabled. Default setting is **Enabled**.

## ☞ Recorder Mode <sup>(Note)</sup>

When this mode enabled, only text will be send. This is to capture Terminal data.

Options available: Enabled/Disabled.

## ☞ Resolution 100x31 <sup>(Note)</sup>

Enables or disables extended terminal resolution.

Options available: Enabled/Disabled.

## ☞ Legacy OS Redirection Resolution <sup>(Note)</sup>

On Legacy OS, the number of Rows and Columns supported redirection.

Options available: 80x24/80X25.

## ☞ Putty KeyPad <sup>(Note)</sup>

Select function FunctionKey and KeyPad on Putty.

Options available: VT100/LINUX/XTERMR6/SCO/ESCN/VT400.

## ☞ Out-of-Bnad Mgmt Port

Microsoft Windows Emergency Management Service (EMS) allows for remote management of a Windows Server OS through a serial port.

Options available: COM1.

## ☞ SOL Switch

When enabled, COM1 Switch to AST2300 SOL UART.

When disabled, COM1 Switch to IT8728 SOL UART.

Options available: Enabled/Disabled. Default setting is **Disabled**.

(Note) The item is only available for COM1.

## 2-2-9 Network Stack



### Network stack

Enable/Disable UEFI network stack.

Options available: Enabled/Disabled. Default setting is **Disabled**.

## 2-2-10 Intel (R) I350 Gigabit Network Connection

Bios Setup Utility

Advanced

PORT CONFIGURATION MENU  
▶ NIC Configuration

Blink LEDs (range 0-15 seconds) 0

PORT CONFIGURATION INFORMATION  
UEFI Driver: Intel(R) PRO/1000 5.3.00 PCI  
Adapter PBA: 120808-003  
Chip Type: Intel i350  
PCI Device ID 1521  
PCI Bus:Device:Function: 8:0:0  
Link Status [Disconnected]  
Factory MAC Address: 90:2B:34:D2:8C:84  
Alternate MAC Address: 90:2B:34:D2:8C:84

Click to configure the network device port.

++: Select Screen  
↑↓: Select Item  
Enter: Select  
+/-: Change Opt.  
F1: General Help  
F3: Previous Values  
F9: Optimized Defaults  
F10: Save & Exit  
ESC: Exit

Version 2.15.1236. Copyright (C) 2012 GIGABYTE, Inc.

Bios Setup Utility

Advanced

PORT CONFIGURATION MENU  
▶ NIC Configuration

Blink LEDs (range 0-15 seconds) 0

PORT CONFIGURATION INFORMATION  
UEFI Driver: Intel(R) PRO/1000 5.3.00 PCI  
Adapter PBA: 120808-003  
Chip Type: Intel i350  
PCI Device ID 1521  
PCI Bus:Device:Function: 8:0:1  
Link Status [Disconnected]  
Factory MAC Address: 90:2B:34:D2:8C:85  
Alternate MAC Address: 90:2B:34:D2:8C:85

Click to configure the network device port.

++: Select Screen  
↑↓: Select Item  
Enter: Select  
+/-: Change Opt.  
F1: General Help  
F3: Previous Values  
F9: Optimized Defaults  
F10: Save & Exit  
ESC: Exit

Version 2.15.1236. Copyright (C) 2012 GIGABYTE, Inc.

☞ **PORT CONFIGURATION MENU**

☞ **NIC Configuration**

☞ **Link Speed**

Change link speed duplex for current port.

Options available: AutoNeg/10Mbps Half/10Mbps Half/10Mbps Half/100Mbps Full.

Default setting is **AutoNeg**.

☞ **Wake On LAN**

Enable/Disable Wake On LAN feature.

Options available: Enabled/Disabled. Default setting is **Enabled**.

☞ **Blink LEDs (range 0-15 seconds)**

Blink LEDs for the specified duration (up to 15 seconds).

Press the numeric keys to input the desired value.

☞ **Link Status**

Display the link status.

☞ **Factory MAC Address/Alternate MAC Address**

Display the Factory and Alternate MAC address information.

## 2-3 Chipset Menu

The Chipset menu display submenu options for configuring the function of North Bridge and South Bridge. Select a submenu item, then press Enter to access the related submenu screen.



## 2-3-1 North Bridge

Chipset

Bios Setup Utility

IOH Configuration Page

IOH Configuration

QPI Configuration

Compatibility RID [Enabled]

Memory Configuration

Total Memory 4096 MB (DDR3)

Current Memory Mode Independent

Current Memory Speed 1333 MHz

Mirroring Not Possible

Sparing Not Possible

Memory Mode [Independent]

Numa [Enabled]

MPST Support [Disabled]

DDR Speed [Auto]

Channel Interleaving [Auto]

Rank Interleaving [Auto]

Patrol Scrub [Enabled]

Demand Scrub [Disabled]

Data Scrambling [Enabled]

Device Tagging [Disabled]

Rank Margin [Disabled]

++: Select Screen  
 ↑↓: Select Item  
 Enter: Select  
 +/-: Change Opt.  
 F1: General Help  
 F8: Previous Values  
 F9: Optimized Defaults  
 F10: Save & Exit  
 ESC: Exit

Version 2.15.1236. Copyright (C) 2012 GIGABYTE, Inc.

Chipset

Bios Setup Utility

Display DIMM presence and Size information.

Compatibility RID [Enabled]

Memory Configuration

Total Memory 4096 MB (DDR3)

Current Memory Mode Independent

Current Memory Speed 1333 MHz

Mirroring Not Possible

Sparing Not Possible

Memory Mode [Independent]

Numa [Enabled]

MPST Support [Disabled]

DDR Speed [Auto]

Channel Interleaving [Auto]

Rank Interleaving [Auto]

Patrol Scrub [Enabled]

Demand Scrub [Disabled]

Data Scrambling [Enabled]

Device Tagging [Disabled]

Rank Margin [Disabled]

Thermal Throttling [CLTT]

OLTT Peak BW % 50

Altitude [300 M]

DIMM Information

++: Select Screen  
 ↑↓: Select Item  
 Enter: Select  
 +/-: Change Opt.  
 F1: General Help  
 F8: Previous Values  
 F9: Optimized Defaults  
 F10: Save & Exit  
 ESC: Exit

Version 2.15.1236. Copyright (C) 2012 GIGABYTE, Inc.



### ☞ **IOH Configuration**

Press [Enter] for configuration of advanced items.

### ☞ **QPI Configuration**

Press [Enter] for configuration of advanced items.

### ☞ **Compatibility RID**

Enable/Disable Compatibility RID function.

Options available: Enabled/Disabled. Default setting is **Enabled**.

### ☞ **Memory Configuration**

#### ☞ **Total Memory**

Displays the total capacity of the installed memory.

#### ☞ **Current Memory Mode**

Displays the current memory mode. Memory mode can be determined in **Memory Mode** item.

#### ☞ **Current Memory Speed**

Displays the current memory speed.

#### ☞ **Memory Mode**

Determine the memory mode.

When set to Independent mode, all DIMMs are available to the operation system.

When set to Mirroring mode, the motherboard maintains two identical (redundant) copies of all data in memory.

When set to Lockstep mode, the motherboard uses two areas of memory to run the same set of operations in parallel.

When set to Sparing mode, a preset threshold of correctable errors is used to trigger fail-over.

The spare memory is put online and used as active memory in place of the failed memory.

Options available: Independent /Mirroring/ Lockstep/Sparing.

#### ☞ **Numa**

Enable/Disable Non Uniform Memory Access (NUMA) function.

Options available: Enabled/Disabled. Default setting is **Enabled**.

#### ☞ **MPST Support**

Enable/Disable MPST Support function.

Options available: Enabled/Disabled. Default setting is **Disabled**.

#### ☞ **DDR Speed**

Configure the DDR Speed.

Options available: Auto/Force DDR3 800/Force DDR3 1066/Force DDR3 1333/Force DDR3 1600/Force DDR3 1866. Default setting is **Auto**.

#### ☞ **Channel interleaving**

Configure DDR Channel Interleaving.

Options available: Auto/1 Way/2 Way/3 Way/4 Way. Default setting is **Auto**.

#### ☞ **Rank interleaving**

Configure DDR Rank Interleaving. This improves memory performance by masking the refresh cycles of each memory bank. The Rank Interleaving works between different physical banks.

Options available: Auto/1 Way/2 Way/3 Way/4 Way. Default setting is **Auto**.

#### ☞ **Patrol Scrub**

Enable/Disable Patrol Scrub function.

Options available: Enabled/Disabled. Default setting is **Enabled**.

☞ **Demand Scrub**

Enable/Disable Demand Scrub function.

Options available: Enabled/Disabled. Default setting is **Disabled**.

☞ **Device Tagging**

Enable/Disable Device Tagging function.

Options available: Enabled/Disabled. Default setting is **Disabled**.

☞ **Rank Margin**

Enable/Disable Rank Margin function.

Options available: Enabled/Disabled. Default setting is **Disabled**.

☞ **Thermal Thortting**

Configure the Thermal Thortting.

Options available: Disabled/OLTT/CLTT. Default setting is **CLTT**.

☞ **OLTT Peak BW %**

Press the numeric keys to increase or decrease the desired values.

☞ **Altitude**

Configure the Altitude value.

Options available: Auto/300 M/900 M/1500 M/3000 M. Default setting is **3000 M**.

## 2-3-1-1 IOH Configuration

Bios Setup Utility

Chipset

<p>▶ Intel(R) VT for Directed I/O Configuration</p> <p>Intel(R) I/OAT [Disabled]          DCA Support [Enabled]          VGA Priority [Offboard]          TargetVGA Vga From CPU 0          Gen3 Equalization MA's [Disabled]          IOH Resource Selection Type [Auto]          No Snoop Optimization [VC1]          MMIOH Size [64G]          MMCFG BASE [0x80000000]</p>	<p>Intel(R) VT for Directed I/O Configuration</p> <hr/> <p>++: Select Screen          ↑↓: Select Item          Enter: Select          +/-: Change Opt.          F1: General Help          F8: Previous Values          F9: Optimized Defaults          F10: Save &amp; Exit          ESC: Exit</p>
---	--

Version 2.15.1236, Copyright (C) 2012 GIGABYTE, Inc.

Bios Setup Utility

Chipset

<p>Intel(R) VT-d [Enabled]</p>	<p>Enable/Disable Intel(R) Virtualization Technology for Directed I/O.</p> <hr/> <p>++: Select Screen          ↑↓: Select Item          Enter: Select          +/-: Change Opt.          F1: General Help          F8: Previous Values          F9: Optimized Defaults          F10: Save &amp; Exit          ESC: Exit</p>
--------------------------------	---

Version 2.15.1236, Copyright (C) 2012 GIGABYTE, Inc.

- ☞ **IOH Configuration**
- ☞ **Intel(R) VT for Directed I/O Configuration**  
Press [Enter] for configuration of advanced items.
- ☞ **Intel(R) I/OAT (Intel I/O Acceleration Technology)**  
Enable/Disable Intel I/OAT function.  
Options available: Enabled/Disabled. Default setting is **Disabled**.
- ☞ **DCA Support (Direct Cache Access)**  
Enable/Disable Intel DCA Support function.  
Options available: Enabled/Disabled. Default setting is **Disabled**.
- ☞ **VGA Priority**  
Define the display device priority.  
Options available: Onboard/Offboard. Default setting is **Offboard**.
- ☞ **Gen3 Equalization WA's**  
Enable/Disable the support for Gen3 Equalization Workaround.  
Options available: Enabled/Disabled. Default setting is **Disabled**.
- ☞ **IOH Resource Seletion Type**  
Configure IOH Resource Seletion Type.  
Options available: Auto/Manual. Default setting is **Auto**.
- ☞ **No Snoop Optimization**  
Options VC0/VCP/VC1. Default setting is **VC1**.
- ☞ **MMCFG Size (Size of the Memory Mapped Configuration Space)**  
Options available: 1G/2G/4G/8G/16G/32G/64G. Default setting is **64G**.
- ☞ **MMCFGBASE (Base address of the Memory Mapped Configuration Space)**  
Options available: 0x80000000/0xA0000000/0xC0000000/0x40000000. Default setting is **0x80000000**.
- ☞ **Intel(R) VT-d**  
Enable/Disable Intel VT-d Technology function.  
Options available: Enabled/Disabled. Default setting is **Enabled**.

## 2-3-1-2 QPI Configuration

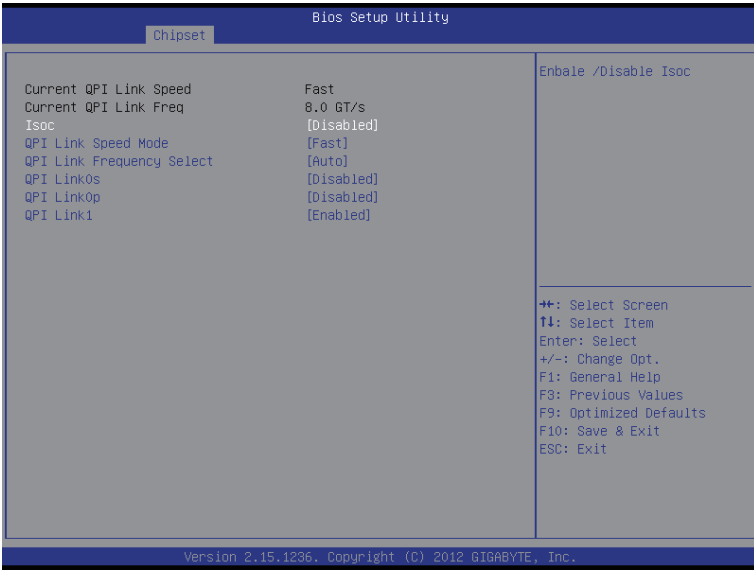

### ☞ **Current QPI Link Speed/ Current QPI Link Freq**

Displays the current QPI Link Speed and Frequency information.

### ☞ **Isoc**

Enable/Disable Isoc.

Options available: Enabled/Disabled. Default setting is **Disabled**.

### ☞ **QPI Link Speed Mode**

Configure QPI Link Speed mode.

Options available: Fast/Slow. Default setting is **Fast**.

### ☞ **QPI Link Frequency Select**

Configure QPI Link Frequency.

Options available: Auto/6.4 GT/s/7.2 GT/s/8.6 GT/s. Default setting is **Auto**.

### ☞ **QPI Link0s**

Options available: Enabled/Disabled. Default setting is **Disabled**.

### ☞ **QPI Link0p**

Options available: Enabled/Disabled. Default setting is **Disabled**.

### ☞ **QPI Link1**

Options available: Enabled/Disabled. Default setting is **Enabled**.

## 2-3-1-3 DIMM Information

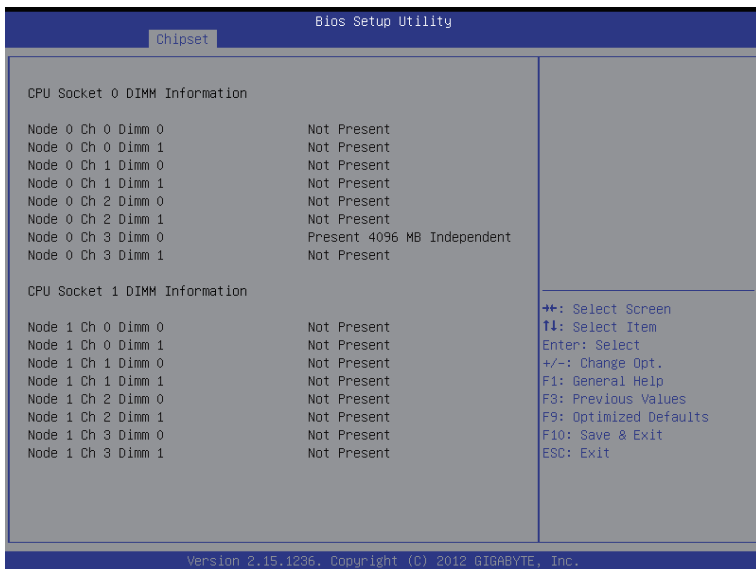

### ☞ CPU Socket 0/1 DIMM Information

#### ☞ CPU Socket 0:

#### ☞ DDR3\_P0\_A0/DDR3\_P0\_A1/DDR3\_P0\_B0/DDR3\_P0\_B1 Status

#### ☞ DDR3\_P0\_C0/DDR3\_P0\_C1/DDR3\_P0\_D0/DDR3\_P0\_D1 Status

The size of memory installed on each of the DDR3 slots.

#### ☞ CPU Socket 1:

#### ☞ DDR3\_P0\_E0/DDR3\_P0\_E1/DDR3\_P0\_F0/DDR3\_P0\_F1 Status

#### ☞ DDR3\_P0\_G0/DDR3\_P0\_G1/DDR3\_P0\_H0/DDR3\_P0\_H1 Status

The size of memory installed on each of the DDR3 slots.

## 2-3-2 South Bridge Configuration

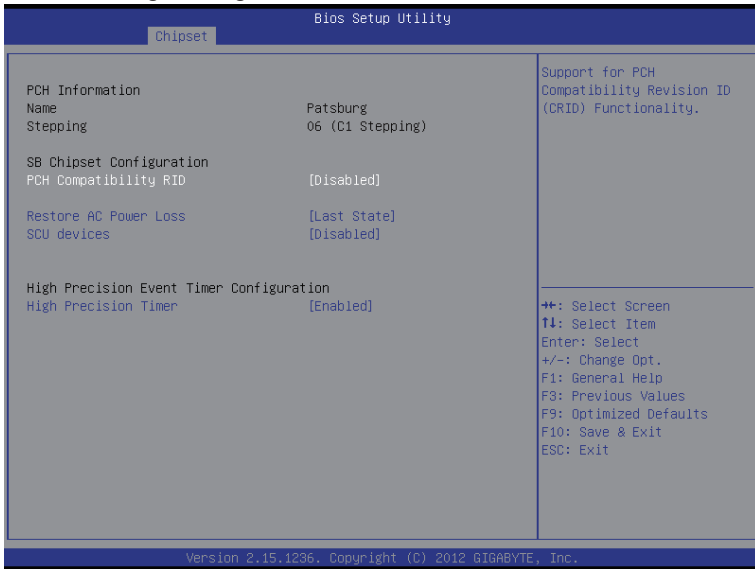

### ☞ PCH Information

### ☞ Name/Stepping Information

Displays the name and stepping information of the south bridge.

### ☞ SB Chipset Configuration

### ☞ PCH Compatibility RID

Enable/Disable PCH Compatibility RID support.

Options available: Enabled/Disabled. Default setting is **Disabled**.

### ☞ Restore on AC Power Loss <sup>(Note)</sup>

Defines the power state to resume to after a system shutdown that is due to an interruption in AC power. When set to Last State, the system will return to the active power state prior to shutdown. When set to Stay Off, the system remains off after power shutdown.

Options available: Last State/Stay Off/Power On. The default setting depends on the BMC setting.

### ☞ SCU Devices

Enable/Disable Patsburg SCU device.

Options available: Enabled/Disabled. Default setting is **Disabled**.

### ☞ High Precision Event Timer Configuration

### ☞ High Precision Event Timer

Enable/Disable High Precision Event Timer.

Options available: Enabled/Disabled. Default setting is **Enabled**.

(Note) When the power policy is controlled by BMC, please wait for 15-20 seconds for BMC to save the last power state.

### 2-3-3 Intel ME Subsystem

Bios Setup Utility	
Chipset	
Intel ME Subsystem Configuration	ME Subsystem Help
ME Subsystem	[Enabled]
ME BIOS Interface Version	1.2
ME Version	2.1.7.129
ME FW Status Value :	0xf0345
ME FW State :	SPS ME FW Active
ME FW Operation State :	M0 without UMA
ME FW Error Code :	No Error
ME Ext FW Status Value :	0x39000301
BIOS Booting Mode :	Performance Optimized mode
Cores Disabled :	0
ME FW SKU Information :	SiEn NM
End-of-POST Status :	EOP disabled in POST
	<b>++:</b> Select Screen <b>F1:</b> Select Item <b>Enter:</b> Select <b>+/-:</b> Change Opt. <b>F1:</b> General Help <b>F8:</b> Previous Values <b>F9:</b> Optimized Defaults <b>F10:</b> Save & Exit <b>ESC:</b> Exit

Version 2.15.1236. Copyright (C) 2012 GIGABYTE, Inc.

#### ME Subsystem Configuration

Enable/Disable ME subsystem configuration.

Options available: Enabled/Disabled. Default setting is **Enabled**.



## 2-4 Security Menu

The Security menu allows you to safeguard and protect the system from unauthorized use by setting up access passwords.



There are two types of passwords that you can set:

- **Administrator Password**  
Entering this password will allow the user to access and change all settings in the Setup Utility.
- **User Password**  
Entering this password will restrict a user's access to the Setup menus. To enable or disable this field, a Administrator Password must first be set. A user can only access and modify the System Time, System Date, and Set User Password fields.

### 🔑 Administrator Password

Press Enter to configure the Administrator password.

### 🔑 User Password

Press Enter to configure the user password.

## 2-4-1 Secure Boot menu (Optional)

The Secure Boot Menu is applicable when your device is installed the Windows® 8 operatin system.

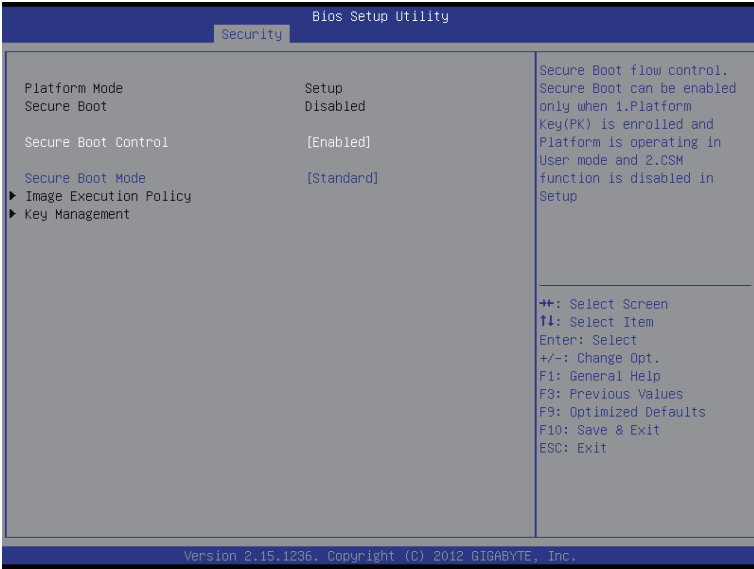

### ☞ Secure Boot menu

### ☞ Platform Mode

Display the System Platform Mode State.

### ☞ Secure Boot

Display the status of Secure Boot.

### ☞ Secure Boot Control

Enable/Disable Secure Boot function.

Options available: Enabled/Disabled. Default setting is **Enabled**.

### ☞ Secure Boot Mode

Secure Boot requires all the applications that are running during the booting process to be pre-signed with valid digital certificates. This way, the system knows all the files being loaded before Windows 8 loads and gets to the login screen have not been tampered with.

When set to Standard, it will automatically load the Secure Boot keys form the BIOS databases.

When set to Custom, you can customize the Secure Boot settings and manually load its keys from the BIOS database.

Options available: Standard/Custom. Default setting is **Standard**.

## 2-4-1-1 Image Execution Policy



### Image Execution policy

#### Internal FV

Image Execution Policy per device path on Security Violation.

Options available: Always Execute. Default setting is **Always Execute**.

#### Option ROM

Image Execution Policy per device path on Security Violation.

Options available: Always Execute/Always Deny/Allow Execute/Defer Execute/ Deny Execute/ Query User. Default setting is **Deny Execute**.

#### Removable Media

Image Execution Policy per device path on Security Violation.

Options available: Always Execute/Always Deny/Allow Execute/Defer Execute/ Deny Execute/ Query User. Default setting is **Deny Execute**.

#### Fixed Media

Image Execution Policy per device path on Security Violation.

Options available: Always Execute/Always Deny/Allow Execute/Defer Execute/ Deny Execute/ Query User. Default setting is **Deny Execute**.

## 2-4-1-2 Key Management

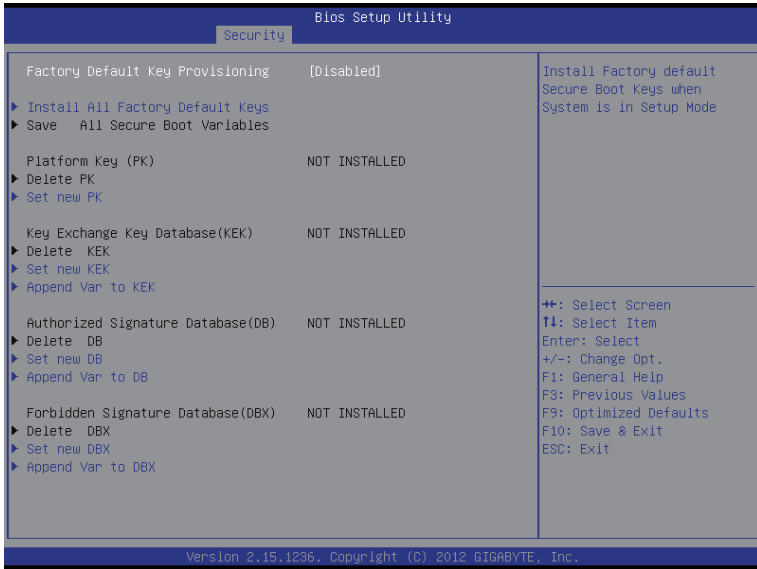

### 🔑 Key Management

This item appears only when the **Secure Boot Mode** is set to **Custom**.

### 🔑 Default Key Provisioning

Force the system to Setup Mode. This will clear all Secure Boot Variables such as Platform Key (PK), Key-exchange Key (KEK), Authorized Signature Database (db), and Forbidden Signatures Database (dbx).

Options available: Enabled/Disabled. Default setting is **Disabled**.

### 🔑 Install default Secure Boot Keys

Press [Enter] to install default Secure Boot Keys.

### 🔑 Platform Key (PK)

Display the status of Platform Key.

### 🔑 Set PK from File

Press [Enter] to configure a new PK.

### 🔑 Get PK from File

Press [Enter] to configure the existed PK.

### 🔑 Delete the PK

Press [Enter] to delete the existed PK. Once the PK is deleted, all the system's Secure Boot keys will not be activated.

### 🔑 Key Exchange Key Database (KEK)

Display the status of Platform Key.

### 🔑 Set new KEK from File

Press [Enter] to configure a new KEK.

☞ **Get new KEK from File**

Press [Enter] to configure the existed KEK.

☞ **Delete KEK**

Press [Enter] to delete the KEK from your system.

☞ **Append an entry to KEK**

Press [Enter] to load additional KEK from a storage devices for an additional db and dbx management.

☞ **Authorized Signature Database (DB)**

Display the status of Authorized Signature Database.

☞ **Set new DB**

Press [Enter] to configure a new db.

☞ **Get new DB**

Press [Enter] to configure the existed db.

☞ **Delete DB**

Press [Enter] to delete the db from your system.

☞ **Append an entry to DB**

Press [Enter] to load additional db from a storage devices.

☞ **Forbidden Signature Database (DBX)**

Display the status of Forbidden Signature Database.

☞ **Set DBX from File**

Press [Enter] to configure a new dbx.

☞ **Get DBX to File**

Press [Enter] to configure the existed dbx.

☞ **Delete the DBX**

Press [Enter] to delete the dbx from your system.

☞ **Append and entry to DBX**

Press [Enter] to load additional db from a storage devices.

## 2-5 Server Management Menu



### ☞ **BMC LAN Configuration**

BMC LAN Configuration. Press Enter to access the related submenu.

### ☞ **Gbt BMC Function**

BMC related function configuration. Press Enter to access the related submenu.

### ☞ **View FRU information**

The FRU information submenu is a simple display page for basic system ID information, as well as system product information. Items on this window are non-configurable.

### ☞ **System Event Log**

Displays Event Log advanced settings. Press Enter to access the related submenu.

## 2-5-1 BMC LAN Configuration

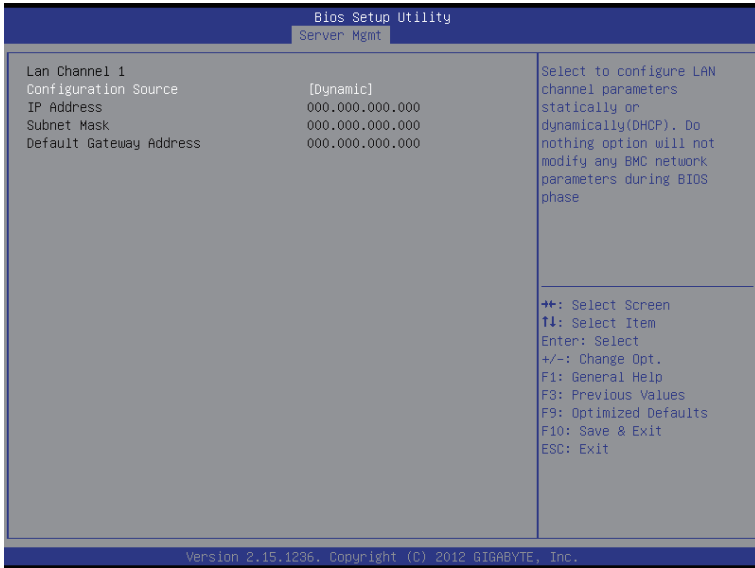

### ☞ Lan Channel 1

### ☞ Configuration Source

Select to configure LAN channel parameters statically or dynamically (DHCP). Do nothing option will not modify any BMC network parameters during BIOS phase.

Options available: Static/Dynamic/Do Nothing.

### ☞ IP Address

Display IP Address information.

### ☞ Subnet Mask

Display Subnet Mask information.

Please note that the IP address must be in three digitals, for example, 192.168.000.001.

### ☞ Default Gateway Address

Display Default Gateway Address information.

## 2-5-2 Gbt BMC Function

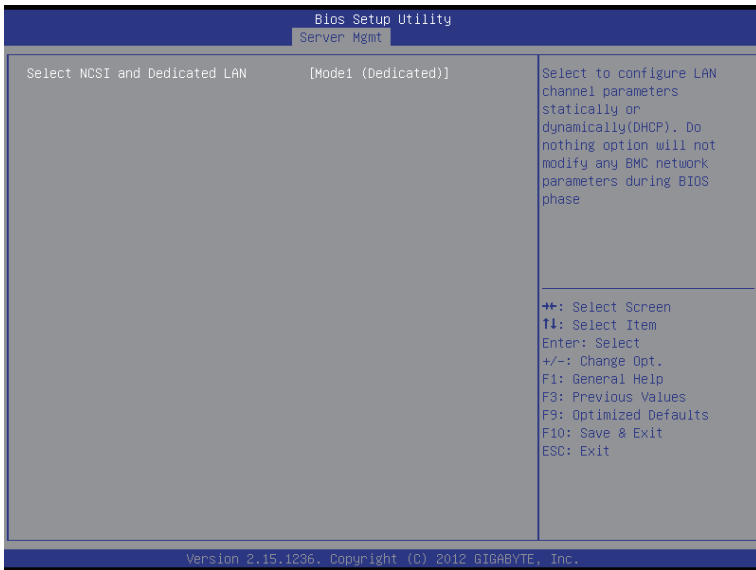

### ☞ Select NCSI and Dedicated LAN

Switch NCSI and dedicated LAN and send KCS command.

Options available: Mode2(NSCI)/ Mode1 (Dedicated). Default setting is **Mode1 (Dedicated)**.



### 2-5-3 View FRU Information

The System Management submenu is a simple display page for basic system ID information, as well as System product information. Items on this window are non-configurable.

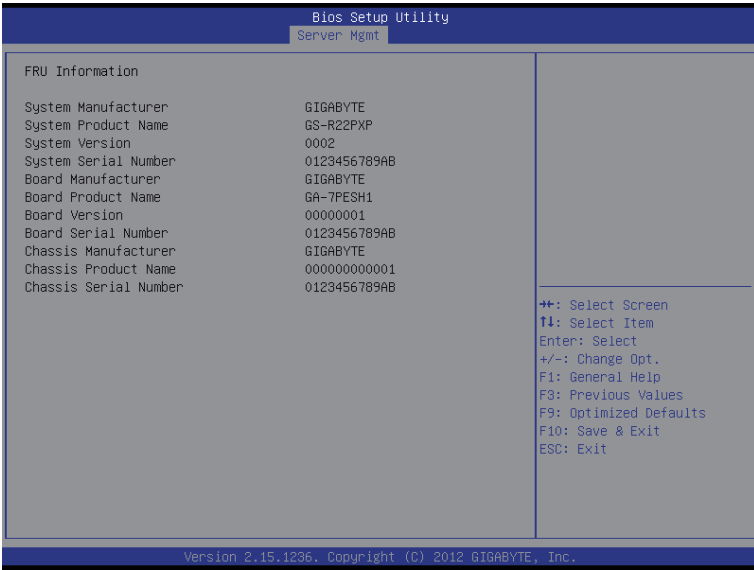

## 2-5-4 System Event Log

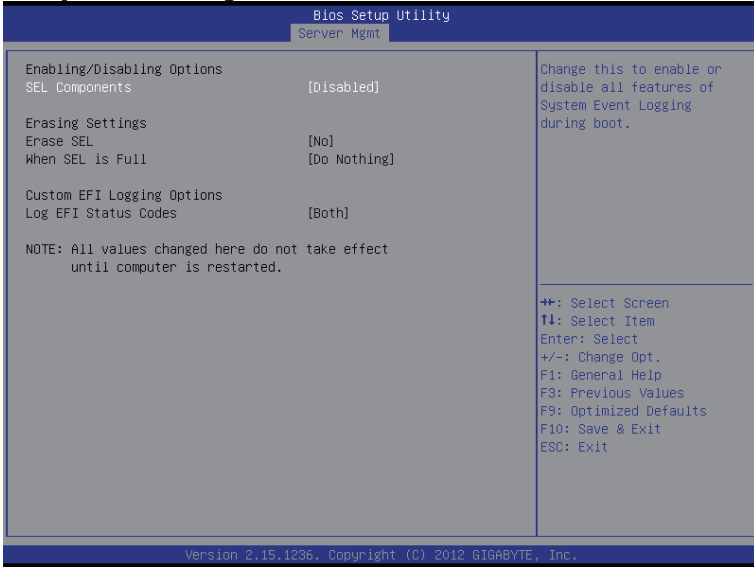

### ☞ Enabling/Disabling Options

### ☞ SEL Components

Change this to enable or disable all features of System Event Logging during boot.  
Options available: Enabled/Disabled. Default setting is **Enabled**.

### ☞ Erasing Settings

### ☞ Erasing SEL

Choose options for erasing SEL.  
Options available: No/Yes, On next reset/Yes, On every reset. Default setting is **No**.

### ☞ When SEL is Full

Choose options for reactions to a full SEL.  
Options available: Do Nothing/Erase Immediately. Default setting is **Do Nothing**.

### ☞ Custom EFI Logging Options

### ☞ Log EFI Status Codes

Enable/Disable the logging of EFI Status Codes (if not already converted to legacy).  
Options available: Disabled/Both/Error code/Progress code. Default setting is **Both**.

## 2-6 Boot Menu

The Boot menu allows you to set the drive priority during system boot-up. BIOS setup will display an error message if the legacy drive(s) specified is not bootable.

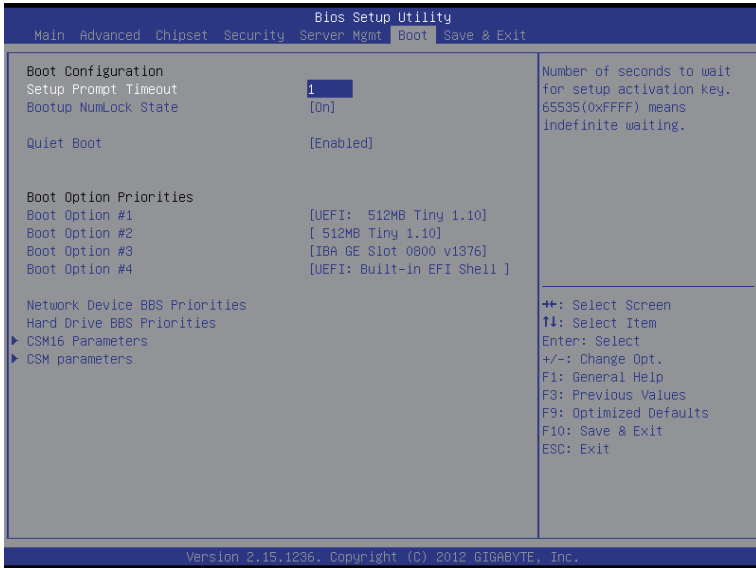

### ☞ Boot Configuration

### ☞ Setup Prompt Timeout

Number of seconds to wait for setup activation key. 65535(0xFFFF) means indefinite waiting." Press the numeric keys to input the desired value.

### ☞ Bootup NumLock State

Enable or Disable Bootup NumLock function.  
Options available: On/Off. Default setting is **On**.

### ☞ Quiet Boot

Enables or disables showing the logo during POST.  
Options available: Enabled/Disabled. Default setting is **Enabled**.

### ☞ Boot Priority Order

### ☞ Boot Option #1/#2/#3/#4

Press Enter to configure the boot priority.  
By default, the server searches for boot devices in the following sequence:

1. UEFI device.
2. Hard drive.
3. Network device.
4. Removable device

☞ **Network Device BBS Priorities**

Press Enter to configure the boot priority.

☞ **Hard Drive BBS Priorities**

Press Enter to configure the boot priority.

☞ **CSM16 Parameters**

Press Enter to configure the CSM16 parameters.

☞ **CSM Parameters**

Press Enter to configure the CSM parameters.

## 2-6-1 CSM16 Parameters

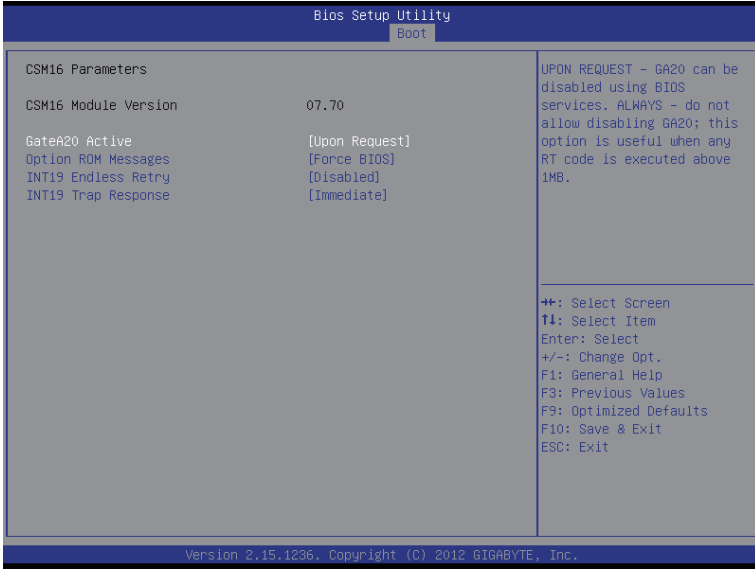

### ☞ CSM16 Parameters

### ☞ CSM16 Module Version

Display CSM Module version information.

### ☞ Gate20 Active

Upon Request: GA20 can be disabled using BIOS services.

Always: Do not allow disabling GA20; this option is useful when any RT code is executed above 1MB.

Options available: Upon Request/Always. Default setting is **Upon Request**.

### ☞ Option ROM Messages

Option ROM Messages.

Options available: Force BIOS/Keep Current. Default setting is **Force BIOS**.

### ☞ INT19 Endless Retry

Enabled: Allowed headless retry boot

Options available: Enabled/Disabled. Default setting is **Disabled**.

### ☞ INT19 Trap Response

BIOS reaction on INT19 trapping by Option ROM

Immediate: execute the trap right away.

Postpone: execute the trap during legacy boot.

Options available: Immediate/Postpone. Default setting is **Immediate**.

## 2-6-2 CSM Parameters

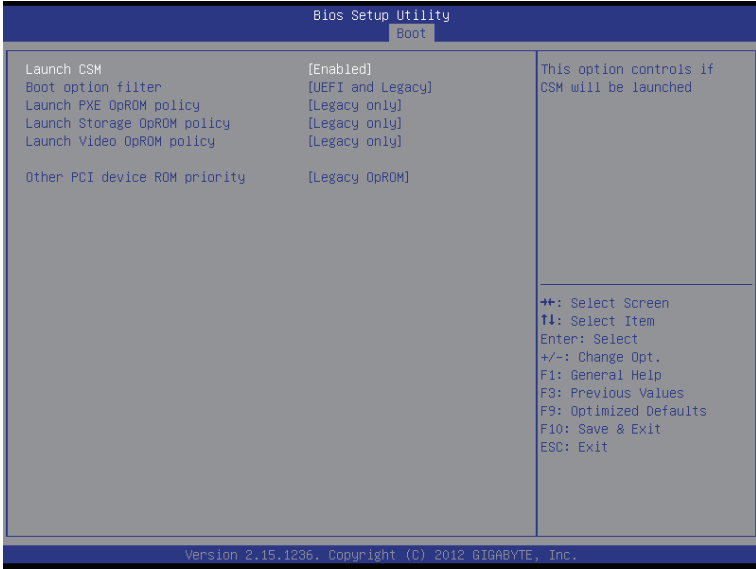

### ☞ CSM parameters

Press Enter to configure the advanced items.

### ☞ Launch CSM (Compatibility Support Module)

Enable/Disable Compatibility Support Module (CSM) launch.

Options available: Enabled/Disabled. Default setting is **Enabled**.



- The following five items appears and configurable when the **Launch CSM** is set to **Enabled**.
- If the **Launch CSM** is set to **Disabled**, the following five items will not be able to support Legacy mode.

### ☞ Boot option filter

Determines which devices system will boot to.

Options available: UEFI and Legacy/Legacy only/UEFI only. Default setting is **UEFI and Legacy**.

### ☞ Launch PXE OpROM policy

Determines which devices system will boot to.

Options available: Do not launch/UEFI only/Legacy only/Legacy first/UEFI first. Default setting is **Do not launch**.

### ☞ Launch Storage OpROM policy

Determines which devices system will boot to.

Options available: Do not launch/UEFI only/Legacy only/Legacy first/UEFI first. Default setting is **Legacy only**.

### ☞ Launch Video OpROM policy

Determines which devices system will boot to.

Options available: Do not launch/UEFI only/Legacy only/Legacy first/UEFI first. Default setting is **Legacy only**.

### Other PCI device ROM priority

For PCI devices other than Network, Mass storage or Video device, defines which OpROM to launch. Options available: UEFI OpROM/Legacy OpROM. Default setting is **UEFI OpROM**.

## 2-7 Exit Menu

The Exit menu displays the various options to quit from the BIOS setup. Highlight any of the exit options then press **Enter**.

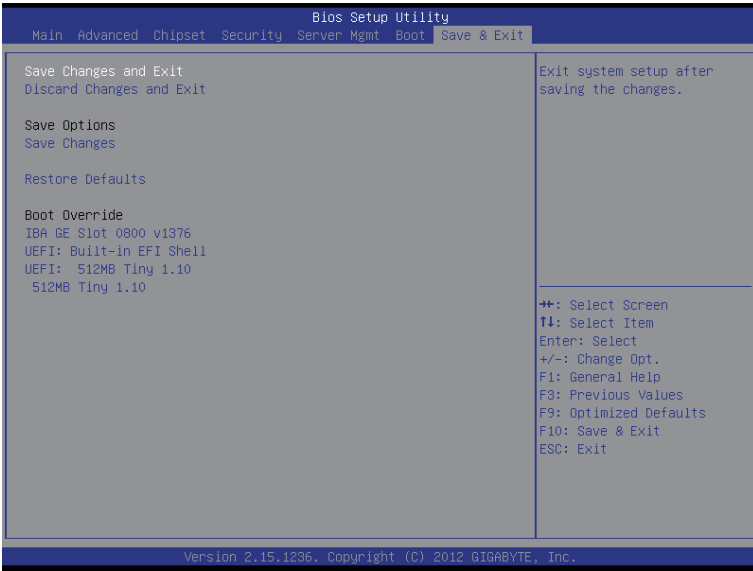

### ☞ **Save Changes and Exit**

Saves changes made and close the BIOS setup.

Options available: Yes/No.

### ☞ **Discard Changes and Exit**

Discards changes made and close the BIOS setup.

Options available: Yes/No.

### ☞ **Save Options**

### ☞ **Save Changes**

Saves changes made in the BIOS setup.

Options available: Yes/No.

### ☞ **Restore Defaults**

Loads the default settings for all BIOS setup parameters. Setup Defaults are quite demanding in terms of resources consumption. If you are using low-speed memory chips or other kinds of low-performance components and you choose to load these settings, the system might not function properly.

Options available: Yes/No.

### ☞ **Boot Override**

Press Enter to configure the device as the boot-up drive.

### ☞ **UEFI: Built-in in EFI Shell**

Press <Enter> on this item to Launch EFI Shell from filesystem device.



# Chapter 3 Appendix

## 3-1 Regulatory Statements

### Regulatory Notices

This document must not be copied without our written permission, and the contents there of must not be imparted to a third party nor be used for any unauthorized purpose. Contravention will be prosecuted. We believe that the information contained herein was accurate in all respects at the time of printing. GIGABYTE cannot, however, assume any responsibility for errors or omissions in this text. Also note that the information in this document is subject to change without notice and should not be construed as a commitment by GIGABYTE.

### Our Commitment to Preserving the Environment

In addition to high-efficiency performance, all GIGABYTE motherboards fulfill European Union regulations for RoHS (Restriction of Certain Hazardous Substances in Electrical and Electronic Equipment) and WEEE (Waste Electrical and Electronic Equipment) environmental directives, as well as most major worldwide safety requirements. To prevent releases of harmful substances into the environment and to maximize the use of our natural resources, GIGABYTE provides the following information on how you can responsibly recycle or reuse most of the materials in your "end of life" product.

### Restriction of Hazardous Substances (RoHS) Directive Statement

GIGABYTE products have not intended to add and safe from hazardous substances (Cd, Pb, Hg, Cr+6, PBDE and PBB). The parts and components have been carefully selected to meet RoHS requirement. Moreover, we at GIGABYTE are continuing our efforts to develop products that do not use internationally banned toxic chemicals.

### Waste Electrical & Electronic Equipment (WEEE) Directive Statement

GIGABYTE will fulfill the national laws as interpreted from the 2002/96/EC WEEE (Waste Electrical and Electronic Equipment) directive. The WEEE Directive specifies the treatment, collection, recycling and disposal of electric and electronic devices and their components. Under the Directive, used equipment must be marked, collected separately, and disposed of properly.

### WEEE Symbol Statement



The symbol shown below is on the product or on its packaging, which indicates that this product must not be disposed of with other waste. Instead, the device should be taken to the waste collection centers for activation of the treatment, collection, recycling and disposal procedure.

The separate collection and recycling of your waste equipment at the time of disposal will help to conserve natural resources and ensure that it is recycled in a manner that protects human health and the environment. For more information about where you can drop off your waste equipment for recycling, please contact your local government office, your household waste disposal service or where you purchased the product for details of environmentally safe recycling.

- ◆ When your electrical or electronic equipment is no longer useful to you, "take it back" to your local or regional waste collection administration for recycling.
- ◆ If you need further assistance in recycling, reusing in your "end of life" product, you may contact us at the Customer Care number listed in your product's user's manual and we will be glad to help you with your effort.

Finally, we suggest that you practice other environmentally friendly actions by understanding and using the energy-saving features of this product (where applicable), recycling the inner and outer packaging (including shipping containers) this product was delivered in, and by disposing of or recycling used batteries properly. With your help, we can reduce the amount of natural resources needed to produce electrical and electronic equipment, minimize the use of landfills for the disposal of "end of life" products, and generally improve our quality of life by ensuring that potentially hazardous substances are not released into the environment and are disposed of properly.