

GA-7PESH3

Dual LGA2011 sockets motherboard for Intel® E5-2600 series processors

User's Manual

Rev. 1001

Copyright

© 2013 GIGA-BYTE TECHNOLOGY CO., LTD. All rights reserved.

The trademarks mentioned in this manual are legally registered to their respective owners.

Disclaimer

Information in this manual is protected by copyright laws and is the property of GIGABYTE.

Changes to the specifications and features in this manual may be made by GIGABYTE without prior notice. No part of this manual may be reproduced, copied, translated, transmitted, or published in any form or by any means without GIGABYTE's prior written permission.

Documentation Classifications

In order to assist in the use of this product, GIGABYTE provides the following types of documentations:

- For detailed product information, carefully read the User's Manual.

For product-related information, check on our website at:

<http://www.gigabyte.com>

Table of Contents

Box Contents	5
GA-7PESH3 Motherboard Layout	6
Chapter 1 Hardware Installation	9
1-1 Installation Precautions	9
1-2 Product Specifications	10
1-3 Installing the CPU and CPU Cooler	13
1-3-1 Installing the CPU	13
1-3-2 Installing the CPU Cooler	15
1-4 Installing the Memory	16
1-4-1 Four Channel Memory Configuration	16
1-4-2 Installing a Memory	17
1-4-3 DIMM Population Table	17
1-5 Back Panel Connectors	18
1-6 Internal Connectors	20
1-7 Jumper Settings	35
Chapter 2 BIOS Setup	41
2-1 The Main Menu	43
2-2 Advanced Menu	45
2-2-1 PCI Configuration	46
2-2-2 ACPI Settings	47
2-2-3 Trusted Computing (Optional)	48
2-2-4 CPU Configuration	49
2-2-4-1 CPU Power Management Configuration	52
2-2-5 Runtime Error Logging	53
2-2-6 SATA Configuration	54
2-2-7 Super IO Configuration	55
2-2-8 Serial Port Console Redirection	57
2-3 Chipset Menu	60
2-3-1 North Bridge Configuration	61
2-3-1-1 IOH Configuration	63
2-3-1-2 DIMM Information	66
2-3-2 South Bridge Configuration	67
2-3-3 ME Subsystem	68
2-4 Security Menu	69
2-5 Server Management Menu	70
2-5-1 System Information	71

2-5-2	BMC LAN Configuration	72
2-6	Boot Option Menu	73
2-7	Boot Manager.....	75
2-8	Exit Menu	76
Chapter 3	Appendix	78
3-1	Regulatory Statements.....	78

Box Contents

- GA-7PESH3 Motherboard
- Driver CD
- Two SATA cables
- I/O Shield
- CPU Power cables

- The box contents above are for reference only and the actual items shall depend on the product package you obtain. The box contents are subject to change without notice.
- The motherboard image is for reference only.

GA-7PESH3 Motherboard Layout

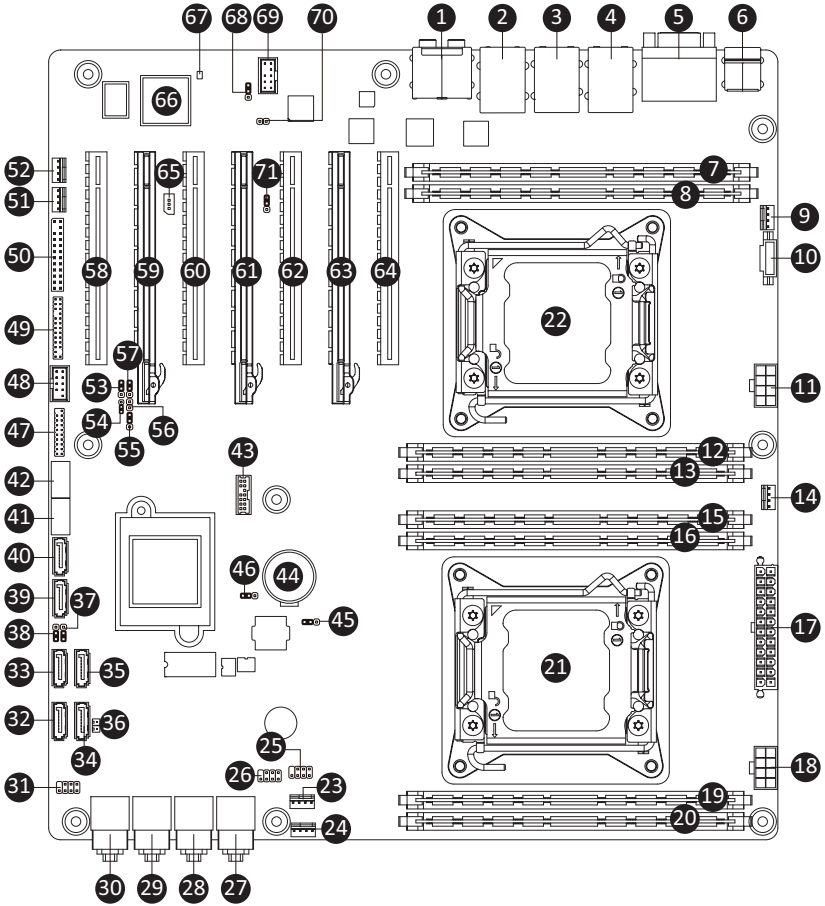

Item	Code	Description
1	AUDIO1	Audio connectors
2	USB_MLAN	BMC Management LAN port (top) / USB ports (bottom)
3	USB_GLAN1	LAN1 port (top) / USB ports (bottom)
4	USB_GLAN2	LAN2 port (top) / USB ports (bottom)
5	COM1_VGA1	Serial port (top) / VGA port (bottom)
6	USB_PS2	USB ports (top) / PS/2 connector (bottom)
7	DDR3_P1_E0	Channel 1 slot 0 (for secondary CPU)
8	DDR3_P1_F0	Channel 2 slot 0 (for secondary CPU)
9	CPU1_FAN	CPU1 fan connector
10	PWR_DET1	PMBus connector
11	P12V_AUX2	8 pin power connector
12	DDR3_P1_H0	Channel 4 slot 0 (for secondary CPU)
13	DDR3_P1_G0	Channel 3 slot 0 (for secondary CPU)
14	CPU0_FAN	CPU0 fan connector
15	DDR3_P0_A0	Channel 1 slot 0 (for primary CPU)
16	DDR3_P0_B0	Channel 2 slot 0 (for primary CPU)
17	ATX1	24 pin power connector
18	P12V_AUX1	8 pin power connector
19	DDR3_P0_D0	Channel 4 slot 0 (for primary CPU)
20	DDR3_P0_C0	Channel 3 slot 0 (for primary CPU)
21	CPU0	Intel LGA2011 socket (Primary CPU)
22	CPU1	Intel LGA2011 socket (Secondary CPU)
23	SYS_FAN1	System fan connector #1
24	SYS_FAN2	System fan connector #2
25	SAS_SGPIO2	SAS SGPIO header #2
26	SAS_SGPIO1	SAS SGPIO header #1
27	SAS01	SAS 6Gb/s connectors
28	SAS23	SAS 6Gb/s connectors
29	SAS45	SAS 6Gb/s connectors
30	SAS67	SAS 6Gb/s connectors
31	SATA_SGPIO	SATA SGPIO header
32	SATA0	SATA 6Gb/s connector
33	SATA1	SATA 6Gb/s connector
34	SATA2	SATA 3Gb/s connector
35	SATA3	SATA 3Gb/s connector
36	RAIDKEY1	LSI RAID key header
37	SATA_DOM1	SATA port 1 DOM support jumper
38	SATA_DOM0	SATA port 0 DOM support jumper
39	SATA4	SATA 3Gb/s connector
40	SATA5	SATA 3Gb/s connector
41	USB_A2	Type A USB 3.0 connector #2
42	USB_A1	Type A USB 3.0 connector #1
43	TPM_1	TPM module connector
44	BAT1	Battery socket

45	BIOS_WP1	BIOS write protect jumper
46	CLR_CMOS1	Clear CMOS jumper
47	F_USB3_1	USB 3.0 connector
48	FRONT_USB	USB 2.0 connector
49	BP_1	HDD back plane board header
50	F_PANEL1	Front pannel header
51	SYS_FAN4	System fan connector #4
52	SYS_FAN3	System fan connector #4
53	PASSWORD1	Skip supervisor paswword jumper
54	S3_MASK	S3 Power On Select jumper
55	SSB_ME1	ME recovery jumper
56	CHASSIS_OP	Chassis intrusion header
57	BIOS_RVCR1	BIOS recovery jumper
58	PCIE_1	PCI-E slot 1 (x16 slot/Running at x8; shared bandwidth with PCI-E slot 2)
59	PCIE_2	PCI-E slot 2 (x16 slot/Running at x8; shared bandwidth with PCI-E slot 1)
60	PCIE_3	PCI-E slot 3 (x16 slot/Running at x8; shared bandwidth with PCI-E slot 4)
61	PCIE_4	PCI-E slot 4 (x16 slot/Running at x8; shared bandwidth with PCI-E slot 3)
62	PCIE_5	PCI-E slot 5 (x16 slot/Running at x8; shared bandwidth with PCI-E slot 6)
63	PCIE_6	PCI-E slot 6 (x16 slot/Running at x8; shared bandwidth with PCI-E slot 5)
64	PCIE_7	PCI-E slot 7 (x16 slot/Running at x16)
65	IPMB1	IPMB connector
66	U47	ASPEED AST2300
67	BMC_LED1	BMC firmware readiness LED
68	BMC_FRB1	Force to Stop FRB1 Timer jumper
69	FAUDIO_ACZ	Front audio header
70	SPDIF_OUT	S/PDIF Out header
71	PMBUS_SEL	PMBus Power Select jumper



CAUTION! If a SATA type hard drive is connected to the motherboard, please ensure the jumper is closed and set to **2-3 pins** (Normal mode), in order to reduce any risk of hard disk damage. Please refer to Page 38 for SATA_DOM1 and SATA_DOM2 jumper setting instruction.







Chapter 1 Hardware Installation







1-1 Installation Precautions



The motherboard contains numerous delicate electronic circuits and components which can become damaged as a result of electrostatic discharge (ESD). Prior to installation, carefully read the user's manual and follow these procedures:

- Prior to installation, do not remove or break motherboard S/N (Serial Number) sticker or warranty sticker provided by your dealer. These stickers are required for warranty validation.
- Always remove the AC power by unplugging the power cord from the power outlet before installing or removing the motherboard or other hardware components.
- When connecting hardware components to the internal connectors on the motherboard, make sure they are connected tightly and securely.
- When handling the motherboard, avoid touching any metal leads or connectors.
- It is best to wear an electrostatic discharge (ESD) wrist strap when handling electronic components such as a motherboard, CPU or memory. If you do not have an ESD wrist strap, keep your hands dry and first touch a metal object to eliminate static electricity.
- Prior to installing the motherboard, please have it on top of an antistatic pad or within an electrostatic shielding container.
- Before unplugging the power supply cable from the motherboard, make sure the power supply has been turned off.
- Before turning on the power, make sure the power supply voltage has been set according to the local voltage standard.
- Before using the product, please verify that all cables and power connectors of your hardware components are connected.
- To prevent damage to the motherboard, do not allow screws to come in contact with the motherboard circuit or its components.
- Make sure there are no leftover screws or metal components placed on the motherboard or within the computer casing.
- Do not place the computer system on an uneven surface.
- Do not place the computer system in a high-temperature environment.
- Turning on the computer power during the installation process can lead to damage to system components as well as physical harm to the user.
- If you are uncertain about any installation steps or have a problem related to the use of the product, please consult a certified computer technician.

1-2 Product Specifications

	CPU	<ul style="list-style-type: none"> ◆ Support for Intel® Xeon® E5-2600 series processors in the LGA2011 package ◆ L3 cache varies with CPU ◆ Supports QuickPath Interconnect up to 8GT/s ◆ Enhanced Intel SpeedStep Technology (EIST) ◆ Support Intel Virtualization Technology (VT)
	Chipset	<ul style="list-style-type: none"> ◆ Intel® C602 (Patsburg-A) Chipset
	Memory	<ul style="list-style-type: none"> ◆ 8 x 1.35V/1.5V DDR3 DIMM sockets supporting up to 64GB (UDIMM) and 256GB (RDIMM) of system memory ◆ 8 x 1.35V/1.5V DDR3 LRDIMM sockets supporting up to 256GB of system memory ◆ Four channel memory architecture ◆ Support for 800/1066/1333/1600 memory modules ◆ Support for ECC RDIMM/ UDIMM/ LRDIMM memory modules
	LAN	<ul style="list-style-type: none"> ◆ Dual Intel® 82574L supports 10/100/1000 Mbps
	Expansion Slots	<ul style="list-style-type: none"> ◆ 1 x PCI Express x16 slot, running at x16 (Gen3/PCIE_7) ◆ 1 x PCI Express x16 slot, running at x8 (Gen3/PCIE_1/The slot shares bandwidth with the PCIE_2 slot. When PCIE_2 slot is populated, the PCIE_1 will operate at x8 mode.) ◆ 1 x PCI Express x16 slot, running at x8 (Gen3/PCIE_2/Shared bandwidth with PCIE_1 slot) ◆ 1 x PCI Express x16 slot, running at x8 (Gen3/PCIE_3/The slot shares bandwidth with the PCIE_4 slot. When PCIE_4 slot is populated, the PCIE_3 slot will operate at x8 mode.) ◆ 1 x PCI Express x16 slot, running at x8 (Gen3/PCIE_4/Shared bandwidth with PCIE_3 slot) ◆ 1 x PCI Express x16 slot, running at x8 (Gen3/PCIE_5/SThe slot shares bandwidth with the PCIE_6 slot. When PCIE_6 slot is populated, the PCIE_5 slot will operate at x8 mode.) ◆ 1 x PCI Express x16 slot, running at x8 (Gen3/PCIE_6/Shared bandwidth with PCIE_5 slot)
	Onboard Graphics	<ul style="list-style-type: none"> ◆ ASPEED® AST2300 supports 16MB VRAM

	Storage Interface (SATA)	<ul style="list-style-type: none"> ◆ Intel® C602 controller ◆ 2 x SATA 6Gb/s connectors (SATA0/SATA1) ◆ 4 x SATA 3Gb/s connectors (SATA2/SATA3/SATA4/SATA5) ◆ Support for Intel RSTe SATA RAID 0, RAID 1
	Storage Interface (SAS)	<ul style="list-style-type: none"> ◆ LSI 2008 controller ◆ 8 x SAS 6Gb/s connectors (SAS01/SAS23/SAS45/SAS67)
	USB	<ul style="list-style-type: none"> ◆ Up to 6 USB 2.0/1.1 ports (4 on the back panel, 2 additional ports via the USB brackets connected to the internal USB headers) ◆ Up to 8 USB 3.0 ports (4 on the back panel, 2 Type A connector, 2 additional ports via the USB brackets connected to the internal USB headers)
	Internal Connectors	<ul style="list-style-type: none"> ◆ 1 x 24-pin ATX main power connector ◆ 2 x 8-pin ATX 12V power connector ◆ 8 x SAS 6Gb/s connectors ◆ 2 x SATA 6Gb/s connectors ◆ 4 x SATA 3Gb/s connectors ◆ 1 x PMBus header ◆ 2 x CPU fan headers ◆ 4 x System fan headers ◆ 1 x Front panel header ◆ 1 x HDD back plane board header ◆ 2 x SAS SGPIO headers ◆ 1 x USB 2.0/1.1 header ◆ 1 x USB 3.0 header ◆ 2 x USB 3.0 Type A connectors ◆ 1 x TPM module connector ◆ 1 x Front audio header ◆ 1 x RAID KEY header ◆ 1 x S/PDIF Out header
	Rear Panel I/O	<ul style="list-style-type: none"> ◆ 4 x USB 2.0/1.1 ports ◆ 3 x RJ-45 port (1 x 10/100 dedicated management LAN port) ◆ 1 x COM port ◆ 1 x VGA port ◆ 1 x PS/2 connector ◆ 1 x Audio connector (Center/Subwoofer Speaker/Rear Speaker Out/Side Speaker Out/Line In/Line Out/Mic In)
	I/O Controller	<ul style="list-style-type: none"> ◆ ASPEED® AST2300 BMC chip

	Hardware Monitor	<ul style="list-style-type: none"> ◆ System voltage detection ◆ CPU/System temperature detection ◆ CPU/System fan speed detection ◆ CPU/System fan speed control <ul style="list-style-type: none"> * Whether the CPU/system fan speed control function is supported will depend on the CPU/system cooler you install.
	BIOS	<ul style="list-style-type: none"> ◆ 1 x 64 Mbit flash ◆ AMI BIOS
	Form Factor	<ul style="list-style-type: none"> ◆ EATX Form Factor; 12 inch x 13 inch, 10 layers PCB

* GIGABYTE reserves the right to make any changes to the product specifications and product-related information without prior notice.

1-3 Installing the CPU and CPU Cooler



Read the following guidelines before you begin to install the CPU:

- Make sure that the motherboard supports the CPU.
- Always turn off the computer and unplug the power cord from the power outlet before installing the CPU to prevent hardware damage.
- Locate the pin one of the CPU. The CPU cannot be inserted if oriented incorrectly. (Or you may locate the notches on both sides of the CPU and alignment keys on the CPU socket.)
- Apply an even and thin layer of thermal grease on the surface of the CPU.
- Do not turn on the computer if the CPU cooler is not installed, otherwise overheating and damage of the CPU may occur.
- Set the CPU host frequency in accordance with the CPU specifications. It is not recommended that the system bus frequency be set beyond hardware specifications since it does not meet the standard requirements for the peripherals. If you wish to set the frequency beyond the standard specifications, please do so according to your hardware specifications including the CPU, graphics card, memory, hard drive, etc.

1-3-1 Installing the CPU

A. Locate the alignment keys on the motherboard CPU socket and the notches on the CPU.

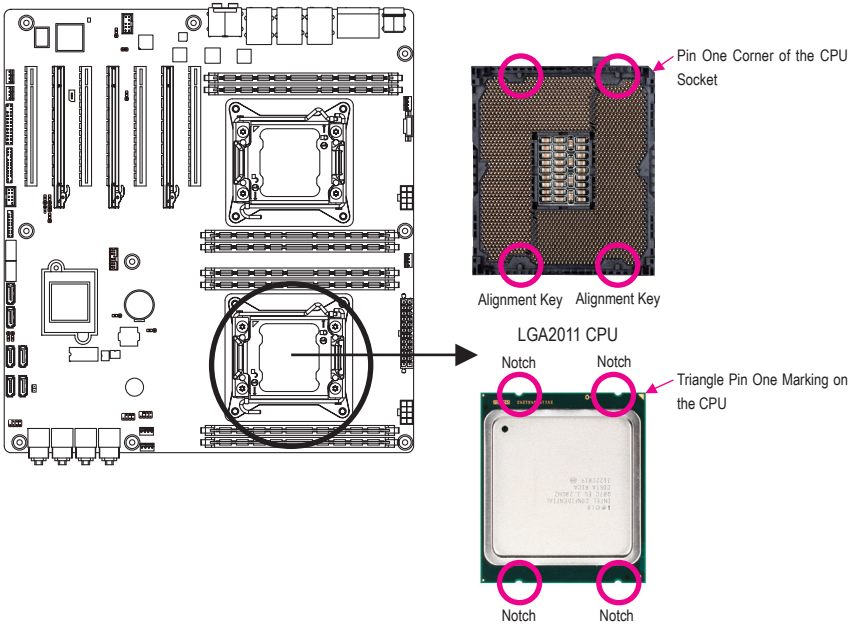

B. Follow the steps below to correctly install the CPU into the motherboard CPU socket.



- Before installing the CPU, make sure to turn off the computer and unplug the power cord from the power outlet to prevent damage to the CPU.
- To protect the socket contacts, do not remove the protective plastic cover unless the CPU is inserted into the CPU socket. Save the cover properly and replace it if the CPU is removed.

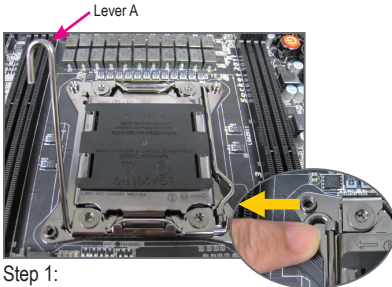

Step 1:

Push the lever closest to the "unlock" marking "☐" (below referred as lever A) down and away from the socket to release it.

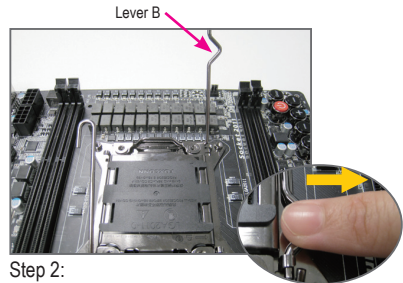

Step 2:

Push the lever closest to the "lock" marking "☒" (below referred as lever B) down and away from the socket. Then lift the lever.



Step 3:

Gently press lever A to allow the load plate to rise. Open the load plate. (Note: DO NOT touch the socket contacts after the load plate is opened.)



Step 4:

Hold the CPU with your thumb and index fingers. Align the CPU pin one marking (triangle) with the pin one corner of the CPU socket (or align the CPU notches with the socket alignment keys) and carefully insert the CPU into the socket vertically.



Step 5:

Once the CPU is properly inserted, carefully replace the load plate. Then secure lever B under its retention tab. The protective plastic cover may pop off from the load plate during the process of engaging the lever. Remove the cover. Save the cover properly and always replace it when the CPU is not installed.



Step 6:

Finally, secure lever A under its retention tab to complete the installation of the CPU.

1-3-2 Installing the CPU Cooler

Refer to the steps below to correctly install the CPU cooler on the motherboard. (Actual installation process may differ depending the CPU cooler to be used. Refer to the user's manual for your CPU cooler.)



Step 1:

Apply an even and thin layer of thermal grease on the surface of the installed CPU.

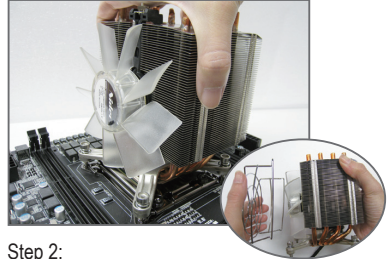

Step 2:

Place the cooler atop the CPU, aligning the four mounting screws with the mounting holes on the ILM. (If your cooler has a fan grill which may cause interference when you tighten the screws, remove it first and replace it after tightening the screws.)

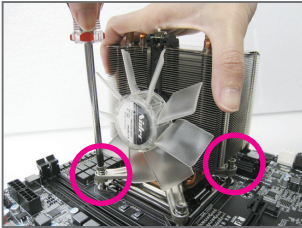

Step 3:

Use one hand to hold the cooler and the other to tighten the screws in a diagonal sequence with a screw driver. Begin tightening a screw with a few turns and repeat with the screw diagonally opposite the one you just tightened. Then do the same to the other pair. Next, fully tighten the four screws.

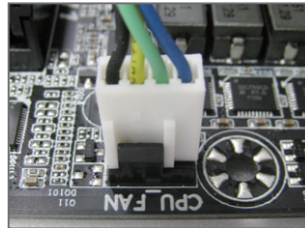

Step 4:

Finally, attach the power connector of the CPU cooler to the CPU fan header (CPU_FAN) on the motherboard.



Please pay more attention when removing the CPU cooler because the thermal grease/tape between the CPU cooler and CPU may adhere to the CPU. Inadequately removing the CPU cooler may damage the CPU.

1-4 Installing the Memory



Read the following guidelines before you begin to install the memory:

- Make sure that the motherboard supports the memory. It is recommended that memory of the same capacity, brand, speed, and chips be used.
(Go to GIGABYTE's website for the latest supported memory speeds and memory modules.)
- Always turn off the computer and unplug the power cord from the power outlet before installing the memory to prevent hardware damage.
- Memory modules have a foolproof design. A memory module can be installed in only one direction. If you are unable to insert the memory, switch the direction.

1-4-1 Four Channel Memory Configuration

This motherboard provides eight DDR3 memory sockets and supports Four Channel Technology. After the memory is installed, the BIOS will automatically detect the specifications and capacity of the memory. Enabling Four Channel memory mode will be four times of the original memory bandwidth.

The four DDR3 memory sockets are divided into four channels each channel has two memory sockets as following:

Channel 1: DDR3_P0_A0 (For primary CPU); DDR3_P1_E0 (For secondary CPU)

Channel 2: DDR3_P0_B0, (For primary CPU); DDR3_P1_F0 (For secondary CPU)

Channel 3: DDR3_P0_C0 (For primary CPU); DDR3_P1_G0 (For secondary CPU)

Channel 4: DDR3_P0_D0 (For primary CPU); DDR3_H1_F0 (For secondary CPU)

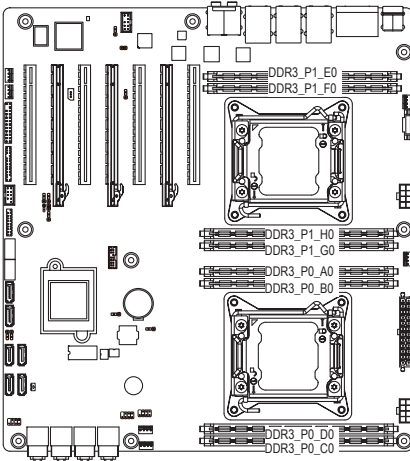

Due to CPU limitations, read the following guidelines before installing the memory in Four Channel mode.

1. Four Channel mode cannot be enabled if only $\begin{matrix} \text{DDR3_P1_F1} \\ \text{DDR3_P1_F0} \end{matrix}$ memory module is installed.
2. When enabling Four Channel mode with two or $\begin{matrix} \text{DDR3_P1_E1} \\ \text{DDR3_P1_E0} \end{matrix}$ memory modules, it is recommended that memory of the same capacity, brand, speed, and chips be used for optimum performance.

1-4-2 Installing a Memory



Before installing a memory module, make sure to turn off the computer and unplug the power cord from the power outlet to prevent damage to the memory module.

Be sure to install DDR3 DIMMs on this motherboard.

Installation Step:

Step 1. Insert the DIMM memory module vertically into the DIMM slot, and push it down.

Step 2. Close the plastic clip at both edges of the DIMM slots to lock the DIMM module.

Note: For dual-channel operation, DIMMs must be installed in matched pairs.

Step 3. Reverse the installation steps when you wish to remove the DIMM module.

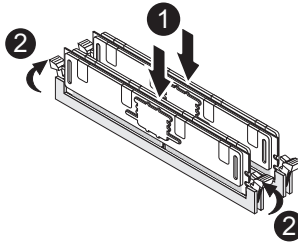

1-4-3 DIMM Population Table

R-DIMM	1N or 2N	DIMM0
	1N	Single-Rank
	1N	Dual-Rank
	1N	Quad-Rank

U-DIMM	1N or 2N	DIMM0
	1N	Single-Rank
	1N	Dual-Rank

1-5 Back Panel Connectors

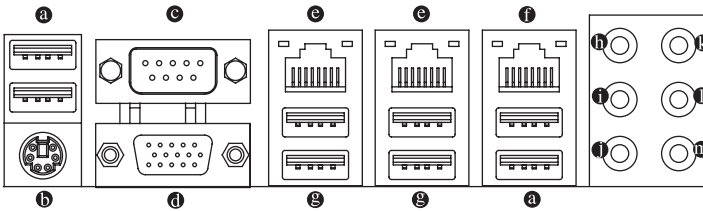

a USB 2.0/1.1 Port

The USB port supports the USB 2.0/1.1 specification. Use this port for USB devices such as a USB keyboard/mouse, USB printer, USB flash drive and etc.

b PS/2 Keyboard/Mouse Port

Connect a PS/2 keyboard or mouse to this port.

c Serial Port

Connects to serial-based mouse or data processing devices.

d Video Port

The video in port allows connect to video in, which can also apply to video loop thru function.

e RJ-45 LAN Port

The Gigabit Ethernet LAN port provides Internet connection at up to 1 Gbps data rate. The following describes the states of the LAN port LEDs.

f KVM Server Management 10/100 LAN Port

The LAN port provides Internet connection with data transfer speeds of 10/100Mbps.

g USB 3.0 Port

The USB port supports the USB 3.0 specification. Use this port for USB devices such as a USB keyboard/mouse, USB printer, USB flash drive and etc.

h Center/Subwoofer Speaker Out Jack (Orange)

Use this audio jack to connect center/subwoofer speakers in a 5.1/7.1-channel audio configuration.

i Rear Speaker Out Jack (Black)

Use this audio jack to connect rear speakers in a 7.1-channel audio configuration.

j Side Speaker Out Jack (Gray)

Use this audio jack to connect side speakers in a 4/5.1/7.1-channel audio configuration.

k Line In Jack (Blue)

The default line in jack. Use this audio jack for line in devices such as an optical drive, walkman, etc.

l Line Out Jack (Green)

The default line out jack. Use this audio jack for a headphone or 2-channel speaker. This jack can be used to connect front speakers in a 4/5.1/7.1-channel audio configuration.

m Mic In Jack (Pink)

The default Mic in jack. Microphones must be connected to this jack.

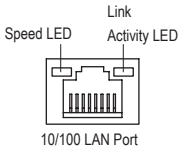

10/100 (MLAN) Speed LED:

State	Description
Green On	100 Mbps data rate
Green Blink	10 Mbps or 100 Mbps data rate
Off	10 Mbps data rate

Link/Activity LED:

State	Description
On	Link between system and network or no access
Blinking	Data transmission or receiving is occurring
Off	No data transmission or receiving is occurring

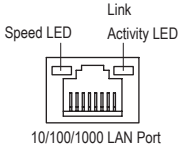

10/100/1000 (GbE) Speed LED:

State	Description
Yellow On	1 Gbps data rate
Yellow Blink	Identify 1 Gbps data rate
Green On	100 Mbps data rate
Green Blink	Identify 100 Mbps data rate
Off	10 Mbps data rate

Link/Activity LED:

State	Description
On	Link between system and network or no access
Blinking	Data transmission or receiving is occurring
Off	No data transmission or receiving is occurring



- When removing the cable connected to a back panel connector, first remove the cable from your device and then remove it from the motherboard.
- When removing the cable, pull it straight out from the connector. Do not rock it side to side to prevent an electrical short inside the cable connector.

1-6 Internal Connectors

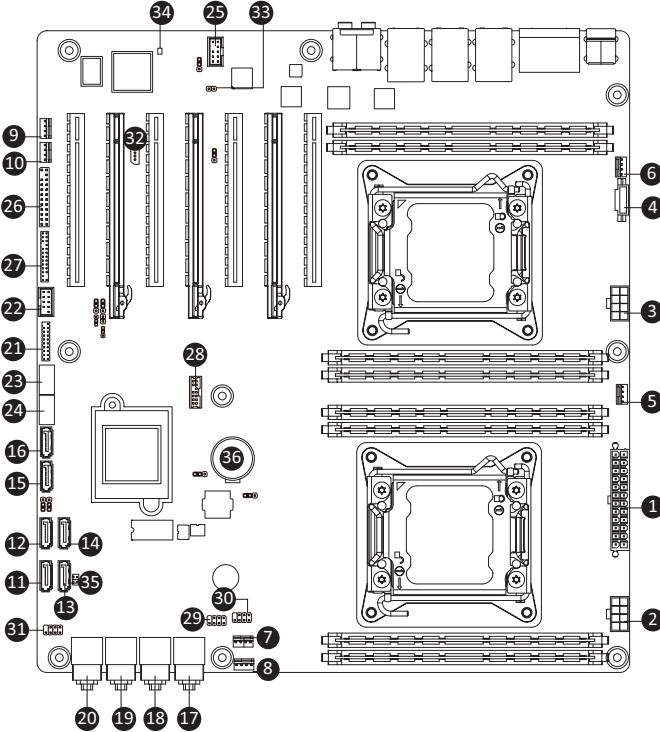

1) ATX1	19) SAS45
2) P12V_AUX1	20) SAS67
3) P12V_AUX2	21) F_USB3_1
4) PWR_DET1 (PMBus)	22) FRONT_USB
5) CPU0_FAN (for primary CPU)	23) USB_A1
6) CPU1_FAN (for secondary CPU)	24) USB_A2
7) SYS_FAN1 (System Fan)	25) FAUDIO_ACZ
8) SYS_FAN2 (System Fan)	26) F_PANEL_1
9) SYS_FAN3 (System Fan)	27) BP_1
10) SYS_FAN4 (System Fan)	28) TPM_1
11) SATA0	29) SAS_SGPIO1
12) SATA1	30) SAS_SGPIO2
13) SATA2	31) SATA_SGPIO
14) SATA3	32) IPMB1
15) SATA4	33) SPDIF_OUT
17) SAS01	34) BMC_LED1
18) SAS23	35) RAIDKEY1
	36) BAT1



Read the following guidelines before connecting external devices:

- First make sure your devices are compliant with the connectors you wish to connect.
- Before installing the devices, be sure to turn off the devices and your computer. Unplug the power cord from the power outlet to prevent damage to the devices.
- After installing the device and before turning on the computer, make sure the device cable has been securely attached to the connector on the motherboard.

1/2/3) ATX1/P12V_AUX1/P12V_AUX2

(2x4 12V Power Connector and 2x12 Main Power Connector)

With the use of the power connector, the power supply can supply enough stable power to all the components on the motherboard. Before connecting the power connector, first make sure the power supply is turned off and all devices are properly installed. The power connector possesses a foolproof design. Connect the power supply cable to the power connector in the correct orientation. The 12V power connector mainly supplies power to the CPU. If the 12V power connector is not connected, the computer will not start.



- If you are using the power supply that split up into several sets of +12V, please attach the power cable (see below picture) to P12V_AUX1 and P12V_AUX2 first, then connect the +12V power connector of the power supply into cable box-header.

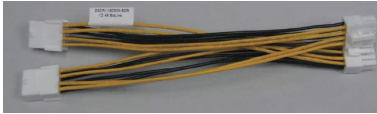

- If you are using the power supply that provide single +12V, just install power supply connectors to P12V_AUX1 and P12V_AUX2 directly.
- To meet expansion requirements, it is recommended that a power supply that can withstand high power consumption be used (1000W / 5V standby 4A or greater). If a power supply is used that does not provide the required power, the result can lead to an unstable or unbootable system.

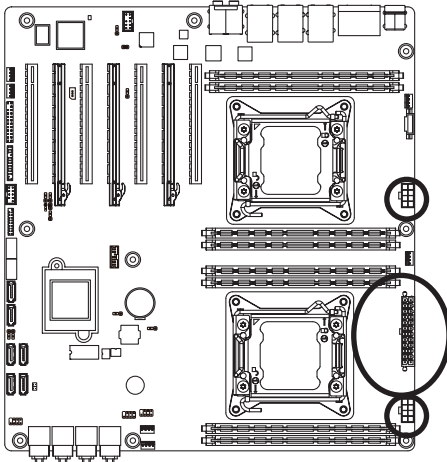

P12V_AUX2

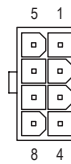

Pin No.	Definition
1	GND
2	GND
3	GND
4	GND
5	+12V
6	+12V
7	+12V
8	+12V

ATX1

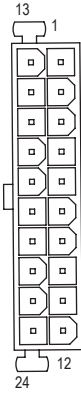

ATX1

Pin No.	Definition	Pin No.	Definition
1	3.3V	13	3.3V
2	3.3V	14	-12V
3	GND	15	GND
4	+5V	16	PS_ON
5	GND	17	GND
6	+5V	18	GND
7	GND	19	GND
8	Power Good	20	-5V
9	5VSB (stand by +5V)	21	+5V
10	+12V	22	+5V
11	+12V	23	+5V
12	3.3V	24	GND

4) PWR_DET1 (PMBus connector)

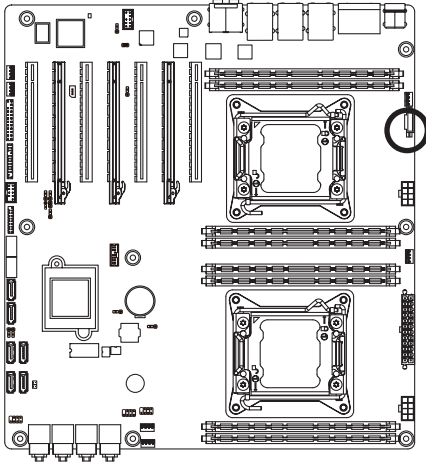

Pin No.	Definition
1	SMB CLK
2	SMB DATA
3	SMB Alert
4	GND
5	3.3V Sense

5/6/7/8/9/10) CPU0_FAN/CPU1_FAN/SYS_FAN1/SYS_FAN2/SYS_FAN3/SYS_FAN4 (CPU Fan/System Fan Headers)

The motherboard has two 4-pin CPU fan headers, four 4-pin system fan headers. Most fan headers possess a foolproof insertion design. When connecting a fan cable, be sure to connect it in the correct orientation (the black connector wire is the ground wire). The motherboard supports CPU fan speed control, which requires the use of a CPU fan with fan speed control design. For optimum heat dissipation, it is recommended that a system fan be installed inside the chassis.

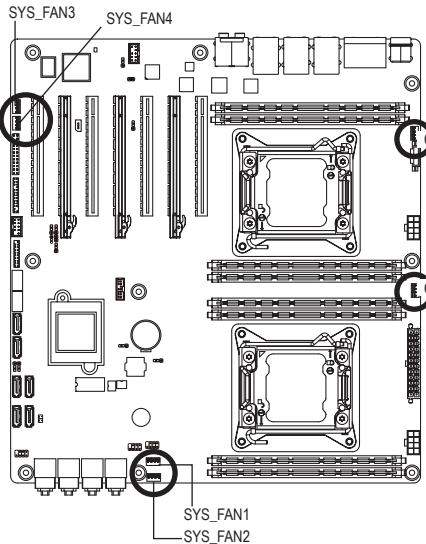

Pin No.	Definition
1	GND
2	+12V
3	Sense
4	Speed Control



- Be sure to connect fan cables to the fan headers to prevent your CPU and system from overheating. Overheating may result in damage to the CPU or the system may hang.
- These fan headers are not configuration jumper blocks. Do not place a jumper cap on the headers.

11/12) SATA0/SATA1 (SATA 6Gb/s Connectors)

The SATA connectors conform to SATA 6Gb/s standard and are compatible with SATA 3Gb/s and 1.5Gb/s standard. Each SATA connector supports a single SATA device.

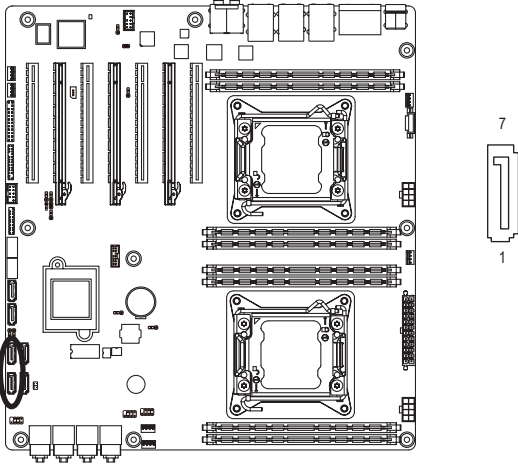

When SATA_DOM0/1 jumper are set to **Normal Mode**:

Pin No.	Definition
1	GND
2	TXP
3	TXN
4	GND
5	RXN
6	RXP
7	GND

When SATA_DOM1/2 Jumper are set to 1-2 pin:

Pin No.	Definition
1	GND
2	TXP
3	TXN
4	GND
5	RXN
6	RXP
7	P5V

13/14/15/16) SATA3/SATA4/SATA5/SATA6 (SATA 3Gb/s Connectors)

The SATA connectors conform to SATA 3Gb/s standard and are compatible with SATA 1.5 Gb/s standard. Each SATA connector supports a single SATA device.

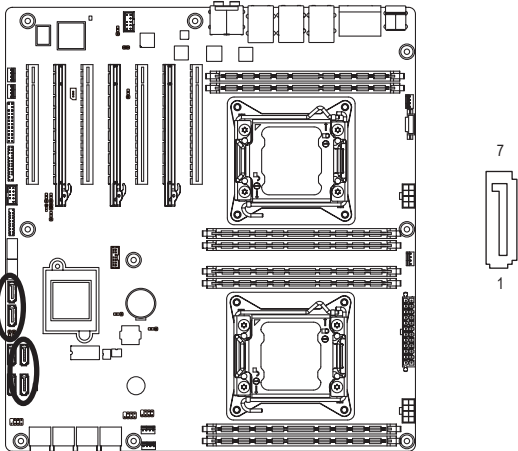

Pin No.	Definition
1	GND
2	TXP
3	TXN
4	GND
5	RXN
6	RXP
7	GND



- A RAID 0 or RAID 1 configuration requires at least two hard drives. If more than two hard drives are configured, the total number of hard drives must be an even number.
- A RAID 10 configuration requires four hard drives.

(Note) When a RAID configuration is built across the SATA 6Gb/s channels, the system performance of the RAID configuration may vary depends on the devices are connected.

17/18/19/20) SAS01/SAS23/SAS45/SAS67 (SAS 6Gb/s Connectors)

The SAS connectors conform to SAS 6Gb/s standard.

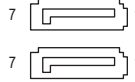
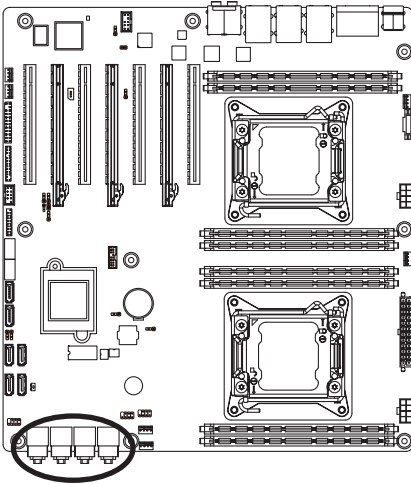

Pin No.	Definition
1	GND
2	TXP
3	TXN
4	GND
5	RXN
6	RXP
7	GND

21) F_USB3_1 (USB 3.0 Header)

The headers conform to USB 3.0 specification. Each USB header can provide two USB ports via an optional USB bracket. For purchasing the optional USB bracket, please contact the local dealer.

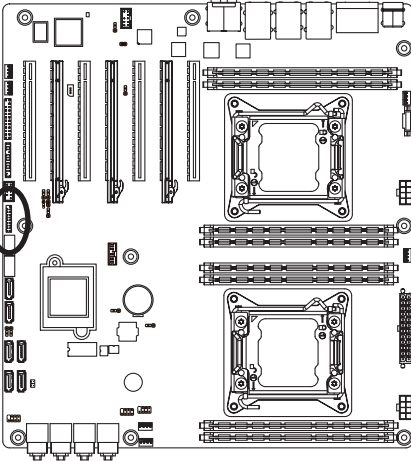

Pin No.	Definition
1	Power
2	IntA_P1_SSRX-
3	IntA_P1_SSRX+
4	GND
5	IntA_P1_SSTX-
6	IntA_P1_SSTX+
7	GND
8	IntA_P1_D-
9	IntA_P1_D+
10	NC
11	IntA_P2_D+
12	IntA_P2_D-
13	GND
14	IntA_P2_SSTX+
15	IntA_P2_SSTX-
16	GND
17	IntA_P2_SSRX+
18	IntA_P2_SSRX-
19	Power
20	No Pin

22) FRONT_USB (Front USB Headers)

The headers conform to USB 2.0/1.1 specification. Each USB header can provide two USB ports via an optional USB bracket. For purchasing the optional USB bracket, please contact the local dealer.

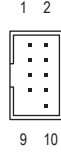
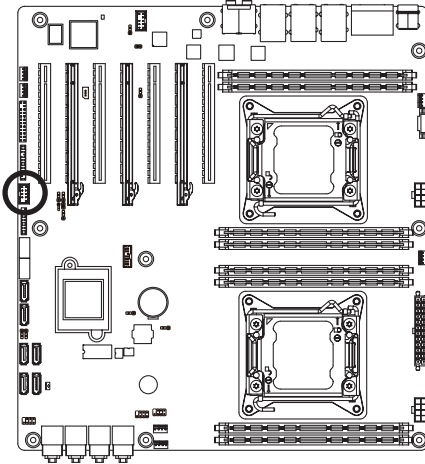

Pin No.	Definition
1	Power (5V)
2	Power (5V)
3	USB DX-
4	USB DY-
5	USB DX+
6	USB DY+
7	GND
8	GND
9	No Pin
10	NC

23/24) USB_A1/USB_A2 (USB 3.0 Type A Connectors)

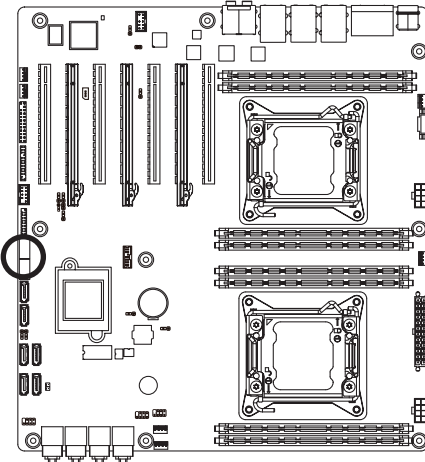

Pin No.	Definition
1	Power
2	USB D-
3	USB D+
4	GND
5	USB3 RXN-
6	USB3 RXP+
7	GND
8	USB3 TXN-
9	USB3 TXP+

25) FAUDIO_ACZ (Front Panel Audio Header)

The front panel audio header supports Intel High Definition audio (HD) and AC'97 audio. You may connect your chassis front panel audio module to this header. Make sure the wire assignments of the module connector match the pin assignments of the motherboard header. Incorrect connection between the module connector and the motherboard header will make the device unable to work or even damage it.

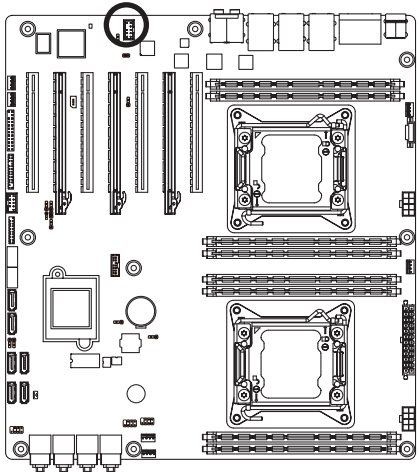

Pin No.	Definition
1	MIC2_L
2	GND
3	MIC2_R
4	FP_AUD_DET
5	LINE2_R
6	GND
7	FAUDIO_JD
8	No Pin
9	LINE2_L
10	GND



- The front panel audio header supports HD audio by default.
- Audio signals will be present on both of the front and back panel audio connections simultaneously.
- Some chassis provide a front panel audio module that has separated connectors on each wire instead of a single plug. For information about connecting the front panel audio module that has different wire assignments, please contact the chassis manufacturer.

26) F_PANEL1 (Front Panel Headers)

Connect the power switch, reset switch, speaker, chassis intrusion switch/sensor and system status indicator on the chassis to this header according to the pin assignments below. Note the positive and negative pins before connecting the cables.

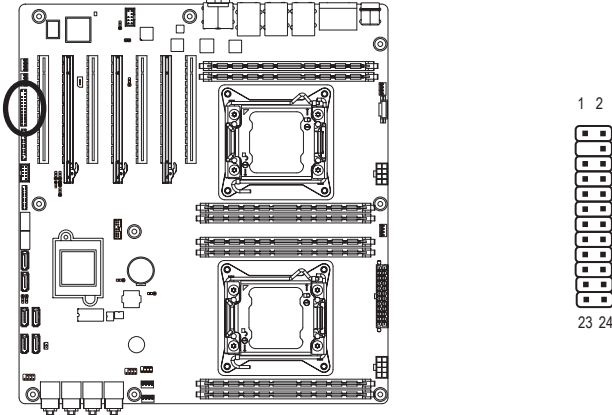

Pin No.	Signal Name	Definition
1	PWR_LED+	Power LED Signal anode (+)
2	5VSB	5V Standby Power
3	KEY	No Pin
4	ID_LED+	ID LED Signal anode (+)
5	PWR_LED-	Power LED Signal cathode(-)
6	ID_LED-	ID LED Signal cathode(-)
7	HDD_LED+	Hard Disk LED Signal anode (+)
8	SYS_STATUS+	System Front board LED Signal
9	HDD_LED-	Hard Disk LED Signal cathode(-)
10	SYS_STATUS-	System Status LED Signal cathode(-)
11	PWR_BTN	Power button
12	LAN1_LED+	LAN1 active LED Signal anode (+)
13	PWR_BTN (GND)	Ground
14	LAN1_LED-	LAN1 active LED Signal cathode(-)
15	RST_BTN	Reset button
16	SDA	SMBus Data Signal
17	RST_BTN (GND)	Ground
18	SCL	SMBus Clock Signal
19	ID_BTN	ID Switch button
20	CASE_OPEN	Chassis intrusion Signal
21	ID_SW (GND)	Ground
22	LAN2_LED+	LAN2 active LED Signal
23	NMI_BTN	NMI switch button
24	LAN2_LED-	LAN2 active LED Signal cathode(-)



The front panel design may differ by chassis. A front panel module mainly consists of power switch, reset switch, power LED, hard drive activity LED, speaker and etc. When connecting your chassis front panel module to this header, make sure the wire assignments and the pin assignments are matched correctly.

27) BP_1 (HDD Back Plane Board Headers)

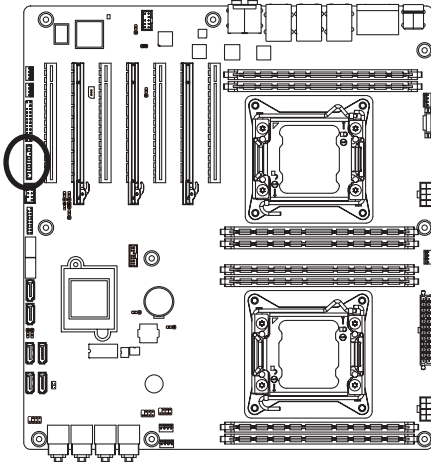

1 2
25 26

Pin No.	Definition
1	AST2300_SCCLK
2	FM_THROTTLE_AND_N
3	AST2300_SGLD
4	IQO_FAN_12v_GATE_N
5	AST2300_SGDOUT
6	GND
7	KEY
8	RresetL_BRB
9	GND
10	BP_ALED_N
11	BP_LED_G_N
12	GND
13	AST2300_SGDIN
14	ASSESS#_LED_BPB
15	GND
16	SMB_BPB1_DATA
17	GND
18	SMB_BPB1_CLK
19	P_3V3_AUX
20	BP_HDD_TYPE
21	P_3V3_AUX
22	FAN_TYPE
23	GND
24	KEY
25	BP_PRESENSE
26	GND

28) TPM_1 (TPM Module Connector)

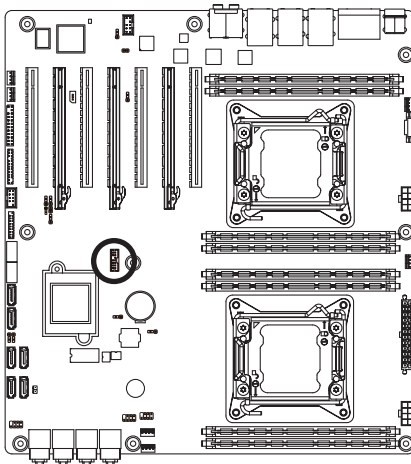

14 13
2 1

Pin No.	Definition
1	CLK_33M_TPM
2	P_3V3_AUX
3	LPC_RST_DEBUG
4	P3V3
5	LPC_LAD0
6	IRQ_SERIAL
7	LPC_LAD1
8	TPM_DET_N
9	LPC_LAD2
10	NC
11	LPC_LAD3
12	GND
13	LPC_FRAME_N
14	GND

29/30) SAS_SGPIO1/SAS_SGPIO2 (SAS SGPIO Headers)

SGPIO is stands for Serial General Purpose Input/Output which is a 4-signal (or 4-wire) bus used between a Host Bus Adapter (HBA) and a backplane. Out of the 4 signals, 3 are driven by the HBA and 1 is driven by the backplane. Typically, the HBA is a storage controller located inside a server, desktop, rack or workstation computer that interfaces with Hard disk drives (HDDs) to store and retrieve data.

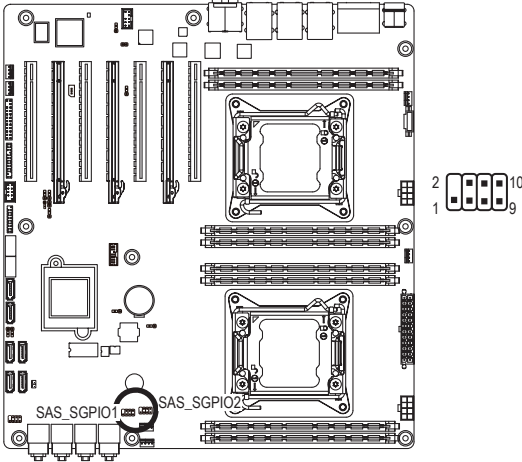

Pin No.	Definition
1	SGPIO_SATS_DATAIN
2	No Pin
3	SGPIO_SAS_DATAOUT
4	GND
5	GND
6	SGPIO_SAS_LOAD
7	NC
8	SGPIO_SAS_CLOCK

31) SATA_SGPIO1 (SATA SGPIO Headers)

SGPIO is stands for Serial General Purpose Input/Output which is a 4-signal (or 4-wire) bus used between a Host Bus Adapter (HBA) and a backplane. Out of the 4 signals, 3 are driven by the HBA and 1 is driven by the backplane. Typically, the HBA is a storage controller located inside a server, desktop, rack or workstation computer that interfaces with Hard disk drives (HDDs) to store and retrieve data.

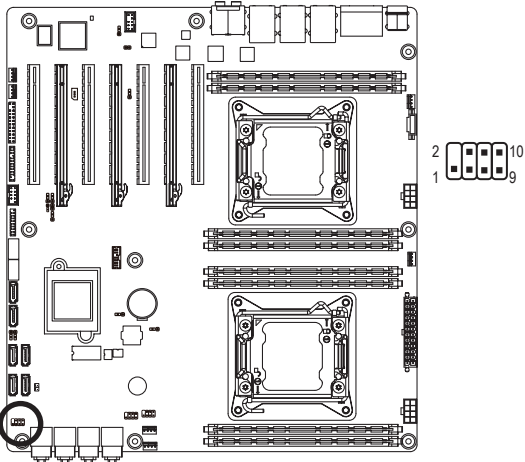

Pin No.	Definition
1	SGPIO_SATA_DATAIN
2	No Pin
3	SGPIO_SATA_DATAOUT
4	GND
5	GND
6	SGPIO_SATA_LOAD
7	NC
8	SGPIO_SATA_CLOCK

32) IPMB1 (IPMB Connector)

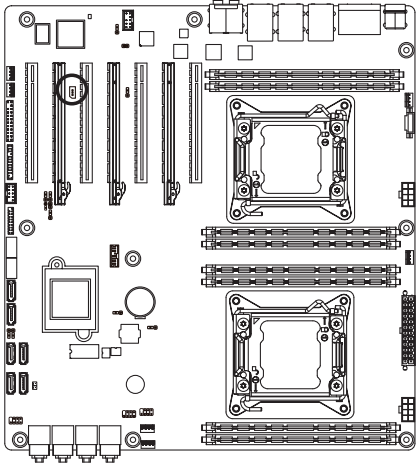

Pin No.	Definition
1	SCL
2	GND
3	SDA

33) SPDIF_OUT (S/PDIF Out Header)

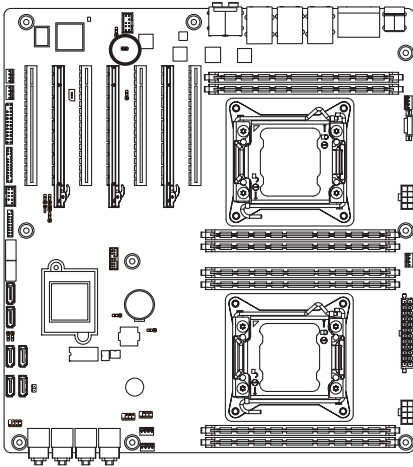

Pin No.	Definition
1	GND
2	SPDIF_OUT

34) BMC_LED1 (BMC Firmware Readiness LED)

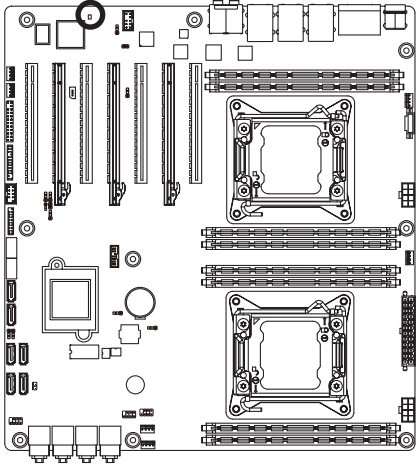

State	Description
On	BMC firmware is initial
Blinking	BMC firmware is ready
Off	System is powered off

35) RAIDKEY1 (LSI RAID Key Header)

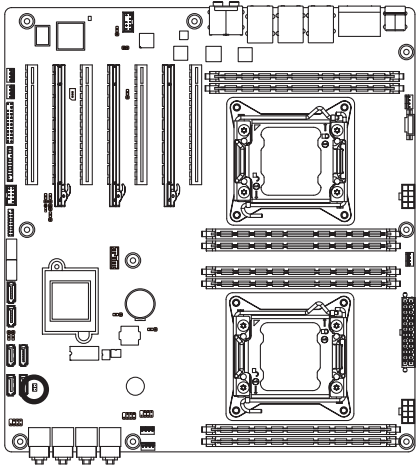

Pin No.	Definition
1	GPIO4
2	GND

36) BAT1 (Battery)

The battery provides power to keep the values (such as BIOS configurations, date, and time information) in the CMOS when the computer is turned off. Replace the battery when the battery voltage drops to a low level, or the CMOS values may not be accurate or may be lost.

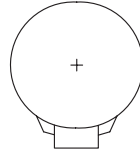
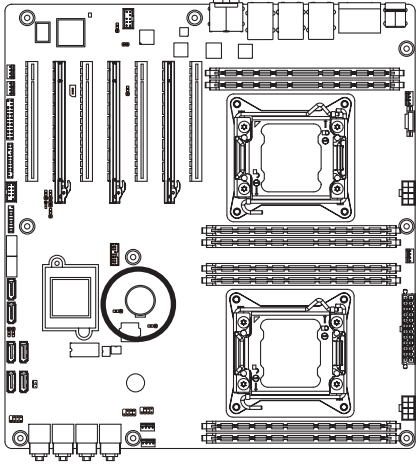

- Always turn off your computer and unplug the power cord before replacing the battery.
- Replace the battery with an equivalent one. Danger of explosion if the battery is replaced with an incorrect model.
- Contact the place of purchase or local dealer if you are not able to replace the battery by yourself or uncertain about the battery model.
- When installing the battery, note the orientation of the positive side (+) and the negative side (-) of the battery (the positive side should face up).
- Used batteries must be handled in accordance with local environmental regulations.

1-7 Jumper Settings

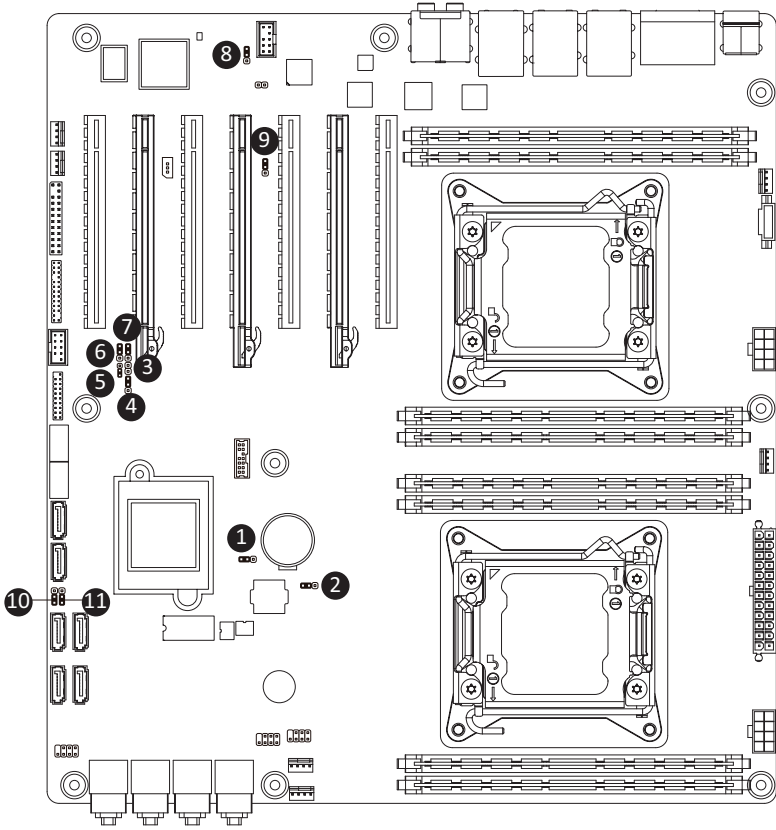



1)	CLR_CMOS1	7)	BIOS_RVCR1
2)	BIOS_WP1	8)	BMC_FRB1
3)	CHASSIS_OP	9)	PMBUS_SEL
4)	SSB_ME1	10)	SATA_DOM0
5)	S3_MASK	11)	SATA_DOM1
6)	PASWORD1		

1) CLR_CMOS1 (Clearing CMOS Jumper)

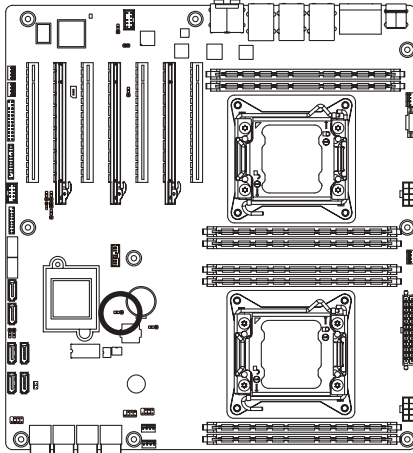
Use this jumper to clear the CMOS values (e.g. date information and BIOS configurations) and reset the CMOS values to factory defaults. To clear the CMOS values, place a jumper cap on the two pins to temporarily short the two pins or use a metal object like a screwdriver to touch the two pins for a few seconds.



1  1-2 Close: Normal operation (Default setting)

1  2-3 Close: Clear CMOS data.



- Always turn off your computer and unplug the power cord from the power outlet before clearing the CMOS values.
- After clearing the CMOS values and before turning on your computer, be sure to remove the jumper cap from the jumper. Failure to do so may cause damage to the motherboard.
- After system restart, go to BIOS Setup Exit menu and load factory defaults (select **Load Default Values**) or manually configure the BIOS settings (refer to Chapter 2, "BIOS Setup," for BIOS configurations).

2) BIOS_WP1 (BIOS Write Protect Jumper)

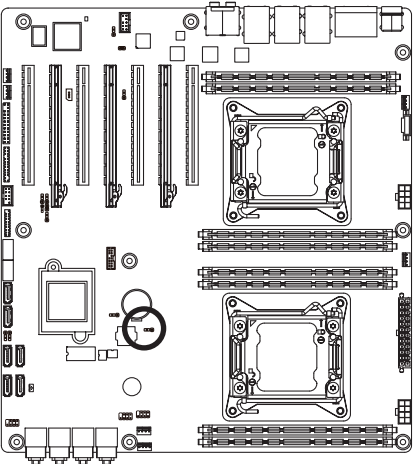



1  1-2 Close: Normal operation. (Default setting)

1  2-3 Close: Enable BIOS write protect function.

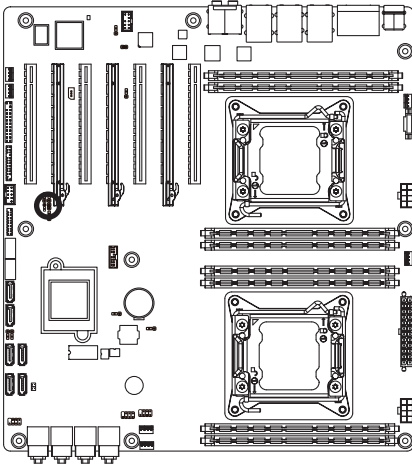

3) CASSIS_OP (Case open intrusion header)



-  Open: Normal operation.
-  Closed: Active chassis intrusion alert.

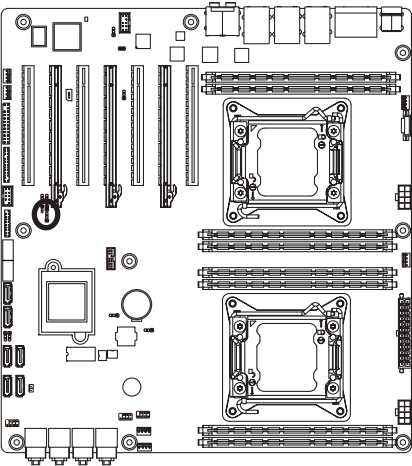

4) SSB_ME1 (ME enable/disable Jumper)



- 1  1-2 Close: Normal operation. (Default setting)
- 1  2-3 Close: Disable ME function.

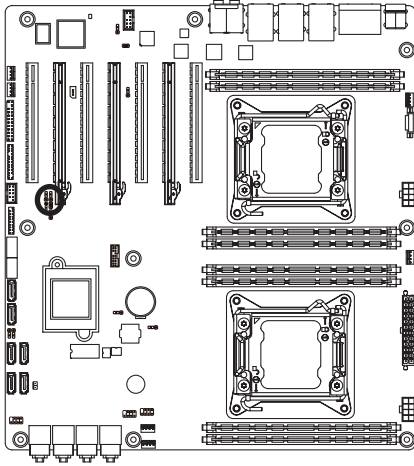

5) S3_MASK (S3 Power On Select Jumper)



- 1  1-2 Close: Stop an initial power on when BMC is not ready.
- 1  2-3 Close: Keep initial power on. (Default setting)

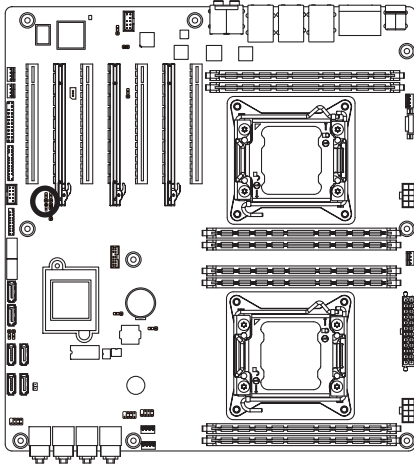

6) PASSWORD1 (Clearing Supervisor Password Jumper)



- 1  1-2 Close: Normal operation. (Default setting)
- 1  2-3 Close: Clear supervisor password.

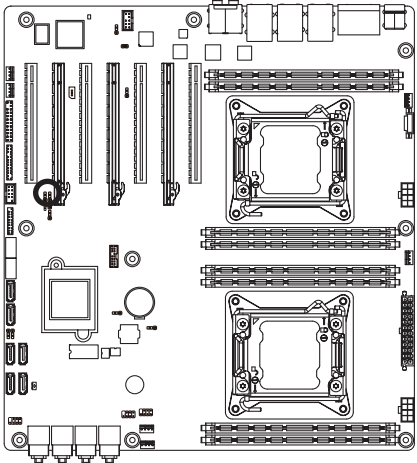

7) BIOS_RVCR1 (BIOS Recovery Jumper)



- 1  1-2 Close: Normal operation. (Default setting)
- 1  2-3 Close: BIOS recovery mode.

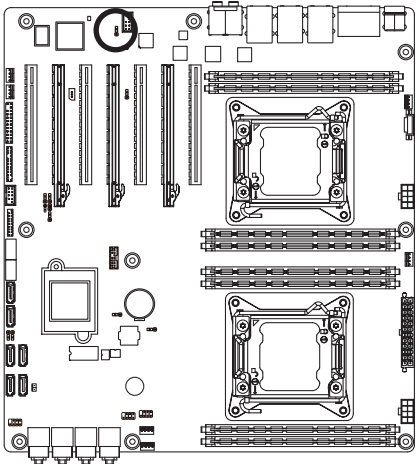

8) BMC_FRB1 (Force to Stop FRB1 Timer Jumper)

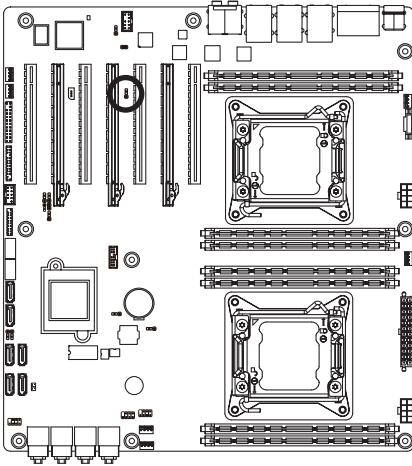

- 1  1-2 Close: Normal operation. (Default setting)
- 1  2-3 Close: Force to Stop FRB1 Timer.

9) PMBUS_SEL (PMBus Power Select Jumper)





- 1  1-2 Close: PMBus connects to PCH.
- 1  2-3 Close: PMBus connects to BMC.
(Default setting)

10/11) SATA_DOM0/SATA_DOM1 (SATA DOM Jumpers)

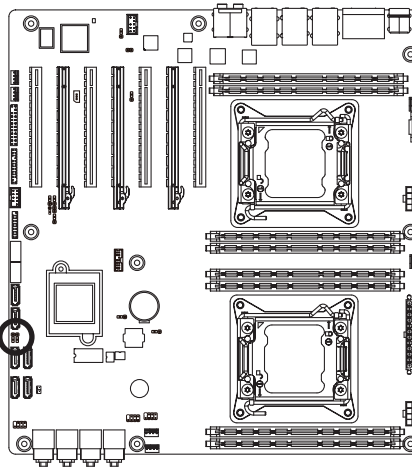

CAUTION! If a SATA type hard drive is connected to the motherboard, please ensure the jumper is closed and set to **2-3 pins** (Normal mode), in order to reduce any risk of hard disk damage.



- 1  1-2 Close: Enable SATA port 0/1 DOM support.
- 1  2-3 Close: Normal mode. (Default setting)

Chapter 2 BIOS Setup

BIOS (Basic Input and Output System) records hardware parameters of the system in the EFI on the motherboard. Its major functions include conducting the Power-On Self-Test (POST) during system startup, saving system parameters and loading operating system, etc. BIOS includes a BIOS Setup program that allows the user to modify basic system configuration settings or to activate certain system features. When the power is turned off, the battery on the motherboard supplies the necessary power to the CMOS to keep the configuration values in the CMOS.

To access the BIOS Setup program, press the <F2> key during the POST when the power is turned on.



- BIOS flashing is potentially risky, if you do not encounter problems of using the current BIOS version, it is recommended that you don't flash the BIOS. To flash the BIOS, do it with caution. Inadequate BIOS flashing may result in system malfunction.
- It is recommended that you not alter the default settings (unless you need to) to prevent system instability or other unexpected results. Inadequately altering the settings may result in system's failure to boot. If this occurs, try to clear the CMOS values and reset the board to default values. (Refer to the "Load Optimized Defaults" section in this chapter or introductions of the battery/clearing CMOS jumper in Chapter 1 for how to clear the CMOS values.)

BIOS Setup Program Function Keys

<<-><->>	Move the selection bar to select the screen
<↑><↓>	Move the selection bar to select an item
<Enter>	Execute command or enter the submenu
<Esc>	Main Menu: Exit the BIOS Setup program Submenus: Exit current submenu
<F1>	Show descriptions of general help
<F3>	Restore the previous BIOS settings for the current submenus
<F9>	Load the Optimized BIOS default settings for the current submenus
<F10>	Save all the changes and exit the BIOS Setup program

■ **Main**

This setup page includes all the items in standard compatible BIOS.

■ **Advanced**

This setup page includes all the items of AMI BIOS special enhanced features.

(ex: Auto detect fan and temperature status, automatically configure hard disk parameters.)

■ **Chipset**

This setup page includes all the submenu options for configuring the function of North Bridge and South Bridge.

(ex: Auto detect fan and temperature status, automatically configure hard disk parameters.)

■ **Security**

Change, set, or disable supervisor and user password. Configuration supervisor password allows you to restrict access to the system and BIOS Setup.

A supervisor password allows you to make changes in BIOS Setup.

A user password only allows you to view the BIOS settings but not to make changes.

■ **Server Management**

Server additional features enabled/disabled setup menus.

■ **Boot Options**

This setup page provides items for configuration of boot sequence.

■ **Boot Manager**

This setup page provides configuration of boot up devices.

■ **Exit**

Save all the changes made in the BIOS Setup program to the CMOS and exit BIOS Setup. (Pressing <F10> can also carry out this task.)

Abandon all changes and the previous settings remain in effect. Pressing <Y> to the confirmation message will exit BIOS Setup. (Pressing <Esc> can also carry out this task.)

2-1 The Main Menu

Once you enter the BIOS Setup program, the Main Menu (as shown below) appears on the screen. Use arrow keys to move among the items and press <Enter> to accept or enter other sub-menu.

Main Menu Help

The on-screen description of a highlighted setup option is displayed on the bottom line of the Main Menu.

Submenu Help

While in a submenu, press <F1> to display a help screen (General Help) of function keys available for the menu. Press <Esc> to exit the help screen. Help for each item is in the Item Help block on the right side of the submenu.



- When the system is not stable as usual, select the **Load Default Values** item to set your system to its defaults.
- The BIOS Setup menus described in this chapter are for reference only and may differ by BIOS version.

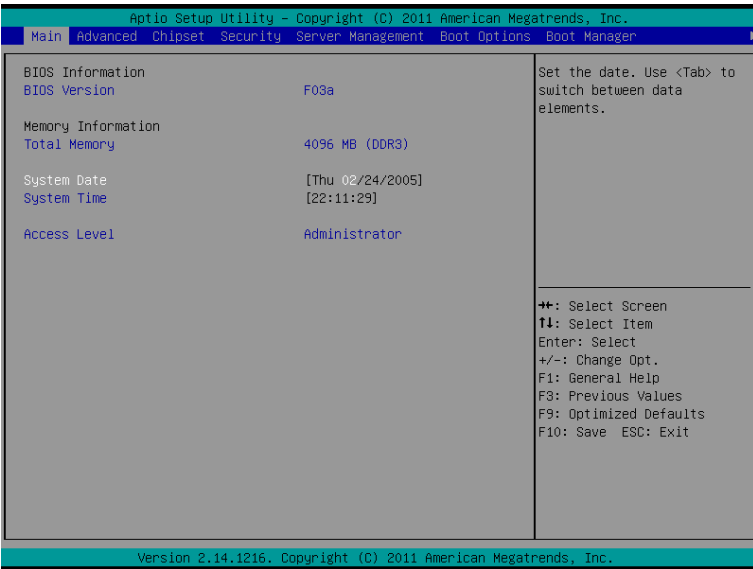

☞ **BIOS Information**

☞ **BIOS Version**

Display version number of the BIOS setup utility.

☞ **Memory Information**

☞ **Total Memory**

Determines how much total memory is present during the POST.

☞ **System Date**

Set the date following the weekday-month-day- year format.

☞ **System Time**

Set the system time following the hour-minute- second format.

☞ **Access Level**

Display the current accessing level information.

2-2 Advanced Menu

The Advanced menu display submenu options for configuring the function of various hardware components. Select a submenu item, then press Enter to access the related submenu screen.

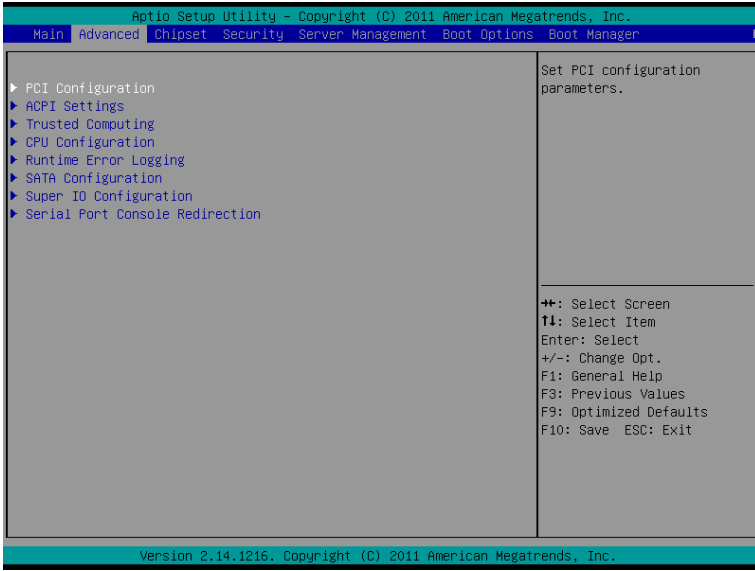

2-2-1 PCI Configuration

Aptio Setup Utility - Copyright (C) 2011 American Megatrends, Inc.			
Advanced			
PCI Express Slot #1 Option ROM	[Enabled]	Enable/Disable PCI/PCI-Express slot #1 Option ROM.	
PCI Express Slot #2 Option ROM	[Enabled]		
PCI Express Slot #3 Option ROM	[Enabled]		
PCI Express Slot #4 Option ROM	[Enabled]		
PCI Express Slot #5 Option ROM	[Enabled]		
PCI Express Slot #6 Option ROM	[Enabled]		
PCI Express Slot #7 Option ROM	[Enabled]		
Onboard LSI Option ROM	[Enabled]		
Onboard LAN #1 Controller	[Enabled]		
Onboard LAN #2 Controller	[Enabled]		
Onboard LAN #1 Option ROM	[Enabled]		
Onboard LAN #2 Option ROM	[Enabled]		
PERR# Generation	[Disabled]		++: Select Screen !!: Select Item Enter: Select +/-: Change Opt. F1: General Help F3: Previous Values F9: Optimized Defaults F10: Save ESC: Exit
SERR# Generation	[Disabled]		
Maximum Payload	[Auto]		
Version 2.14.1216. Copyright (C) 2011 American Megatrends, Inc.			

☞ PCI Express Slot 1/2/3/4/5/6/7 I/O ROM

When enabled, This setting will initialize the device expansion ROM for the related PCI-E slot.

Options available: Enabled/Disabled. Default setting is **Enabled**.

☞ Onboard LSI Option ROM

Enable/Disable Onboard LSI Option ROM.

Options available: Enabled/Disabled. Default setting is **Enabled**.

☞ Onboard LAN1/2 Controller

Enable/Disable Onboard LAN1/LAN2 controller .

Options available: Enabled/Disabled. Default setting is **Enabled**.

☞ LAN1/2 Option ROM

Enable/Disable onboard LAN1/LAN2 device and initialize device expansion ROM.

Options available: Enabled/Disabled. Default setting is **Enabled**.

☞ PERR Generation

When this item is set to enabled, PCI bus parity error (PERR) is generated and is routed to NMI.

Options available: Enabled/Disabled. Default setting is **Disabled**.

☞ SERR Generation

When this item is set to enabled, PCI bus system error (SERR) is generated and is routed to NMI.

Options available: Enabled/Disabled. Default setting is **Disabled**.

☞ Maximum Payload

Set maximum payload for PCI Express Device or allow system BIOS to select the value.

Options available: Auto/128 Bytes/256 Bytes/512 Bytes/1024 Bytes/2048 Bytes/4096 Bytes.

Default setting is **Auto**.

2-2-2 ACPI Settings

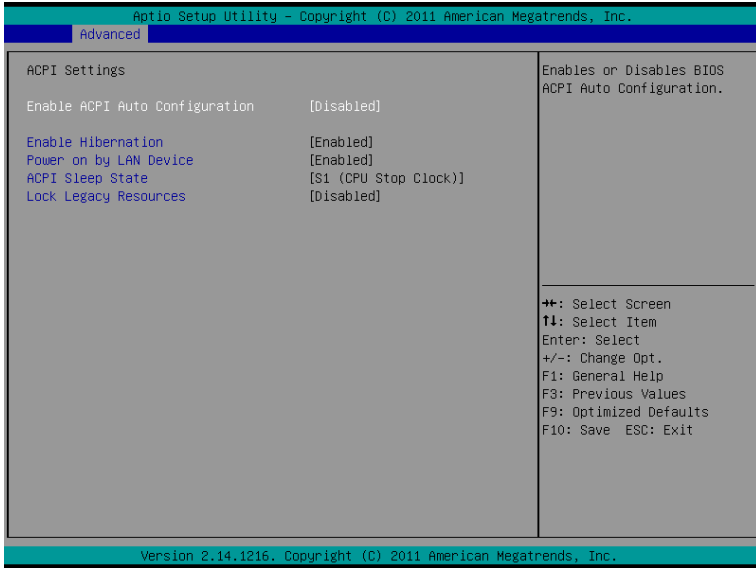

☞ Enable ACPI Auto Configuration

Enable/Disable BIOS ACPI configuration features.

Options available: Enabled/Disabled. Default setting is **Disabled**.

☞ Enable Hibernation

Enable/Disable system ability to hibernate (OS/S4 Sleep State). This option may be not effective with some operating system.

Options available: Enabled/Disabled. Default setting is **Enabled**.

☞ Power On by LAN Device

Enable/Disable Power on by LAN Device feature.

Options available: Enabled/Disabled. Default setting is **Enabled**.

☞ ACPI Sleep State

Select the highest ACPI sleep state the system will enter, when the suspend button is pressed.

Options available: Suspend Disabled/S1 only (CPU Stop Clock)/S3 only (Suspend to RAM)/ Both S1 and S3 available for OS to choose from. Default setting is **S1 only (CPU Stop Clock)**.

☞ Lock Legacy Resource

Enable/Disable Lock of Legacy Resources feature.

Options available: Enabled/Disabled. Default setting is **Disabled**.

2-2-3 Trusted Computing (Optional)

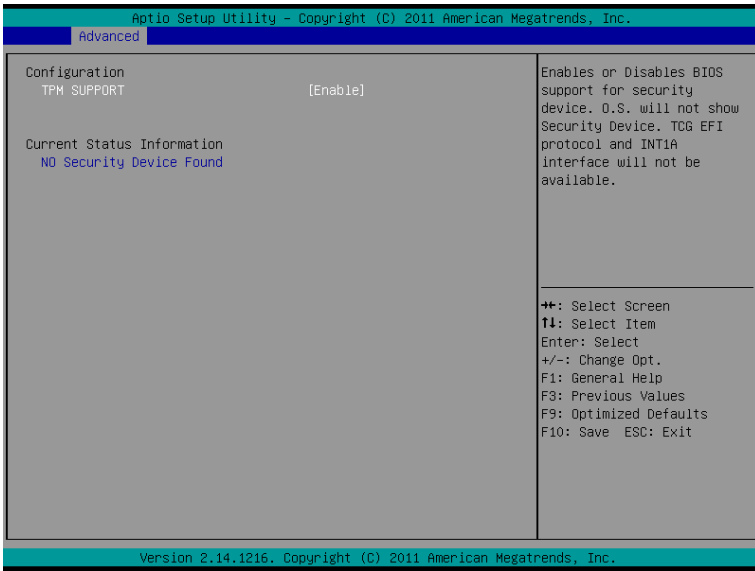

☞ TPM Support

Select Enabled to activate TPM support feature.

Options available: Enabled/Disabled. Default setting is **Enabled**.

☞ Current Status Information

Display current TPM status information.

2-2-4 CPU Configuration

Aptio Setup Utility - Copyright (C) 2011 American Megatrends, Inc.

Advanced

<p>CPU Configuration</p> <ul style="list-style-type: none"> ▶ Socket 0 CPU Information ▶ Socket 1 CPU Information <p>CPU Speed 64-bit Supported</p> <p>Active Processor Cores [All] Limit CPUID Maximum [Disabled] Execute Disable Bit [Enabled] Energy Performance [Performance] Intel Virtualization Technology [Enabled]</p> <ul style="list-style-type: none"> ▶ CPU Power Management Configuration 	<p>Socket specific CPU Information</p> <hr/> <p>↔: Select Screen ↑: Select Item Enter: Select +/-: Change Opt. F1: General Help F3: Previous Values F9: Optimized Defaults F10: Save ESC: Exit</p>
--	--

Version 2.14.1216. Copyright (C) 2011 American Megatrends, Inc.

Aptio Setup Utility - Copyright (C) 2011 American Megatrends, Inc.

Advanced

<p>Socket 0 CPU Information</p> <p>Intel(R) Xeon(R) CPU E5-2603 0 @ 1.80GHz CPU Signature 205d6 Microcode Patch 619 Max CPU Speed 1800 MHz Min CPU Speed 1200 MHz Processor Cores 4 Intel HT Technology Not Supported Intel VT-x Technology Supported</p> <p>L1 Data Cache 32 kB x 4 L1 Code Cache 32 kB x 4 L2 Cache 256 kB x 4 L3 Cache 10240 kB</p>	<p>↔: Select Screen ↑: Select Item Enter: Select +/-: Change Opt. F1: General Help F3: Previous Values F9: Optimized Defaults F10: Save ESC: Exit</p>
--	---

Version 2.14.1216. Copyright (C) 2011 American Megatrends, Inc.

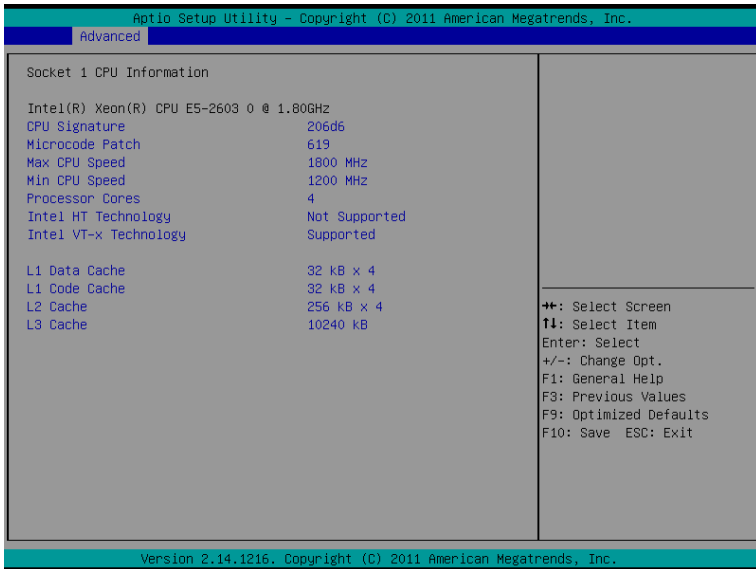

☞ **Socket 0/1 CPU Information**

☞ **CPU Signature**

Displays the processor ID information.

☞ **Microcode Patch**

Display Microcode patch information.

☞ **Max CPU Speed**

Display the maximum processor speed.

☞ **Min CPU Speed**

Display the minimum processor speed.

☞ **Processor Cores**

Display the information of the processor core.

☞ **Intel HT Technology**

Display Intel Hyper Threading Technology function support information.

☞ **Intel VT-x Technology**

Display Intel Virtualization Technology function support information.

☞ **Cache Information**

☞ **L1 Data Cache**

Display the information of L1 Data Cache.

☞ **L1 Code Cache**

Display the information of L1 Code Cache.

☞ **L2 Cache**

Display the total L2 cache memory of the installed processor in megabytes. If the installed processor is multi-core, it is displayed as number of cores x L2 cache per core.

☞ **L3 Cache**

Display the total L2 cache memory of the installed processor in megabytes. This item appears when the installed processor supports L3 .

☞ **CPU Speed**

Display the current installed CPU speed.

☞ **64-bit**

Display the supported information of installed CPU.

☞ **Active Processor Cores** (Note)

Allows you to determine whether to enable all CPU cores.

Options available: All/1/2/3. Default setting is **All**.

☞ **Limit CPUID Maximum**

When enabled, the processor will limit the maximum CPUID input values to 03h when queried, even if the processor supports a higher CPUID input value.

When disabled, the processor will return the actual maximum CPUID input value of the processor when queried.

Options available: Enabled/Disabled. Default setting is **Disabled**.

☞ **Execute Disable Bit**

When enabled, the processor prevents the execution of code in data-only memory pages. This provides some protection against buffer overflow attacks.

When disabled, the processor will not restrict code execution in any memory area. This makes the processor more vulnerable to buffer overflow attacks.

Options available: Enabled/Disabled. Default setting is **Enabled**.

☞ **Energy Performance**

Energy Performance Bias is Intel CPU function.

The larger value in MSR_ENERGY_PERFORMANCE_BIAS register,

CPU will save more power but lose more performance.

Note: This register will be changed by OS too if OS support it like Windows 2008 or newer Linux.

Options available:

Performance : Write value 0 into MSR_ENERGY_PERFORMANCE_BIAS

Balanced Performance: Write value 7 into MSR_ENERGY_PERFORMANCE_BIAS

Balanced Energy: Write value 11 into MSR_ENERGY_PERFORMANCE_BIAS

Energy Efficient: Write value 15 into MSR_ENERGY_PERFORMANCE_BIAS

Default setting is **Performance**.

☞ **Intel Virtualization Technology**

Select whether to enable the Intel Virtualization Technology function. VT allows a single platform to run multiple operating systems in independent partitions.

Options available: Enabled/Disabled. Default setting is **Enabled**.

(Note) This item is present only if you install a CPU that supports this feature. For more information about Intel CPUs' unique features, please visit Intel's website.

2-2-4-1 CPU Power Management Configuration

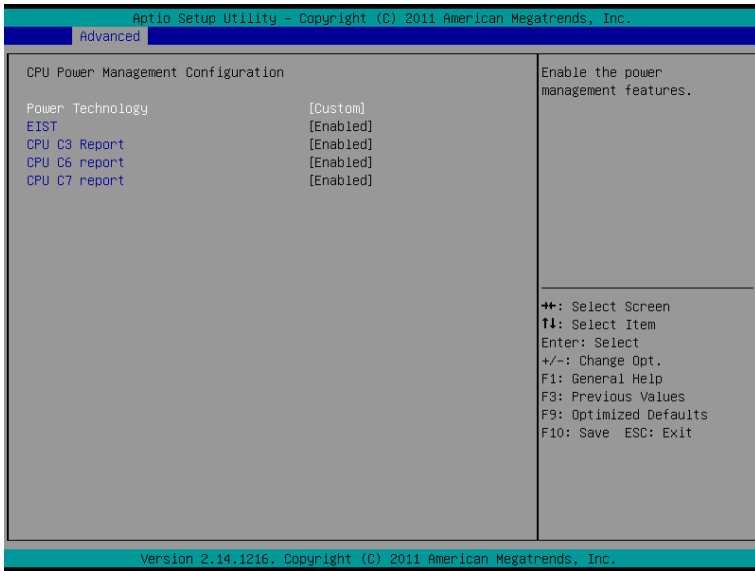

☞ CPU Power Management Configuration

☞ Power Technology

Configure the power management features.

Options available: Disable/Energy Efficient/Custom. Default setting is **Custom**.

☞ EIST (Enhanced Intel SpeedStep Technology)

Conventional Intel SpeedStep Technology switches both voltage and frequency in tandem between high and low levels in response to processor load.

Options available: Enabled/Disabled. Default setting is **Enabled**.

☞ CPU C3/C6 Report ^(Note)

Allows you to determine whether to let the CPU enter C3/C6 mode in system halt state. When enabled, the CPU core frequency and voltage will be reduced during system halt state to decrease power consumption. The C3/C6 state is a more enhanced power-saving state than C1.

Options available: Enabled/Disabled. Default setting is **Enabled**.

☞ CPU C7 Report ^(Note)

Allows you to enable or disable the CPU C7 (ACPI C3) report.

Options available: Enabled/Disabled. Default setting is **Enabled**.

(Note) This item is present only if you install a CPU that supports this feature. For more information about Intel CPUs' unique features, please visit Intel's website.

2-2-5 Runtime Error Logging

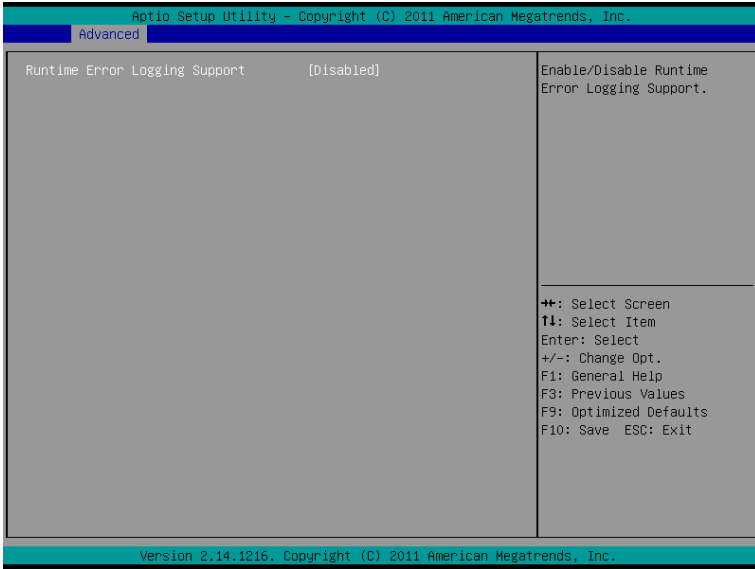

☞ Runtime Error Logging

Enable/Disable Runtime error logging support.

Options available: Enabled/Disabled. Default setting is **Disabled**.

2-2-6 SATA Configuration

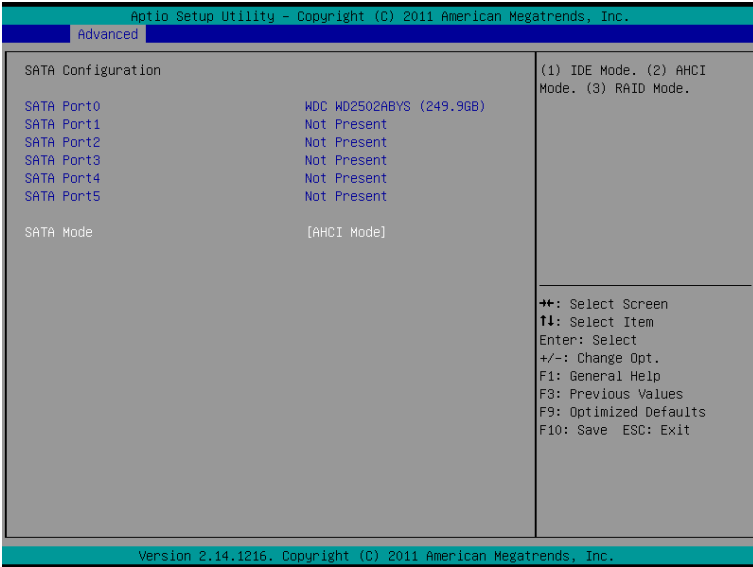

☞ **SATA Port 0/1/2/3/4/5** (Note)

Displays the installed HDD devices information.

☞ **SATA Mode**

Select the on chip SATA type.

RAID Mode: When set to RAID, the SATA controller enables both its RAID and AHCI functions. You will be allowed access to the RAID setup utility at boot time.

AHCI Mode: When set to AHCI, the SATA controller enables its AHCI functionality. Then the RAID function is disabled and cannot access the RAID setup utility at boot time.

Options available: RAID/AHCI/Disabled. Default setting is **AHCI Mode**.

(Note) This item will not appear when the SATA mode is set to RAID mode.

2-2-7 Super IO Configuration

Aptio Setup Utility - Copyright (C) 2011 American Megatrends, Inc.	
Advanced	
Super IO Configuration Super IO Chip IT8728 ▶ Serial Port 1 Configuration	Set Parameters of Serial Port 1 (COM1) ++: Select Screen ↑↓: Select Item Enter: Select +/-: Change Opt. F1: General Help F3: Previous Values F9: Optimized Defaults F10: Save ESC: Exit
Version 2.14.1216. Copyright (C) 2011 American Megatrends, Inc.	

Aptio Setup Utility - Copyright (C) 2011 American Megatrends, Inc.	
Advanced	
Serial Port 1 Configuration Serial Port [Enabled] Device Settings ID=3F8h; IRQ=4; Change Settings [Auto] Device Mode [Standard Serial Port Mode]	Enable or Disable Serial Port (COM) ++: Select Screen ↑↓: Select Item Enter: Select +/-: Change Opt. F1: General Help F3: Previous Values F9: Optimized Defaults F10: Save ESC: Exit
Version 2.14.1216. Copyright (C) 2011 American Megatrends, Inc.	

☞ **Super IO Configuration**

☞ **Serial Port 1 Configuration**

☞ **Serial Port**

When enabled allows you to configure the serial port settings. When set to Disabled, displays no configuration for the serial port.

Options available: Enabled/Disabled. Default setting is **Enabled**.

☞ **Device Settings**

Displays the Serial Port 1 base I/O address and IRQ.

☞ **Change Settings**

Change Serial Port 1 device settings. When set to Auto allows the server's BIOS or OS to select a configuration.

Options available: Auto/I/O=3F8; IRQ=4/I/O=3F8h; IRQ=3,4,5,6,7,10,11,12/

IO=2F8h; IRQ=3,4,5,6,7,10,11,12 /IO=3E8h; IRQ=3,4,5,6,7,10,11,12/IO=2E8h; IRQ=3,4,5,6,7,10,11,12.

☞ **Device Mode**

Change the Serial Port mode.

Options available: Standard Serial Port Mode (Normal Mode)/IrDA 1.0 (HP SIR) Mode (High Speed)/ASKIRfdgdg Mode.

2-2-8 Serial Port Console Redirection

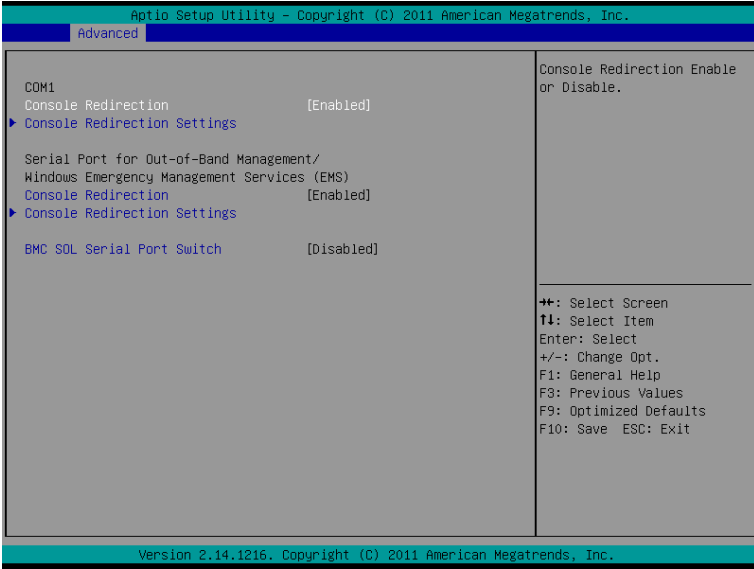

☞ Console Redirection ^(Note)

Select whether to enable console redirection for specified device. Console redirection enables users to manage the system from a remote location.

Options available: Enabled/Disabled. Default setting is **Disabled**.

☞ COM1 Console Redirection Settings

Press [Enter] to enter advanced menu for console redirection settings.

☞ Terminal Type

Select a terminal type to be used for console redirection.

Options available: VT100/VT100+/ANSI /VT-UTF8.

☞ Bits per second

Select the baud rate for console redirection.

Options available: 9600/19200/57600/115200.

☞ Data Bits

Select the data bits for console redirection.

Options available: 7/8.

☞ Parity

A parity bit can be sent with the data bits to detect some transmission errors.

Even: parity bit is 0 if the num of 1's in the data bits is even.

Odd: parity bit is 0 if num of 1's the data bits is odd.

Mark: parity bit is always 1. Space: Parity bit is always 0.

Mark and Space Parity do not allow for error detection.

Options available: None/Even/Odd/Mark/Space.

(Note) Advanced items prompt when this item is defined.

☞ **Stop Bits**

Stop bits indicate the end of a serial data packet. (A start bit indicates the beginning). The standard setting is 1 stop bit. Communication with slow devices may require more than 1 stop bit.

Options available: 1/2.

☞ **Flow Control**

Flow control can prevent data loss from buffer overflow. When sending data, if the receiving buffers are full, a 'stop' signal can be sent to stop the data flow. Once the buffers are empty, a 'start' signal can be sent to re-start the flow. Hardware flow control uses two wires to send start/stop signals.

Options available: None/Hardware RTS/CTS.

☞ **VT-UTF8 Combo Key Support**

Enable/Disable VT-UTF8 Combo Key Support.

Options available: Enabled/Disabled. Default setting is **Enabled**.

☞ **Serial Port for Out-of-Band Management/Windows Emergency Service (EMS)**

☞ **Console Redirection** ^(Note)

Select whether to enable console redirection for specified device. Console redirection enables users to manage the system from a remote location.

Options available: Enabled/Disabled. Default setting is **Disabled**.

☞ **Console Redirection Settings**

Press [Enter] to enter advanced menu for console redirection settings.

☞ **Out-of-Band Mgmt Port**

Microsoft Windows Emergency Management Service (EMS) allows for remote management of a Windows Server OS through a serial port.

Options available: COM1

☞ **Terminal Type**

Select a terminal type to be used for console redirection.

Options available: VT100/VT100+/ANSI /VT-UTF8.

☞ **Bits per second**

Select the baud rate for console redirection.

Options available: 9600/19200/57600/115200.

☞ **Data Bits**

Select the data bits for console redirection.

Options available: 7/8.

☞ **Parity**

A parity bit can be sent with the data bits to detect some transmission errors.

Even: parity bit is 0 if the num of 1's in the data bits is even.

Odd: parity bit is 0 if num of 1's the data bits is odd.

Mark: parity bit is always 1. Space: Parity bit is always 0.

Mark and Space Parity do not allow for error detection.

Options available: None/Even/Odd/Mark/Space.

☞ **Stop Bits**

Stop bits indicate the end of a serial data packet. (A start bit indicates the beginning). The standard setting is 1 stop bit. Communication with slow devices may require more than 1 stop bit.

Options available: 1/2.

(Note) Advanced items prompt when this item is defined.

☞ **BMC SOL Serial Port Switch**

Enabled: COM1 Switch to AST2300 SOL UART.

Disabled: COM1 Switch to IT8728 SOL UART1.

Options available: Enabled/Disabled. Default setting is **Disabled**.

2-3 Chipset Menu

The Chipset menu display submenu options for configuring the function of North Bridge and South Bridge. Select a submenu item, then press Enter to access the related submenu screen.

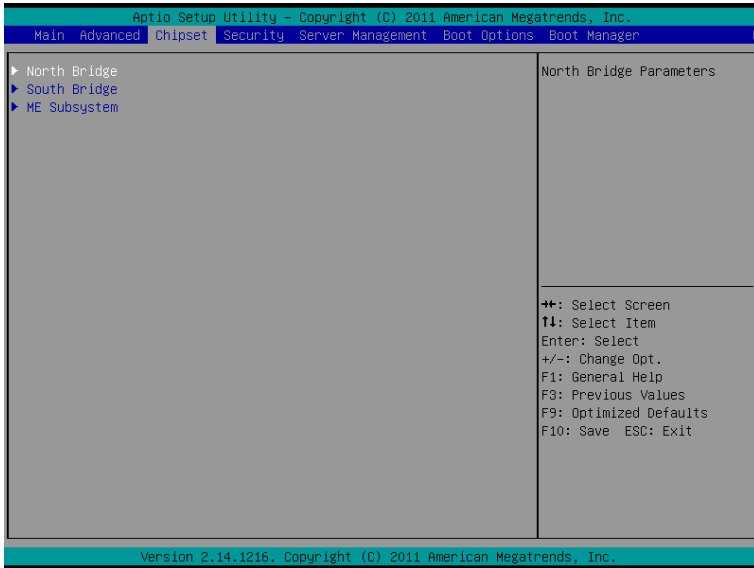

2-3-1 North Bridge Configuration

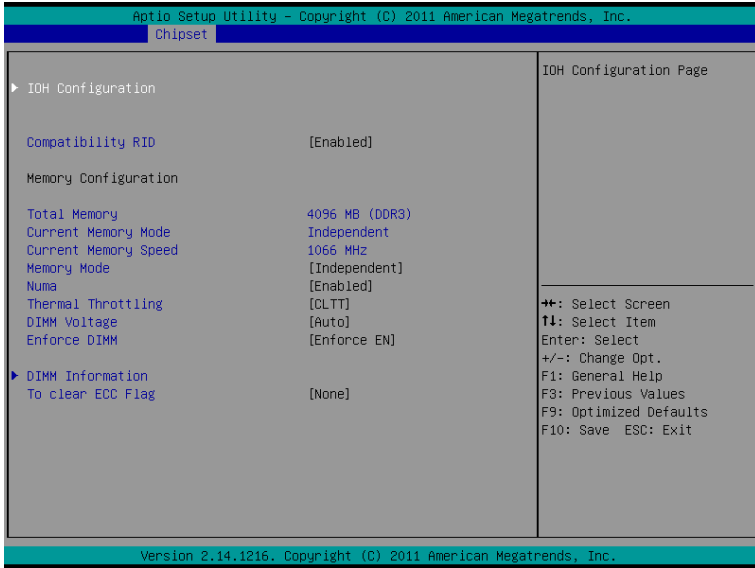

☞ Compatibility RID

Enable/Disable Compatibility RID function.

Options available: Enabled/Disabled. Default setting is **Enabled**.

☞ Memory Configuration

☞ Total Memory

Determines how much total memory is present during the POST.

☞ Current Memory Mode

Displays the current memory mode. Memory mode can be determined in **Memory Mode** item.

☞ Current Memory Speed

Displays the current memory speed.

☞ Memory Mode

Determine the memory mode.

When set to Independent mode, all DIMMs are available to the operation system.

When set to Mirroring mode, the motherboard maintains two identical (redundant) copies of all data in memory.

When set to Lockstep mode, the motherboard uses two areas of memory to run the same set of operations in parallel.

When set to Sparing mode, a preset threshold of correctable errors is used to trigger fail-over.

The spare memory is put online and used as active memory in place of the failed memory.

Options available: Independent /Mirroring/ Lockstep/Sparing.

☞ **Numa**

Enable/Disable Non Uniform Memory Access (NUMA) function.

Options available: Enabled/Disabled. Default setting is **Enabled**.

☞ **Thermal Thortting**

Configure the Thermal Thortting.

Options available: CLTT/OLTT/Disabled. Default setting is **Disabled**.

☞ **DIMM Voltage**

Configure the DIMM voltage.

Options available: Auto/ Force 1.5v/Force 1.35v. Default setting is **Auto**.

☞ **Enforce DIMM**

To enforce POR function. When disabled, the system will enforce 1600MHz LRDIMM.

Options available: Enforce EN/Stretch EN/Enforce DIS. Default setting is **Enforce EN**.

☞ **To clear ECC Flag**

To clear ECC flag function.

Options available: None. Default setting is **None**.

2-3-1-1 IOH Configuration

Aptio Setup Utility - Copyright (C) 2011 American Megatrends, Inc.		
Chipset		
<p>▶ Intel(R) VT for Directed I/O Configuration</p> <p>VGA Priority [Offboard]</p> <p>Gen3 Equalization WA's [Disabled]</p> <p>MMCFG BASE [0x80000000]</p> <p>Io Ratio Skt0 6</p> <p>Io Ratio Skt1 2</p> <p>Mmio Ratio Skt0 6</p> <p>Mmio Ratio Skt1 2</p> <p>IOH 0 PCIe port Bifurcation Control</p> <p>Patsburg UpLink PCIe Speed [GEN2]</p> <p>LSI2008 PCIe Speed [GEN2]</p> <p>PCIe Slot3 Speed [GEN3]</p> <p>PCIe Slot1 Speed [GEN3]</p> <p>IOH 1 PCIe port Bifurcation Control</p> <p>PCIe Slot7 Speed [GEN3]</p> <p>PCIe Slot5 Speed [GEN3]</p>	<p>Intel(R) VT for Directed I/O Configuration</p>	<p>++: Select Screen</p> <p>↑↓: Select Item</p> <p>Enter: Select</p> <p>+/-: Change Opt.</p> <p>F1: General Help</p> <p>F3: Previous Values</p> <p>F9: Optimized Defaults</p> <p>F10: Save ESC: Exit</p>
Version 2.14.1216. Copyright (C) 2011 American Megatrends, Inc.		

Aptio Setup Utility - Copyright (C) 2011 American Megatrends, Inc.		
Chipset		
<p>Intel(R) VT-d [Enabled]</p> <p>ATS Support [Disabled]</p>	<p>Enable/Disable Intel(R) Virtualization Technology for Directed I/O.</p>	<p>++: Select Screen</p> <p>↑↓: Select Item</p> <p>Enter: Select</p> <p>+/-: Change Opt.</p> <p>F1: General Help</p> <p>F3: Previous Values</p> <p>F9: Optimized Defaults</p> <p>F10: Save ESC: Exit</p>
Version 2.14.1216. Copyright (C) 2011 American Megatrends, Inc.		

☞ **IOH Configuration**

☞ **Intel(R) VT for Directed I/O Configuration**

☞ **VGA Priority**

Define the display device priority.

☞ **Gen3 Equalization WA's**

Enable/Disable the support for Gen3 Equalization Workaround.
Options available: Enabled/Disabled. Default setting is **Disabled**.

☞ **MMCFG BASE (Base address of the Memory Mapped Configuration Space)**

Configure the MMCFG BASE.
Options available: 0x80000000/0x40000000. Default setting is **0x80000000**.

☞ **Io Ratio Skt0**

Press the numeric keys to configure the desired values.

☞ **Io Ratio Skt1**

Press the numeric keys to configure the desired values.

☞ **Mmio Ratio Skt0**

Press the numeric keys to configure the desired values.

☞ **Mmio Ratio Skt1**

Press the numeric keys to configure the desired values.

☞ **IOH 0 PCIe port Bifurcation Control**

☞ **Patsburg Uplink PCIE Speed**

Select Target Link Speed.
Options available: GEN1/GEN2/GEN3. Default setting is **GEN2**.

☞ **Patsburg Uplink PCIE Speed**

Select Target Link Speed.
Options available: GEN1/GEN2/GEN3. Default setting is **GEN2**.

☞ **LSI2008 PCIE Speed**

Select Target Link Speed.
Options available: GEN1/GEN2/GEN3. Default setting is **GEN2**.

☞ **PCIE Slot 3 Speed**

Select Target Link Speed for PCIE slot 3.
Options available: GEN1/GEN2/GEN3. Default setting is **GEN3**.

☞ **PCIE Slot 1 Speed**

Select Target Link Speed for PCIE slot 1.
Options available: GEN1/GEN2/GEN3. Default setting is **GEN3**.

☞ **IOH 1 PCIe port Bifurcation Control**

☞ **PCIE Slot 7 Speed**

Select Target Link Speed for PCIE slot 7.
Options available: GEN1/GEN2/GEN3. Default setting is **GEN3**.

☞ **PCIE Slot 5 Speed**

Select Target Link Speed for PCIE slot 5.
Options available: GEN1/GEN2/GEN3. Default setting is **GEN3**.

☞ **Intel(R) VT-d**

Enable/Disable Intel VT-d Technology function.

Options available: Enabled/Disabled. Default setting is **Enabled**.

☞ **ATS Support**

Enable/Disable VT-d Engine Aggress Translation Service (ATS) support.

Options available: Enabled/Disabled. Default setting is **Disabled**.

2-3-1-2 DIMM Information

Aptio Setup Utility - Copyright (C) 2011 American Megatrends, Inc.

Chipset

CPU Socket 0 DIMM Information	
DDR3_P0_A0	Present 4096 MB (DDR3)
DDR3_P0_B0	Not Present
DDR3_P0_C0	Not Present
DDR3_P0_D0	Not Present
CPU Socket 1 DIMM Information	
DDR3_P1_E0	Not Present
DDR3_P1_F0	Not Present
DDR3_P1_G0	Not Present
DDR3_P1_H0	Not Present

++: Select Screen
↑: Select Item
Enter: Select
+/-: Change Opt.
F1: General Help
F3: Previous Values
F9: Optimized Defaults
F10: Save ESC: Exit

Version 2.14.1216, Copyright (C) 2011 American Megatrends, Inc.

☞ DIMM Information:

☞ DIMM Group: CPU Socket 0/1 DIMM Information

CPU Socket 0:

DDR3_P0_A0/DDR3_P0_B0/DDR3_P0_C0/DDR3_P0_D0 Status

The size of memory installed on each of the DDR3 slots.

CPU Socket 1:

DDR3_P0_E0/DDR3_P0_F0/DDR3_P0_G0/DDR3_P0_H0

Status

The size of memory installed on each of the DDR3 slots.

2-3-2 South Bridge Configuration

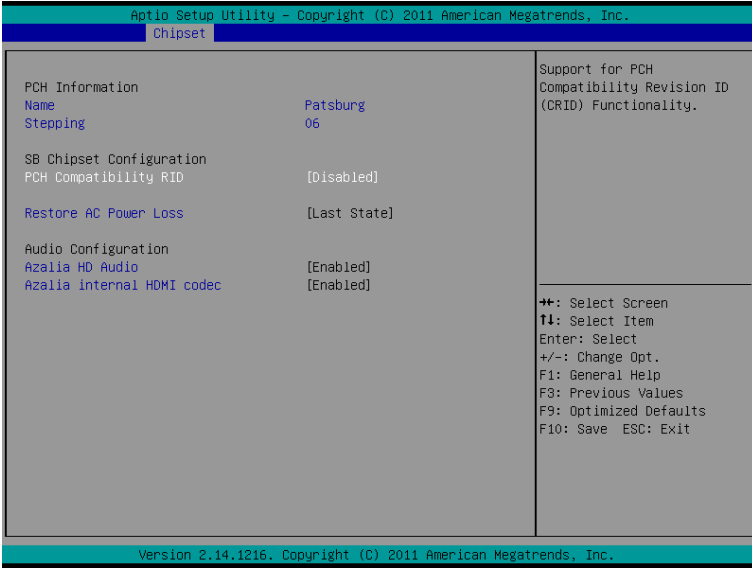

☞ PCH Information:

☞ Name/Stepping Information

Displays the name and stepping information of the south bridge.

☞ SB Chipset Configuration

☞ PCH Compatibility RID

Enable/Disable PCH Compatibility RID support.

Options available: Enabled/Disabled. Default setting is **Disabled**.

☞ Restore on AC Power Loss ^(Note)

Defines the power state to resume to after a system shutdown that is due to an interruption in AC power. When set to Last State, the system will return to the active power state prior to shutdown. When set to Stay Off, the system remains off after power shutdown.

Options available: Last State/Stay Off/Power On. The default setting depends on the BMC setting.

☞ Audio Configuration

☞ Azalia HD Audio

Enable/Disable onboard Audio controller.

Options available: Enabled/Disabled. Default setting is **Enabled**.

☞ Azalia internal HDMI codec

Enable/Disable internal HDMI codec.

Options available: Enabled/Disabled. Default setting is **Enabled**.

(Note) When the power policy is controlled by BMC, please wait for 15-20 seconds for BMC to save the last power state.

2-3-3 ME Subsystem

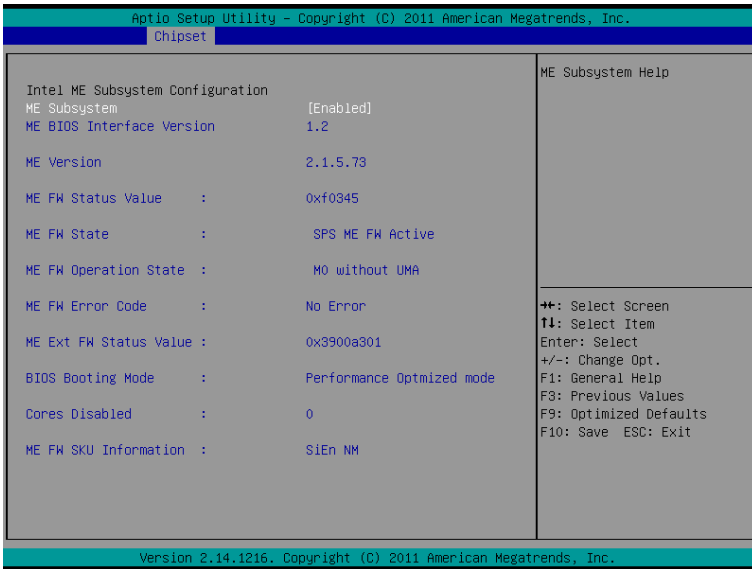

☞ Intel ME Subsystem Configuration

☞ ME Subsystem

Enable/Disable ME Subsystem function.

Options available: Enabled/Disabled. Default setting is **Enabled**.

2-4 Security Menu

The Security menu allows you to safeguard and protect the system from unauthorized use by setting up access passwords.

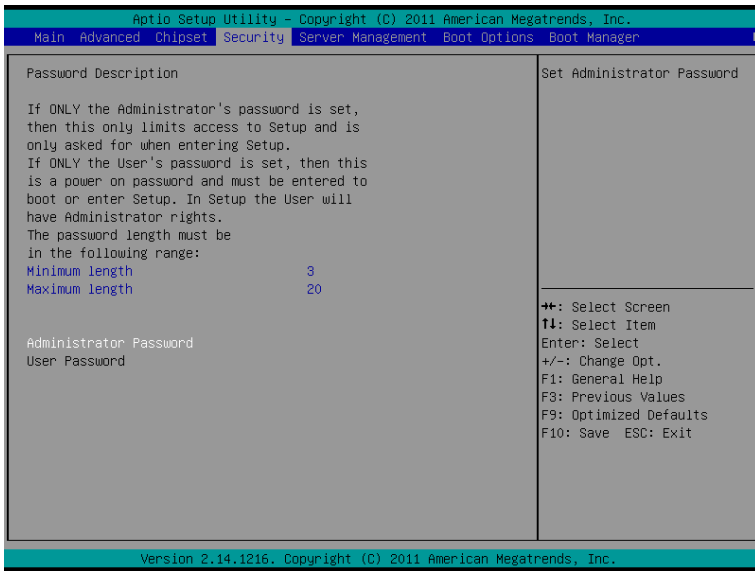

There are two types of passwords that you can set:

- **Administrator Password**
Entering this password will allow the user to access and change all settings in the Setup Utility.
- **User Password**
Entering this password will restrict a user's access to the Setup menus. To enable or disable this field, a Administrator Password must first be set. A user can only access and modify the System Time, System Date, and Set User Password fields.

⌂ **Administrator Password**

Press Enter to configure the Administrator password.

⌂ **User Password**

Press Enter to configure the user password.

2-5 Server Management Menu

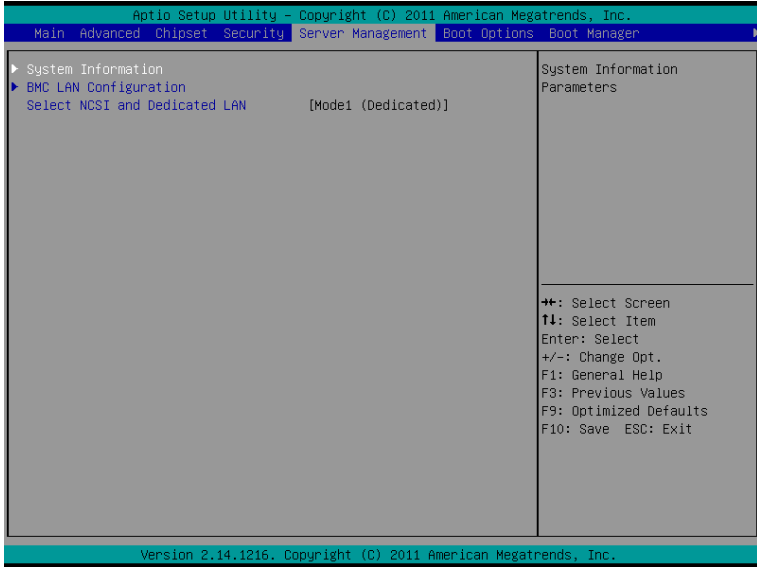

System Information

Displays basic system ID information, as well as BIOS version. Press Enter to access the related submenu.

BMC LAN Configuration

BMC LAN Configuration. Press Enter to access the related submenu.

Select NCSI and Dedicated LAN

Switch NCSI and dedicated LAN and send KCS command.

Options available: Mode2(NCSI)/ Mode1 (Dedicated). Default setting is **Mode1 (Dedicated)**.

2-5-1 System Information

The System Management submenu is a simple display page for basic system information, as well as product BMC version information, SDR version information, and FRU version information. Items on this window are non-configurable.

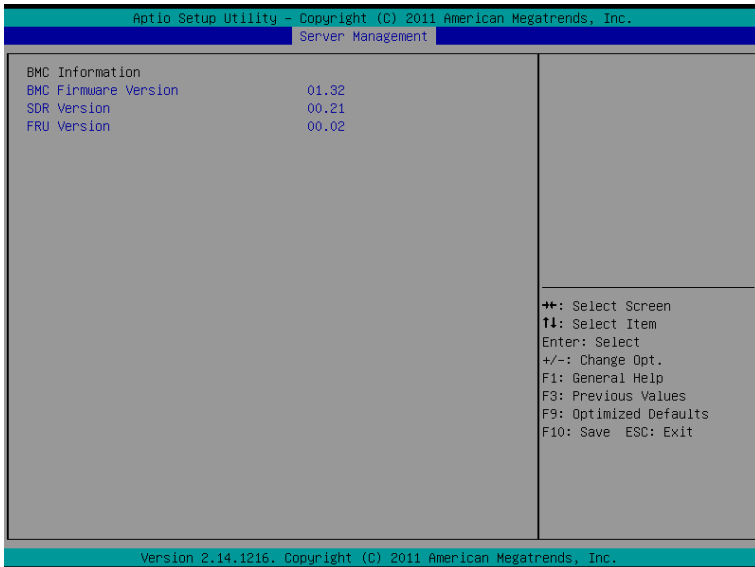

2-5-2 BMC LAN Configuration

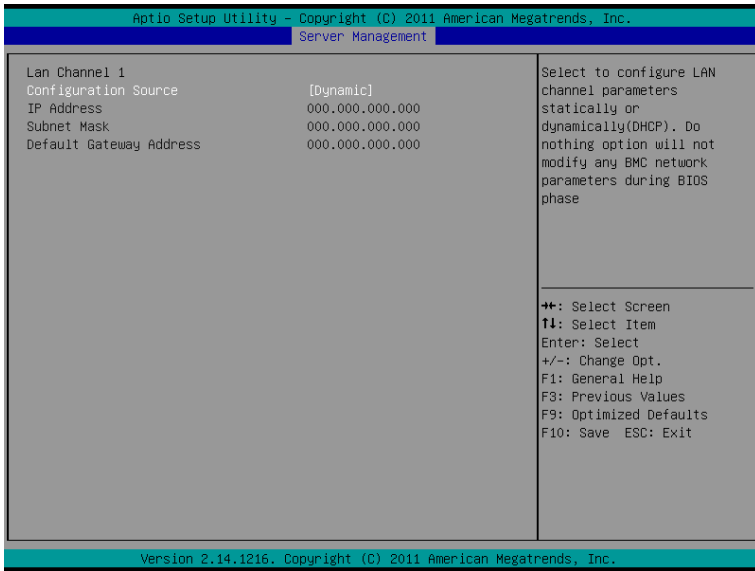

☞ Lan Channel 1

☞ Configuration Source

Select to configure LAN channel parameters statically or dynamically (DHCP). Do nothing option will not modify any BMC network parameters during BIOS phase.

Options available: Static/Dynamic/Do Nothing. Default setting is **Dynamic**.

☞ IP Address^(Note)

Display configured IP Address information.

☞ Subnet Mask^(Note)

Display configured Subnet Mask information.

☞ Default Gateway Address^(Note)

Display Default Gateway Address information.

(Note) The item is configureable when **Configuration Source** is set to Static.

2-6 Boot Option Menu

The Boot menu allows you to set the drive priority during system boot-up. BIOS setup will display an error message if the legacy drive(s) specified is not bootable.

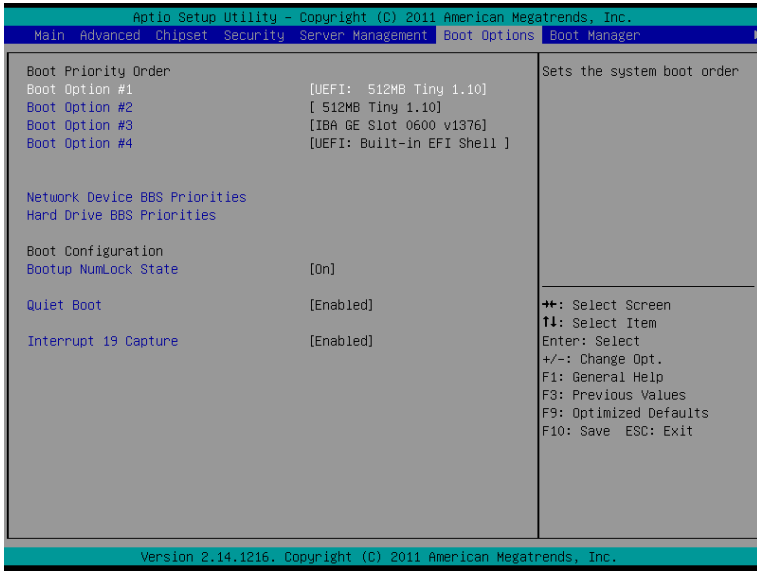

☞ Boot Priority Order

☞ Boot Option #1/#2/#3/#4

Press [Enter] to configure the boot priority.

By default, the server searches for boot devices in the following sequence:

1. UEFI device.
2. Hard drive.
3. Network device.
4. USB device.

☞ Network Device BBS Priorities

Press Enter to configure the boot priority.

☞ Hard Drive BBS Priorities

Press [Enter] for advanced configuration.

☞ Bootup Configuration

☞ Bootup NumLock State

Enable or Disable Bootup NumLock function.

Options available: On/Off. Default setting is **On**.

☞ **Quiet Boot**

Enables or disables showing the logo during POST.

Options available: Enabled/Disabled. Default setting is **Enabled**.

☞ **Interrupt 19 Capture**

Interrupt 19 is the software interrupt that handles the boot disk function. When enabled, this BIOS feature allows the ROM BIOS of those host adaptors to "capture" Interrupt 19 during the boot process so that drives attached to these adaptors can function as bootable disks.

Options available: Enabled/Disabled. Default setting is **Enabled**.

2-7 Boot Manager

The Boot manager menu allows you to specify the boot-up drive. BIOS setup will display an error message if the legacy drive(s) specified is not bootable.

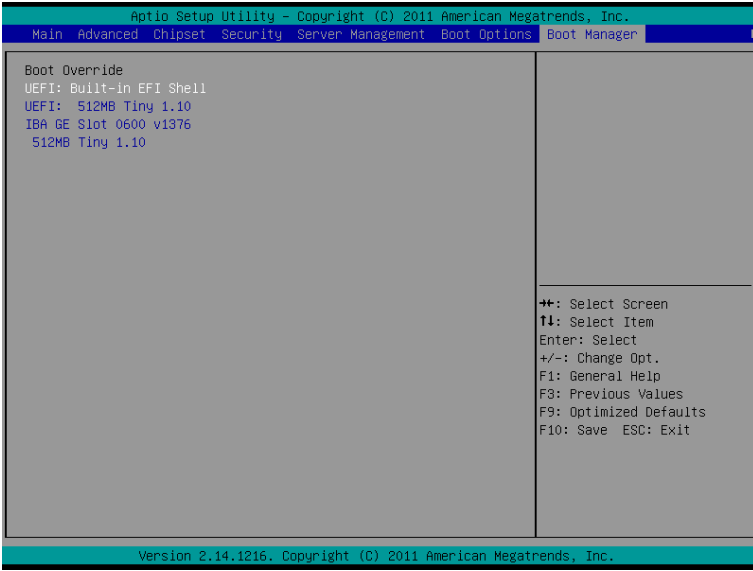

⤷ Boot Override

⤷ UEFI: Built-in EFI Shell

Press Enter to configure the device as the boot-up drive.

2-8 Exit Menu

The Exit menu displays the various options to quit from the BIOS setup. Highlight any of the exit options then press **Enter**.

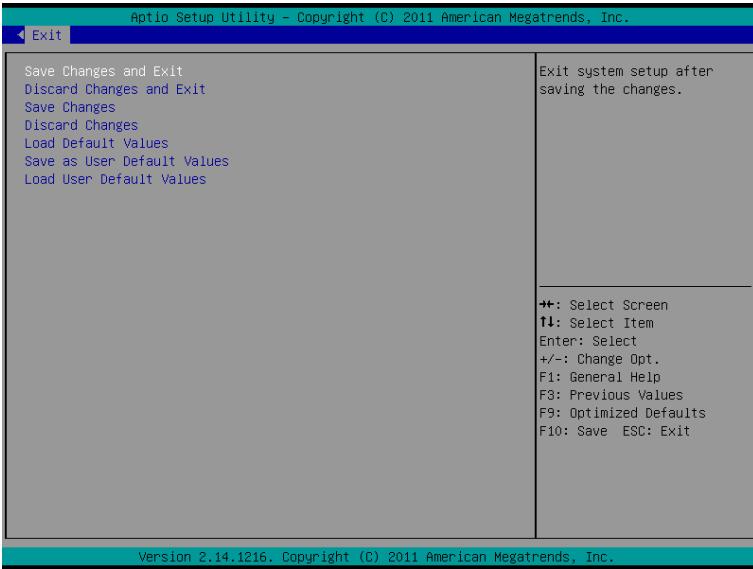

☞ **Save Changes and Exit**

Saves changes made and close the BIOS setup.

Options available: Yes/No.

☞ **Discard Changes and Exit**

Discards changes made and close the BIOS setup.

Options available: Yes/No.

☞ **Save Changes**

Saves changes made in the BIOS setup.

Options available: Yes/No.

☞ **Discard Changes**

Discards all changes made in the BIOS setup.

Options available: Yes/No.

☞ **Load Default Values**

Loads the default settings for all BIOS setup parameters. Setup Defaults are quite demanding in terms of resources consumption. If you are using low-speed memory chips or other kinds of low-performance components and you choose to load these settings, the system might not function properly.

Options available: Yes/No.

☞ **Save as User Default Values**

Saves as user default and close the BIOS setup.

Options available: Yes/No.

☞ **Load User Default Values**

Loads the user default settings for all BIOS setup parameters.

Options available: Yes/No.

Chapter 3 Appendix

3-1 Regulatory Statements

Regulatory Notices

This document must not be copied without our written permission, and the contents there of must not be imparted to a third party nor be used for any unauthorized purpose. Contravention will be prosecuted. We believe that the information contained herein was accurate in all respects at the time of printing. GIGABYTE cannot, however, assume any responsibility for errors or omissions in this text. Also note that the information in this document is subject to change without notice and should not be construed as a commitment by GIGABYTE.

Our Commitment to Preserving the Environment

In addition to high-efficiency performance, all GIGABYTE motherboards fulfill European Union regulations for RoHS (Restriction of Certain Hazardous Substances in Electrical and Electronic Equipment) and WEEE (Waste Electrical and Electronic Equipment) environmental directives, as well as most major worldwide safety requirements. To prevent releases of harmful substances into the environment and to maximize the use of our natural resources, GIGABYTE provides the following information on how you can responsibly recycle or reuse most of the materials in your "end of life" product.

Restriction of Hazardous Substances (RoHS) Directive Statement

GIGABYTE products have not intended to add and safe from hazardous substances (Cd, Pb, Hg, Cr+6, PBDE and PBB). The parts and components have been carefully selected to meet RoHS requirement. Moreover, we at GIGABYTE are continuing our efforts to develop products that do not use internationally banned toxic chemicals.

Waste Electrical & Electronic Equipment (WEEE) Directive Statement

GIGABYTE will fulfill the national laws as interpreted from the 2002/96/EC WEEE (Waste Electrical and Electronic Equipment) directive. The WEEE Directive specifies the treatment, collection, recycling and disposal of electric and electronic devices and their components. Under the Directive, used equipment must be marked, collected separately, and disposed of properly.

WEEE Symbol Statement



The symbol shown below is on the product or on its packaging, which indicates that this product must not be disposed of with other waste. Instead, the device should be taken to the waste collection centers for activation of the treatment, collection, recycling and disposal procedure.

The separate collection and recycling of your waste equipment at the time of disposal will help to conserve natural resources and ensure that it is recycled in a manner that protects human health and the environment. For more information about where you can drop off your waste equipment for recycling, please contact your local government office, your household waste disposal service or where you purchased the product for details of environmentally safe recycling.

- ◆ When your electrical or electronic equipment is no longer useful to you, "take it back" to your local or regional waste collection administration for recycling.
- ◆ If you need further assistance in recycling, reusing in your "end of life" product, you may contact us at the Customer Care number listed in your product's user's manual and we will be glad to help you with your effort.

Finally, we suggest that you practice other environmentally friendly actions by understanding and using the energy-saving features of this product (where applicable), recycling the inner and outer packaging (including shipping containers) this product was delivered in, and by disposing of or recycling used batteries properly. With your help, we can reduce the amount of natural resources needed to produce electrical and electronic equipment, minimize the use of landfills for the disposal of "end of life" products, and generally improve our quality of life by ensuring that potentially hazardous substances are not released into the environment and are disposed of properly.