

System Installation Guide

GS-SR101T

## **1U Rack Mount Server**

# **SYSTEM INSTALLATION GUIDE**

# INDEX

<b><u>1.</u></b>	<b><u>INTRODUCTION</u></b>	<b><u>1-1</u></b>
1.1.	PREFACE	1-1
1.2.	FEATURES	1-1
<b><u>2.</u></b>	<b><u>HARDWARE INVENTORY</u></b>	<b><u>2-1</u></b>
<b><u>3.</u></b>	<b><u>SYSTEM INSTALLATION</u></b>	<b><u>3-1</u></b>
3.1.	CHASSIS COVER REMOVAL	3-1
3.2.	PROCESSOR INSTALLATION	3-2
3.3.	FAN+HEATSINK INSTALLATION	3-4
3.4.	SYSTEM RAM INSTALLATION	3-6
3.5.	INSTALLING HANDLE	3-7
3.6.	REINSTALL TOP COVER	3-8
3.7.	HARD DISK DRIVE INSTALLATION	3-9
3.8.	FRONT SIDE	3-14
3.9.	LED INDICATORS	3-14
3.10.	BACK SIDE	3-15
3.11.	CONNECTOR ICONS	3-16

# 1. INTRODUCTION

## 1.1. Preface

Using this manual will help you get the most from your Rack Mount Server. Keeping the manual with your Rack Mount Server to refer when you want information and help.

In order to get the optimal usage out of your Rack Mount Server and you should remember the following:

- Read through all the instruction for your Rack Mount Server .
- Keep the area free of static electricity and magnetic fields. These can damage the Server .
- When cleaning the server or its components, apply the proper cleaning solution or sprays only on the cloth ,not to the server or its components .

## 1.2. Features

Our Rack Mount Server use 1U Chassis and support the following features:

### ***Processor Support***

- Dual Socket 370 for Intel FC-PGA Coppermine and Tualatin processor Up to 1 GHz and above
- Optimal CPU Keep Out Zone for Type C Heat-sink
- 100/133MHz FSB
- AUTO detect CPU voltage

### ***BIOS***

- AMI BIOS on 4M bit flash ROM

- Auto configure IDE HDD type
- Multiple boot options
- User setting for hardware monitoring
- DMI 2.0 compliant

### **Chipset**

- VIA Apollo Pro Family AGP set  
( VT82C694T ,VT82C686B ) Chipset
- ATI Rage XL 2X VGA Chip with 8MB Video Memory
- PROMISE PDC20265R with RAID 0 or 1 support
- Dual Intel 82559 LAN chip

### **Memory Support**

- Four 25 degree angled 168 Pin DIMM sockets for SDRAM modules
- Supports up to 2GB PC-100/PC-133 Error Checking and Correction (ECC) either un-buffered or registered memory and VCM SDRAM
- Supports only 3.3V SDRAM DIMM

### **Storage Controller**

- Max 4 IDE ATA channels ( 2 x ATA-66 and 2 x ATA-100 for IDE RAID 0 or 1 )
- Support front-accessible 2 hot-swap drives featuring IDE ATA-100 transferring rate
- 44MB Floppy Disk Drive ( Slim type )
- High Speed IDE CD-ROM Drive ( Slim type)

### **Networking**

- On board dual LAN, Ethernet 10/100 WOL (Wake

On LAN)

- Adaptive fail over feature
- Load balance feature

#### ***I/O Expansion Slot***

- PCI raisers , 1 slot ,support 33MHz & PCI 2.2 compliant

#### ***Build-in I/O ports***

- 1 x PS/2 Keyboard port
- 1 x PS/2 Mouse port
- 1 x COM port
- 1 x VGA port
- 1 x LPT port
- 2 x RJ-45 ports
- 2 x USB ports

#### ***Power***

- Total output power 250 W
- Input : Rating switch full range 90V~250V 47~63 Hz

#### ***Operating Temperature***

- 5 to 40 degree C

#### ***Thermal Solution***

- Special-designed Heat-sink and hi-efficiency chassis fans for dual 1 GHz plus processor thermal solution

***Other Features***

- Support Wake On LAN ( WOL )
- Support External Modem Ring On
- Optional DOC solution for embedded Internet/Networking Applications

***O/S Support***

- Windows NT ,Windows 2000 ,Linux ( RED HAT 7.0 , Netware 5.0

***Chassis Dimensions***

- Height 44.45 mm ( 1.75 In. )
- Width 482.6 mm ( 19.0 In. )
- Depth 609.6 mm ( 24.0 In. )
- System weight 11.8 Kg ( 26 lbs )

## 2. Hardware Inventory

When you unpack your GS-SR101 Rack Mount Server, Check that all the items that you ordered are present in good condition. Review the inventory checklist below to be sure that the components and optional components that you ordered are included. If anything is miss or damage, contact your retailer as soon as possible.

- Chassis
- Power Supply ( Installed )
- Motherboard GA-6VTXDR ( Installed )
- Manuals (M/B user's Manual & System Installation)
- Hard Disk Drive Tray x 2
- Flat Screw # 6-32 \* 5L x 12 ( For HDDs)
- Fan + Heat sink x 2
- Case Handle x 2
- Flat Screw M4\*10L x 4 ( For Handle )
- Support CD x1
- Support Floppy Disk x 2





### 3. System Installation

Note: Please remove the protection plastic cover from top and bottom side first. If not, the system heat could not spread from top and bottom side.

#### 3.1. Chassis Cover Removal

Use screwdriver to remove the two screws on the chassis top cover . ( Fig 1 ) And then slide the top cover out of the system .( Fig 2 )



Fig-1



Fig-2

### 3.2. Processor Installation

To install Socket 370 CPU, lifts up bar located next to the Socket.

And then insert Socket 370 CPU inside Socket, and push the lever bar back into original position. (Fig-3 & Fig-4 )

CPU-1

CPU-2

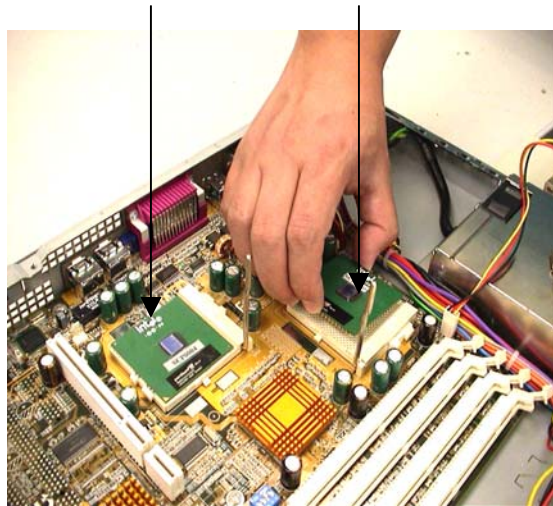

Fig-3

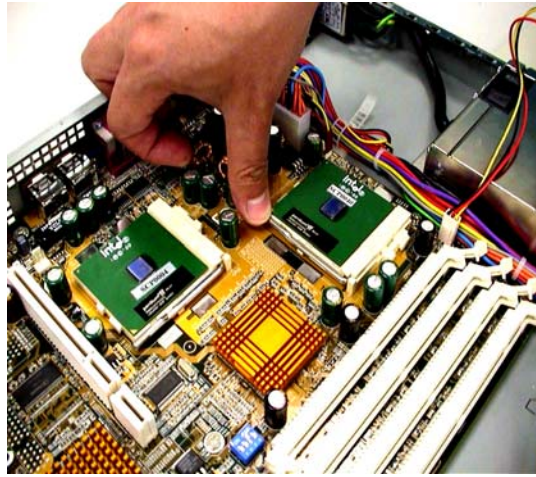

Figure 4

### 3.3. Fan+Heatsink Installation

Click Fan+Heatsink to CPU socket 370 and plug the Fan power cable to the each CPU cooling Fan connector on the motherboard . ( Fig-5 )

Make sure the Fan wire is click on the HeatSink .( Fig-6 )

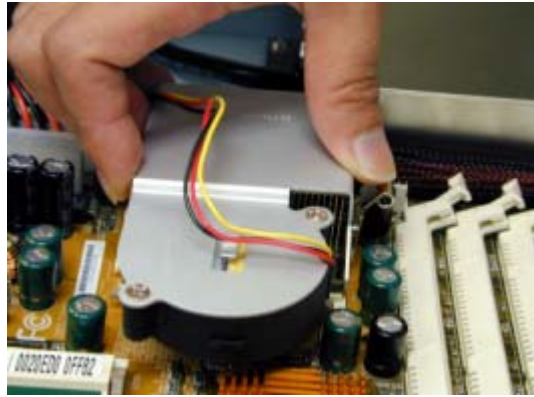

Figure 5



Figure 6

System Installation Guide

For CPU1 ,Fan power cable connect to J13 (CPU1 FAN) connector and for CPU2, Fan power cable connect to J15 (CPU2 Fan) Connector. Note to make sure the connector is plugged into the header in the correct and click well. ( Fig-7 )

J13-CPU1 Fan Connector

J15-CPU2 Fan Connector



Figure 7

### 3.4. System RAM Installation

The motherboard has 4 Dual Inline Memory Module (DIMM) sockets. The BIOS will automatically detect memory type and size. To install the memory module, just push it into the DIMM slot. (Fig-8 )

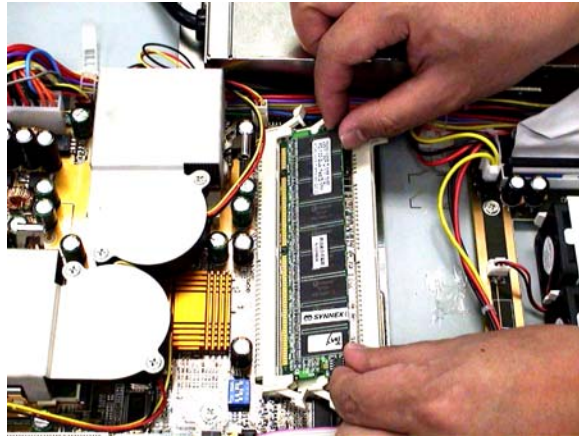

Fig-8

### 3.5. Installing Handle

Get Handle and screw from the accessories box. And then mount the handle on the front panel .( Fig-9 & Fig-10 )

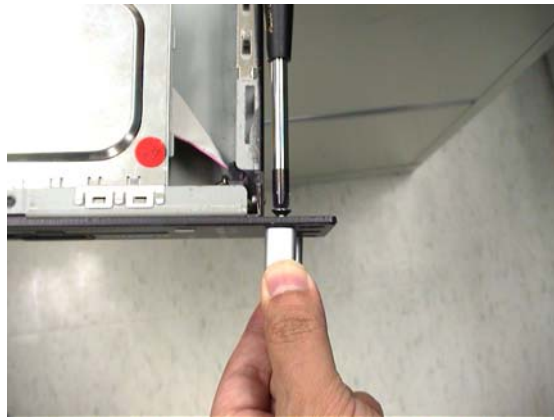

Fig-9

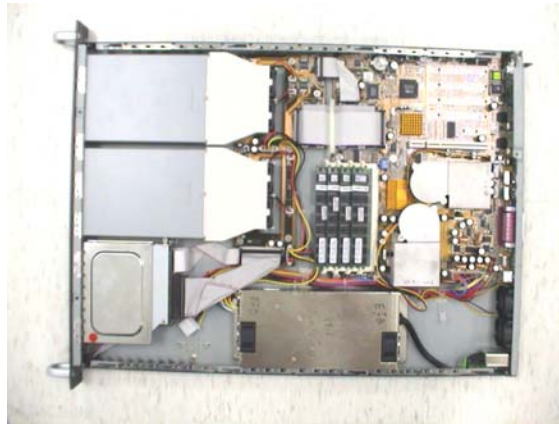

Fig-10

### 3.6. Reinstall Top Cover

After the above steps (3.1 to 3.5 ) were finished then slide a top cover to a chassis (Fig-11 )and use screwdriver to reinstall the 2 screws on the top cover .( Fig-12 )

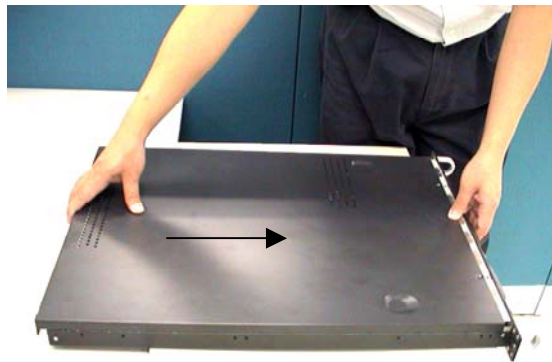

Fig-11

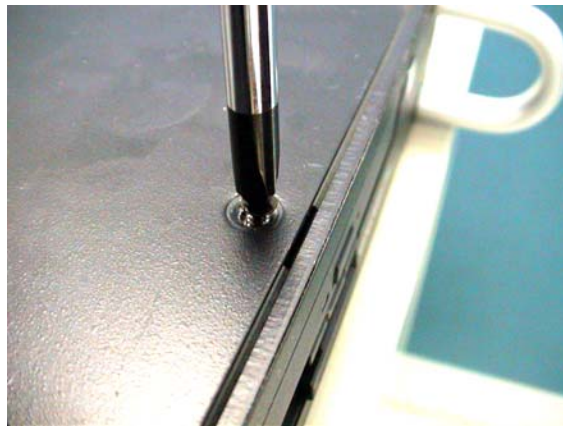

Fig-12



### 3.7. Hard Disk Drive Installation

Get the quick-swap Hard Disk tray from the accessories box. And then connect the HDD data cable and Power cable to Hard Disk Drive. Note IDE data cable Red Line is make sure to connect Hard Disk Drive pin 1. (Fig-13 & Fig-14)



Fig-13

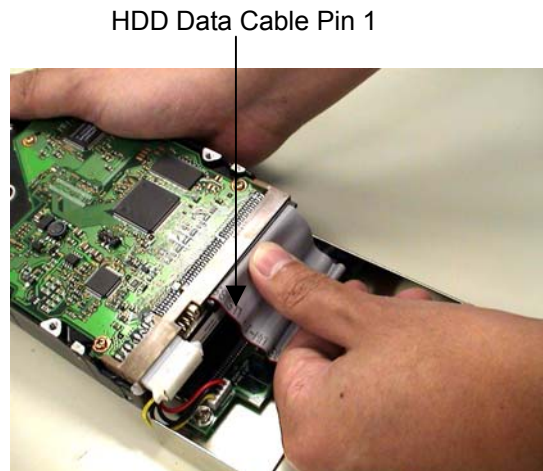

Fig-14

System Installation Guide

After the above step, mount HDD to HDD tray with the screw ( Fig-15 ),and put HDD tray into the chassis .( Fig-16 )

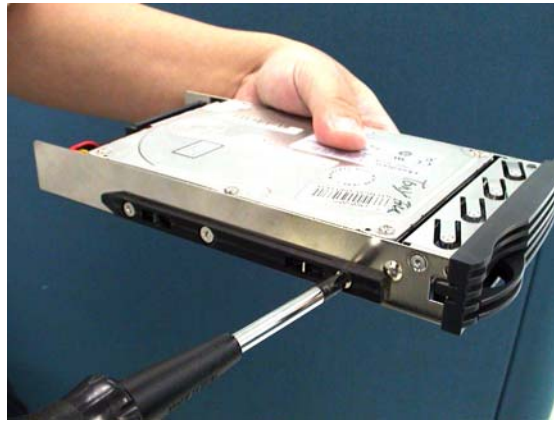

Fig-15



Fig-16

When you put HDD tray into the chassis, make sure that the lever is at a 90 degree angle to the chassis .( Fig-17 )  
Otherwise ,damage may occur to lever. After that push HDD tray to chassis carefully and make sure the HDD tray is click into Chassis. (Fig-18)

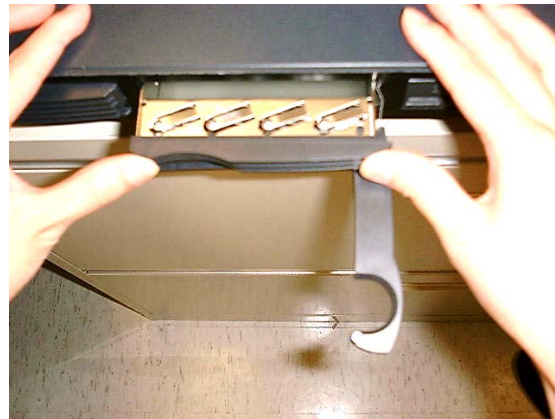

Fig-17



Fig-18

And then push lever to lock HDD tray into the chassis.  
(Fig-19)



Fig-19

If you do not making sure that the lever is at a 90-degree angle to the Chassis ,the HDD tray click may be damage .( Fig-20 )

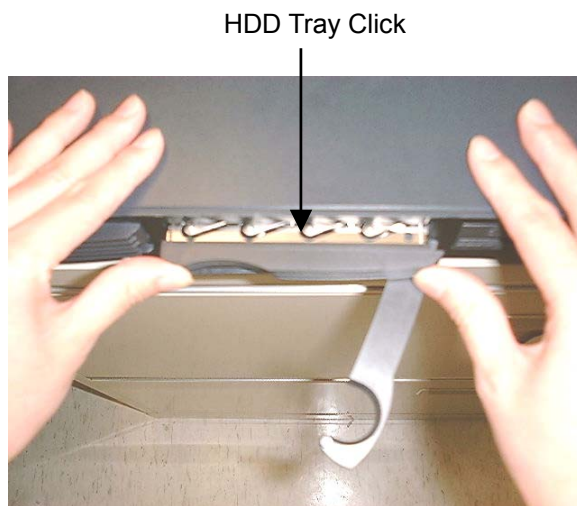

Fig-20

System Installation Guide

When you put HDD tray into the chassis ,make sure there is a no gap between HDD tray and chassis .Otherwise the system can't detect the HDD .(Fig-21 )

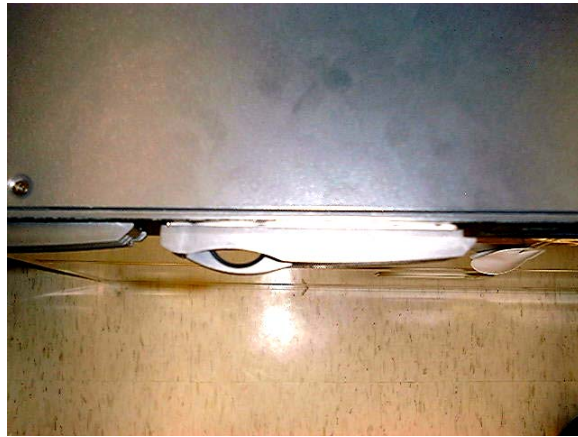
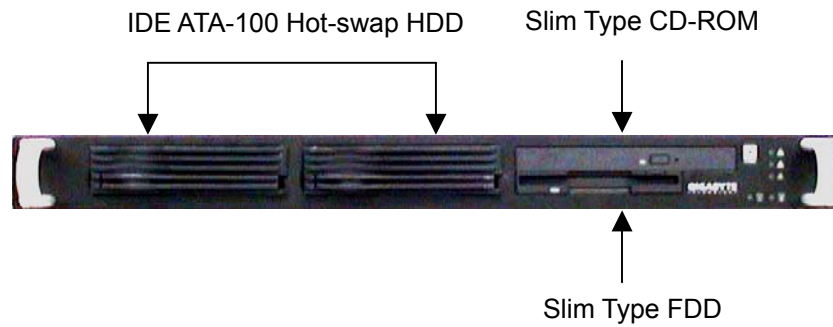
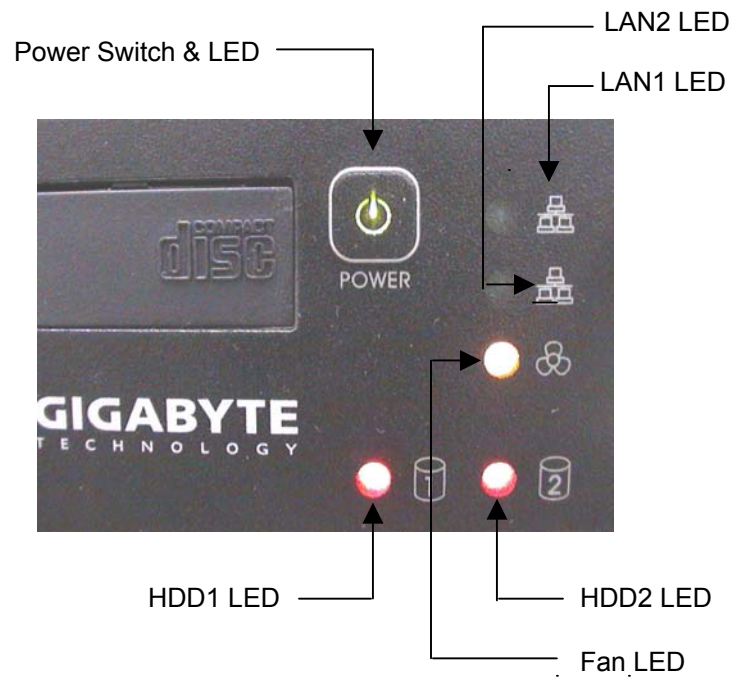

Fig-21

### 3.8. Front Side



### 3.9. LED Indicators



#### **Power LED**

Green - System Power On  
LED Off - System Power Off

**LAN LED**

Green – LAN Activity  
LED Off – No LAN Connection  
Blinking – Data Access

**Fan Led**

LED Off – System Fan Normal state  
Orange – System Fan Crash





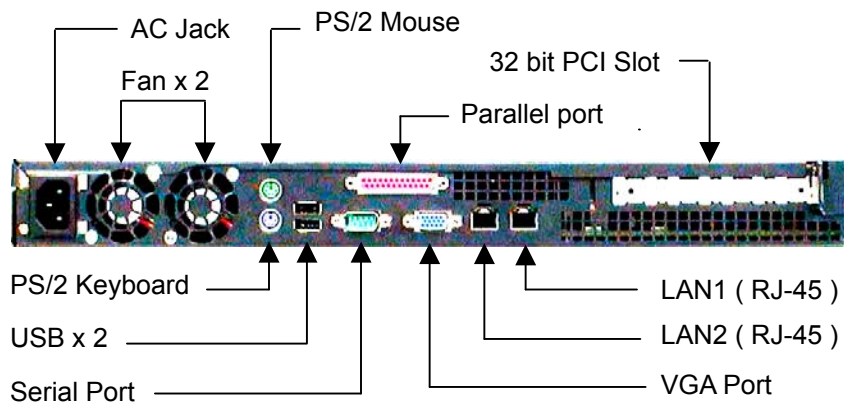

**HDD LED**

LED Off – System Booting (But when detect HDD the LED is orange)  
Green – After Booting O/S  
Green Blinking – HDD Data Access  
Orange Blinking – HDD Rebuild  
Always Red – HDD Crash

**3.10. Back Side**



### 3.11. Connector Icons

Suggested icons	Description
	Keyboard
	VGA
	Mouse
	LAN
	Parallel Port
	Serial Port
	USB